

Operations Manual

Transmitter IR29

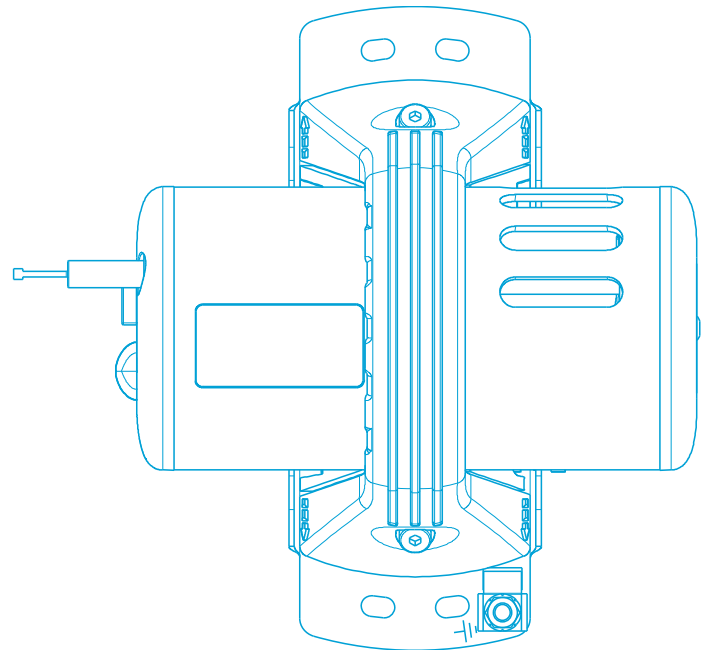
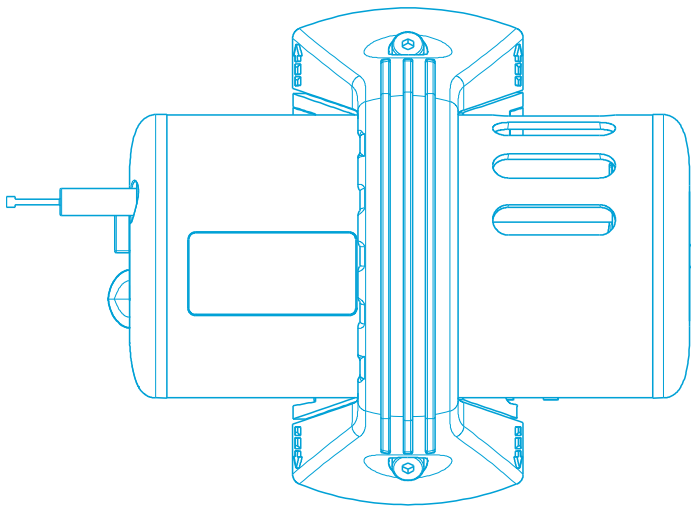

Table of contents

For Your Safety	1
Operating Instructions	1
General Description	2
Measuring Methods	2
Device Design	3
Type Plate	3
Installation Site of the Transmitter	4
Assembly	4
Installing Electrical Connections	5
Assembly and Operation with Flow Adapter	8
Using the RC2 or RC3 operator interfaces	8
Control Buttons	9
Display and LED test via RC2 or RC3 operator interfaces	9
Commissioning	9
Measuring Mode	10
Changing the Gas Measuring Channel	10
Under Range	10
Over Range	11
Display of Operating Parameters	11
Measured Value Histogram	12
Sensor Lifetime	12
Device Error	12
Zero Calibration and Adjustment (ZERO)	13
Activation	13
Execution	13
Sensitivity Calibration and Adjustment (SPAN)	15
Calibration	15
Adjustment	15
Service Menu and Advanced Service Menu	17
Activate Service Menu	17
Operation	17
Layout of the Service Menu	18
Additional Menu Explanations	19
Displays and Messages	21
Display of Special Statuses and Malfunctions	21
Error Messages of the Main CPU	23
Error Messages of the Sensor CPU	24
Displays in Measuring Mode	24
Displays in Service Mode and During Calibration (Status Messages)	25
Status of the Status LEDs and the Current Output	25
Initial Commissioning and Maintenance	26
Maintenance of Stationary Gas Warning Systems	26
Regular Functional Tests	26
Repair	27
Troubleshooting	27

Accessories	28
Connections and Terminal Assignment	29
IR29 i/Di with 4...20mA Interface and Zener barriers	29
IR29 i/Di with 4...20mA Interface and Zener barriers from MTL	29
IR29 i/Di with 4...20mA Interface and SB1	30
IR29 i/Di with 4...20mA Interface & 3-wire cable (e.g. GMA41)	31
IR29 /D with 4..20mA Interface & 3-wire cable to GMA200	32
IR29 B/DB; with RS485 Bus & Four-Wire Cable to GMA200	32
Measuring Gases and Measuring Ranges	33
Sensor Specification	33
Technical Data	35
Notes IR29	37
Appendix RC3	41
Field of Application and Intended Use	41
Operation	41
Channel Coding	41
Changing Batteries	41
Technical Data	42
Appendix SB1	43
Operating Instructions	43
Device Design	43
Install Electrical Connections	43
Technical Data	45
Declarations of Conformity, Type Examination Certificates	46

For Your Safety

This user manual states the intended use of the product according to the German Product Safety Act (ProdSG) and helps to prevent accidents and work-related injuries. It must be read and observed by all persons who operate, service, maintain and inspect this product. This product can serve its intended purpose only if it is operated, serviced, maintained and inspected according to the instructions given by GfG Gesellschaft für Gerätebau mbH. The warranty provided by the company GfG will become void if the product is not operated, serviced, maintained and inspected in accordance with GfG's instructions. The above declaration does not affect statements regarding warranties and liabilities in the company GfG's General Terms and Conditions of Sale and Delivery.

Operating Instructions

After installation but before commencing operation, gas warning systems must be inspected by an expert to ensure they operate correctly and in accordance with national standards (commissioning). In Germany, the rules of the employers' liability insurance associations must be followed, "BGR 500, chapter 2.33 section 4.4."

The transmitter has been tested for functionality prior to delivery. Calibration and alignment took place with appropriate test or calibration gases.

This however does not release you from the obligation to commission the transmitter with test or calibration gas after installation.

The IR29 transmitter is approved for use in hazardous areas and has an EC type examination certificate from DEKRA EXAM GmbH in accordance with Directive 2014/34/EU.

Certificate: BVS 09 ATEX E 135 X

For the types IR29 i and IR29 Di applies:

Marking: Ⓢ I M1 Ex ia I Ma $-25^{\circ}\text{C} \leq \text{Ta} \leq +55^{\circ}\text{C}$

Ⓢ II 1G Ex ia IIC T4 Ga $-25^{\circ}\text{C} \leq \text{Ta} \leq +55^{\circ}\text{C}$

The following applies to types IR29, IR29 D, IR29 B and IR29 DB:

Marking: Ⓢ II 2G Ex eb mb ib [ib] IIC T4 Gb $-25^{\circ}\text{C} \leq \text{Ta} \leq +55^{\circ}\text{C}$



CAUTION:

The supply voltage should under no circumstances exceed 30 V DC! This also applies to voltage peaks!

Operating Conditions:

The transmitter is only admitted to be used under atmospheric conditions, i.e. the operating parameters for temperature and pressure, according to the Technical Data in the Annex which has to be complied with.

The electrical safety is tested for the use under atmospheric conditions, i.e. up to an oxygen content of typical 21Vol%.

General Description

A fixed gas warning system consists of a transmitter and an evaluation unit (GMA, not included). The transmitter and the evaluation unit are interconnected via a shielded remote measurement cable. The transmitter converts the gas concentration into an electrical measuring signal. The evaluation of the measuring signal proportional to the existing gas concentration takes place at the evaluation unit (GMA).

The extensive electronics assumes various tasks which, on the one hand, facilitates operation and maintenance and, on the other hand, significantly enhances operational safety and measuring accuracy. The transmitter features the following:

- Measured value display on the display (optional) or on the RC2 operator panel
- Settings without opening the housing with the remote control RC 2 or RC 3
- Compensation of temperature influences
- Ex-protection in temperature range -25 to +55°C
- Functional test in the temperature range -25 to +55°C [applied for]
- Permanent status display (operation/fault) on the transmitter

Measuring Methods

The sensors built into the IR29 transmitter operate according to the infrared absorption principle. Alignment to the gas type being monitored takes place using specific optical filters combined with suitable characteristics. The reduced infrared radiation at the position of the detector is converted into an electrical signal. This signal is amplified in the IR29, filtered and used for the display or measured value transfer. Due to its design with two radiation sources, the measurement assembly offers a powerful signaling function and is less sensitive to interfering influences, such as deterioration of the radiators or temperature deviations. Soiling of the optics can also be compensated up to a certain degree. Due to the said design and additionally available temperature and pressure compensation, influence caused by ambient conditions is almost entirely eliminated.

The electronics of the transmitter IR29 converts the measuring signal into a linear measured value output 4..20 mA.

Depending on the sample gas, cross sensitivities with other gases, especially hydrocarbons, may occur.

Variants

The Transmitter IR29 - Meaning of the short description:

Designation	4..20mA Interface	RS485 Modbus	Display	Degree of Protection
IR29i	yes	no	no	Intrinsically Safe "i"
IR29Di	yes	no	yes	
IR29	yes	no	no	Increased Safety "e"
IR29D	yes	no	yes	
IR29B	no	yes	no	
IR29DB	no	yes	yes	

Device Design

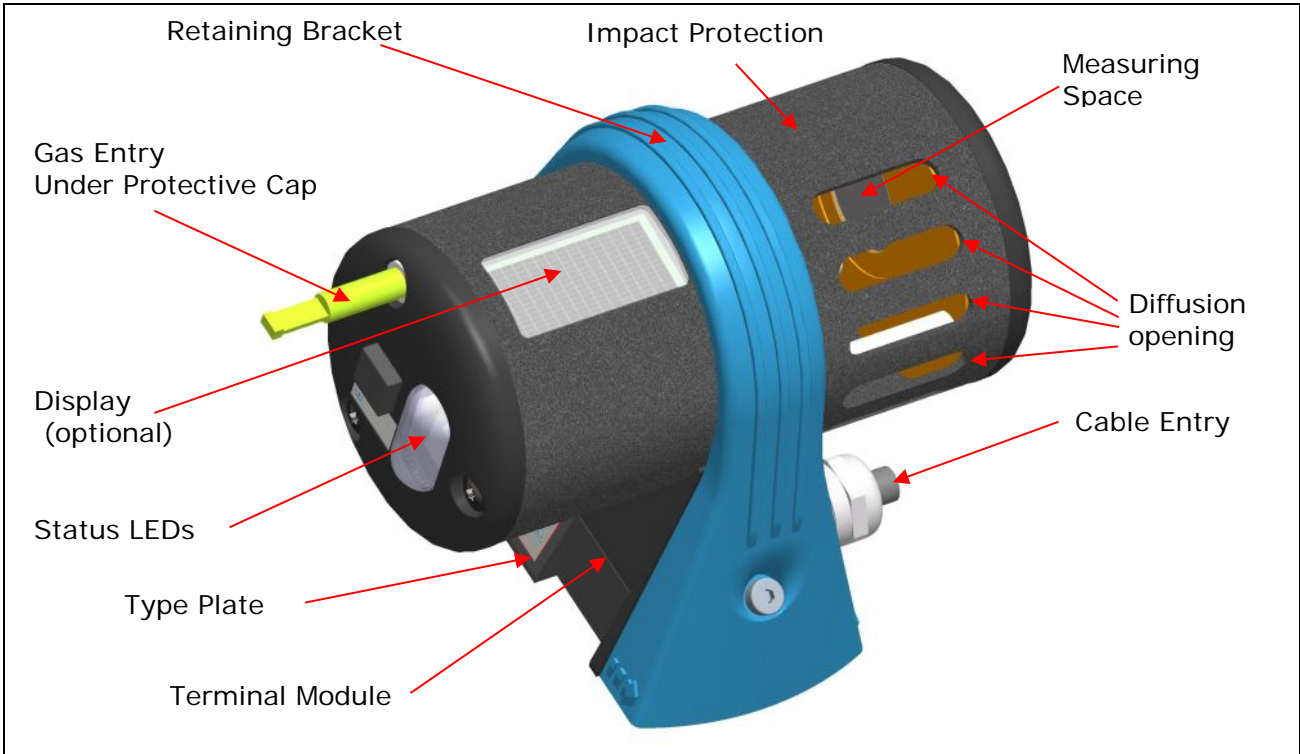

Type Plate

Transmitter version details, serial number and ATEX marking

	<p>Transmitter Type designation & serial number</p> <div style="border: 1px solid black; padding: 5px; text-align: center;"> <p>IR29 Di SN:14021930</p> </div> <p>Type Plate IR29</p> <p>GfG Gesellschaft für Gerätebau mbH - www.GfG.biz</p> <table border="1"> <tr> <td>IR29 Di</td> <td>CE</td> <td>Made in Germany</td> <td>44143 Dortmund</td> </tr> <tr> <td>QC:</td> <td>0158</td> <td>I M1 Ex ia I Ma</td> <td></td> </tr> <tr> <td>SN: 14021930</td> <td>Ex</td> <td>II 1G Ex ia IIC T4 Ga</td> <td></td> </tr> <tr> <td></td> <td></td> <td>-25°C ≤ Ta ≤ +55°C</td> <td></td> </tr> <tr> <td></td> <td></td> <td>BVS 09 ATEX E 135 X</td> <td></td> </tr> </table>	IR29 Di	CE	Made in Germany	44143 Dortmund	QC:	0158	I M1 Ex ia I Ma		SN: 14021930	Ex	II 1G Ex ia IIC T4 Ga				-25°C ≤ Ta ≤ +55°C				BVS 09 ATEX E 135 X	
IR29 Di	CE	Made in Germany	44143 Dortmund																		
QC:	0158	I M1 Ex ia I Ma																			
SN: 14021930	Ex	II 1G Ex ia IIC T4 Ga																			
		-25°C ≤ Ta ≤ +55°C																			
		BVS 09 ATEX E 135 X																			

Installation Site of the Transmitter

When determining the installation site, it is important to know the exact ambient conditions and to take them into consideration. In order to receive representative results, the ventilation conditions must be taken into account.

The position of the transmitter in the room must ensure that the gases still reach the sensor even in the event of unfavorable ventilation. If necessary, carry out a measurement, e.g. with ventilation smoke tubes.

When specifying the site of installation, it must be further observed that the transmitter can be accessed for service and calibration tasks.

External influences must also be considered, e.g.

- rainwater, splash water, dripping water, condensate
- the dust content in the atmosphere

The transmitter is protected against the ingress of water or dust to the greatest possible extent.

Special accessories can protect the transmitter against damage in extremely harsh measurement conditions. If desired, the company GfG will gladly advise you about suitable measures.



The warranty may become void if the sensor is exposed to ambient conditions which were unknown to the company GfG during the planning phase or delivery.



Transmitter types IR29, IR29 D, IR29 B and IR29 DB:

The housing only fulfils the requirements of the EN 60079-0 (table 13) in combination with the IR29 Protection cover (guard). Therefore, the IR29 Protection cover and the device need to be firmly attached.

Assembly

The assembly is carried out step by step in the following sequence:

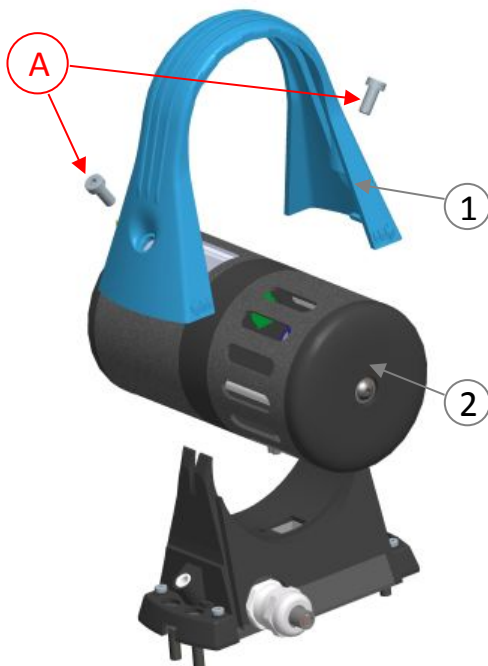

I. Loosen the screws "A" and remove the retaining bracket (1). To do so, slightly pull apart the ends of the bracket until the lugs are free.

II. Remove the transmitter (2) from the socket. Depending on the type, the electrical plug connection is either disconnected or the plug has to be unplugged manually.

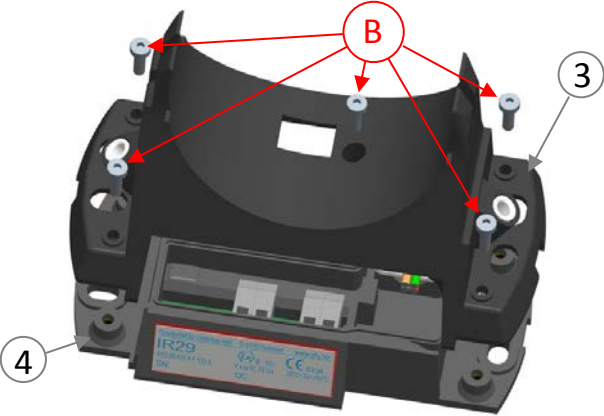
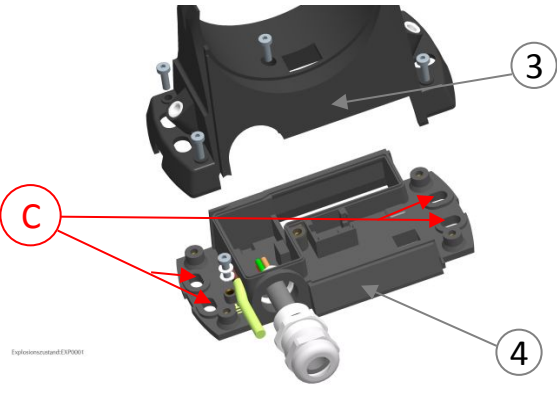
	<p>III. Loosen screws "B", remove and lift the upper part of the base (3) from the lower part (4).</p>
	<p>IV. Fasten the lower part (4) into position at the installation site; use the oval holes "C" and the screws provided for this purpose. A drilling template is supplied in the Annex to assist in the location of the holes.</p> <p>Subsequently feed the line through the cable gland (fit the shield) and install the single conductors in the terminals X1-X4 (see next chapter).</p> <p>Assemble in reverse order (steps III-I).</p>

CAUTION:
During assembly, some screws must be tightened to a defined torque. An overview can be found in the appendix.

Installing Electrical Connections

The installation of the remote measuring cables and the connection of the electrical installation may only be carried out by a specialist in compliance with the relevant regulations. The installation must be carried out with a protected cable.

For intrinsically safe devices (IR29 i/Di), e.g. Helukabel OZ-BL-CY 4X1.5 mm² or Lapp Kabel ÖLFLEX® EB CY can be used. According to the manufacturer, these exemplarily selected cables meet the requirements of DIN EN 60079-14 or IEC 60079-14 Section 12.2.2 (VDE 0165 Part 1). In addition, mechanical protection of the installed telemetry cable is required if both intrinsically safe circuits are routed in one cable. This is necessary to prevent the two intrinsically safe circuits coming into contact.

Suitable mechanical protection depends on the operating situation, the installation site and the hazard potential. The shielded PVC data cable UNITRONIC® LiYCY 3 x 1.5mm², for example, is suitable for devices with increased safety (IR29 /D/B/DB).

The conductor cross section is determined by the length of the connection line and the version of the transmitter. Remote measurement cables with a conductor cross section of 0.75 mm² can be used for short distances of up to 500 m. The conductor cross section must be 1.5 mm² for longer distances of up to 1,000 m.

The shielding is fitted in the M16x1.5 cable gland. Potential equalization may be required for the transmitter IR 29.

Only the transmitter can be installed in a potentially explosive atmosphere – the evaluation unit and the power supply unit must be installed outside this atmosphere.

If potential equalization of the housing is necessary, the potential equalization terminal can be found at the lower section of the wall holder.



The transmitter may only be installed if there is no gas present.



In possibly explosive areas all electrical lines need to be laid stationary from and to the transmitters IR29 (all types).

Each screwed and secured cable and line gland in the housing wall either has to be closed by a cable or by a plug admitted for this application.



Transmitter types IR29 i/ Di:

The user has to make sure that also in case of an error no higher voltage than $U_i = 30V$ DC may apply on the terminal of the IR29.

Transmitter types IR29, IR29 D, IR29 B and IR29 DB:

The user has to make sure that also in case of an error, no higher voltage than the maximum voltage $U_m = 45V$ DC is indicated on the type plate may apply on the terminal of the IR29.

The current interface (4..20mA) of the "i" version requires its own supply voltage. See chapter Connections and Terminal Assignment.

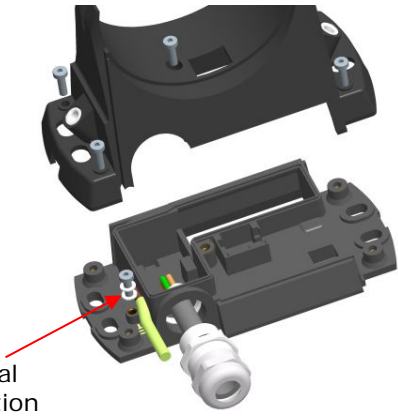
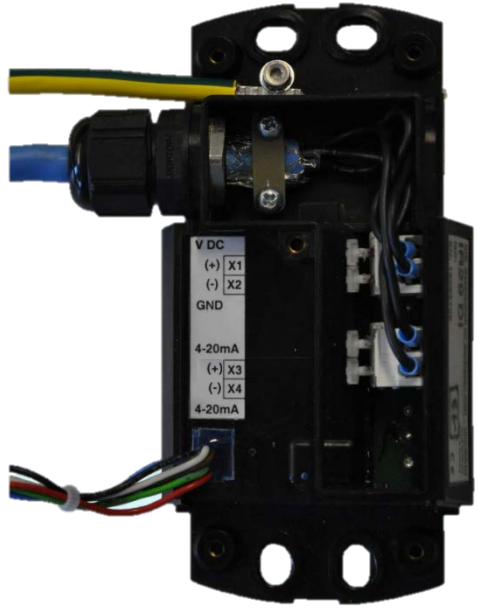
Connection Diagram IR29 i/Di	Potential Equalization
X1: 15...30V DC X2: GND X3: 15...30V (+) X4: 4...20mA (-)	 <p data-bbox="829 571 981 660">Potential Equalization 4 mm²</p> <p data-bbox="813 672 1300 705">Potential Equalization Terminal:</p> <p data-bbox="813 728 1436 795">This is located on the side next to the cable gland on the lower part of the wall holder.</p> <p data-bbox="813 806 1436 873">The potential equalization must be carried out with a cable cross-section of 4 mm².</p>
	

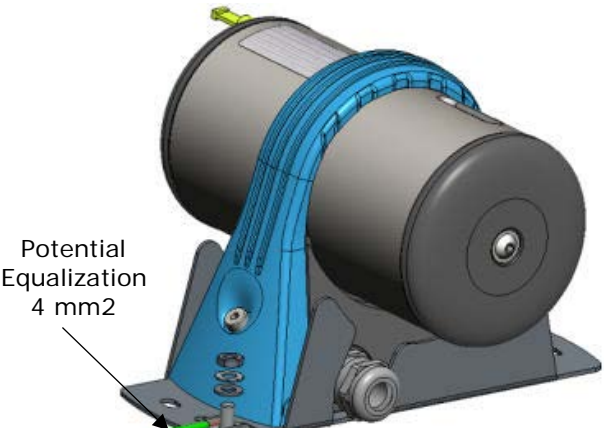
 <p data-bbox="231 1276 383 1355">Potential Equalization 4 mm²</p>	<p data-bbox="869 1097 1356 1164">Potential Equalization Terminal: (on IR29 Protection cover)</p> <p data-bbox="869 1176 1436 1310">The potential equalization terminal is positioned laterally on the guard (IR29 Protection cover) beside the cable gland (pressed in threaded bold M5x12).</p> <p data-bbox="869 1321 1436 1388">Potential equalization must take place with a line cross section of 4 mm².</p>
--	--

As shown in the diagram, the wall holder must be fixed horizontally with the cable gland facing to the left, fixed to a wall or suitable support. The impact protection should be directed downwards with the diffusion opening. For alignment, loosen the Allen screw slightly, and then turn the protection.

A different mounting of the transmitter may adversely affect the response time or the weather protection.

After the disassembly of the impact protection, a dust filter may be inserted in the measuring space. When using the dust filter, the response time of the transmitter is extended.

In the diffusion mode, the response time for methane is extended by about 50%.

This value may vary for other gases. Depending on the operation site, it is necessary to check in regular intervals if the dust filter is soiled, in order to guarantee the gas entry.

Assembly and Operation with Flow Adapter

It is possible to mount a flow adapter instead of the impact protection (Sketch see Annex). With that, it is possible to measure gas sampling in the flow via the gas supply on the IR29 and via a gas outlet on the adapter. The gas should be supplied unpressurised with a volume flow of at least 1l/min (<2l/min). A lower volume flow adversely affects the response time. The use of a flow controller may be useful in this place. The gas supply should be performed via the gas nozzle on the device; the gas outlet is performed via one of the two gas nozzles on the adapter. The two nozzles on the adapter need to be closed.

Gas supply and drain via the two connections on the adapter may adversely influence the response time. The use of the dust filter during the operation with the flow adapter may adversely influence the response time.

The connection to the gas extraction point may be performed e.g. by a PE or PTFE hose.

Delays in the response time due to the hose length need to be considered.

At an inner diameter of the line of 4mm a delay of the response time of one second per 1.3m line length at a flow of 1l/min would result. In the meantime, the pump and any possible other installations (e.g. condensate trap) additionally need to be considered.

The user has to check the sample lines by suitable measures in regular intervals in order to ensure the functionality.

Using the RC2 or RC3 operator interfaces



For service tasks, only the remote control RC 2 (BVS 04 ATEX E 212) should be connected to the transmitter, or the remote control RC 3 (BVS 08 ATEX E 006) in conjunction with an integrated display should be used at the transmitter.

The remote control RC 2 and the IR remote control RC 3 can be used in potentially explosive atmospheres.

Settings of the zero point and display sensitivity (adjustment) can be executed directly at the optionally integrated display at the transmitter IR 29 and the remote control RC 3 or with the connected remote control RC 2.

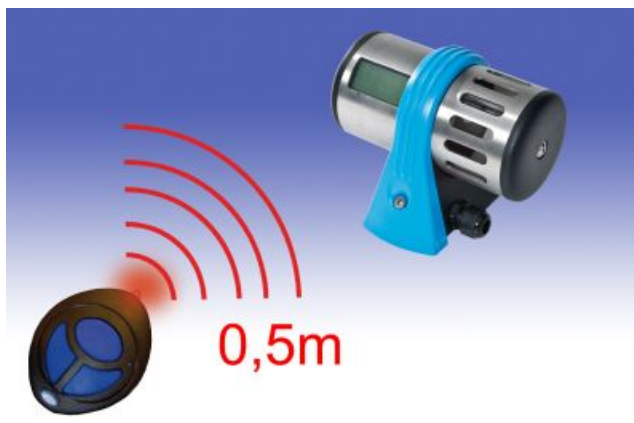

The buttons and functions of the remote control RC 2 are identical to those of the IR remote control RC 3. Output in the transmitter display takes place in plain text format; output in the remote control RC 2 display occurs in abbreviated form.

See operating instructions 206-000.13 for use of the RC2. In this manual the outputs are mostly given in the form *Display/RC2*, e.g. Code/ .

Control Buttons

The functions of the buttons at the remote control RC 2 and the IR remote control RC 3 are identical. The designation of the buttons at the RC 3 can be displayed by briefly pressing the central (oval) button at the display of the transmitter IR 29.

Additionally, there is a sketch with a key label in the appendix.

Display and LED test via RC2 or RC3 operator interfaces

In measuring mode, briefly press the  button to trigger a display and LED test. All the LEDs are subsequently activated for two seconds and all the segments of the display are shown.

Commissioning

The transmitter IR29 is tested to ensure it is functioning correctly prior to delivery. Calibration and adjustment takes place with a suitable test and calibration gas. Deviations may be identified depending on the transport, assembly and ambient conditions.

Therefore, the gas warning system must be commissioned and tested by the GfG Service to ensure it functions correctly.

After switching on, the transmitter needs, up to four minutes for:

- loading the internal buffer memory
- the self-test, during which the program and main memory are checked
- the reading and evaluation of the device parameters with simultaneous memory check
- the reading and evaluation of the sensor parameters with simultaneous memory check
- the running-in of the sensor

The memory tests occur during the first few seconds of the switch-on phase. The current interface is set to 1.2 mA, the orange and green status LEDs illuminate. During the second step, the current interface is set to 1.6 mA, the fault LED illuminates and the operation LED flashes. The following is initially shown on the display: *Einlesen Geräte-Param. (Reading device param.) / L0Pd*. The measuring unit, the type of gas, the measuring range and the calibration gas concentration are subsequently shown one after the other at the devices equipped with a display or at the remote control RC 2.

The transmitter IR29 switches to the warm-up phase of the sensor, the fault LED flashes and the operation LED indicates readiness at 5 second intervals by flashing briefly – the remaining time is shown on the display in seconds.

The measuring mode is automatically activated after the warm-up phase.

If a device error is detected during the start-up phase, the transmitter IR29 switches to error mode. The current interface is set to 1.2mA, an error message is shown on the display of the transmitter (if available) or via the remote control RC 2 (sees *Displaying special statuses and malfunctions*). The fault LED is permanently lit. The display lighting additionally flashes with display versions.

Note:

Initial commissioning demands adjustment of the zero point (*AutoCal ZERO*) after the warm-up phase and a subsequent sensitivity test, as well as possible adjustment. (*AutoCal SPAN*).

Measuring Mode

The gas concentration is measured continuously. The current interface outputs a linear proportional signal in the range 4mA to 20mA. Transfer function:

$$0 - 100 \% \text{ LEL} \propto 4 - 20 \text{ mA}$$

The current interface is updated every second.

The functions of the electronics such as the parameter memory or the sensor function are monitored continuously. During the trouble-free measuring operation, the green operating LED will flash every 15 seconds, the yellow malfunction LED is off.

For transmitters with a display, the currently measured value is being shown on the display. For transmitters without a display, the measured value is displayed on the connected operating device RC2.

The resolution of the display and the current interface depends on the gas concentration.

Gas concentration x [%UEG] (lower intervention limit)	Resolution [%UEG] (lower intervention limit)
$x \leq 20.0$	0.2
$20.0 > x \geq 50.0$	0.5
$x > 50.0$	1.0



When using an IR29 without a display, the display of the remote control RC 2 changes from gas concentration to gas unit and type of gas at one minute intervals. When using an IR29 with a graphical display, a pending measured value (>0) is shown as a bar graph, which always displays the current measured value in addition to the numerical display (the measuring gas and measuring unit are shown every 30 seconds instead of the bar graph). With display "0.0", the measuring gas and measuring unit are always displayed instead of the bar graph.

Changing the Gas Measuring Channel

For the MK244-3 it is possible to change between the measuring channels, since the measuring value can only be output via the current interface. By simultaneously pressing the buttons



and for three seconds, the active gas channel will be displayed such as:

Display:	RC2:
Choose gas channel Gas channel 1	CHA.1

Then it is possible to choose one of the two other channels by pressing the arrow buttons



and which is confirmed by pressing the central button



Under Range

Measured values below the zero point are displayed as numerical values with a negative sign. The current interface outputs a signal of between 2.8 mA and 3.9 mA according to the measured value.

If the zero point deviation is too high, the current interface is permanently set to 2.8 mA, and transmitters equipped with a display will permanently show ↓↓↓↓/_____.

Over Range

Transmitters equipped with a display, ↑↑↑↑ / ---- and the measured value are displayed alternately if the measuring range has been exceeded by up to 112.0 %. The current interface provides an output signal between 20...22 mA according to the measured value.

If the measured value exceeds 112.0 % of the measuring range, ↑↑↑↑ / ---- will flash on the display. The current interface is set to 22 mA.

Display of Operating Parameters

During measuring mode, briefly press the  button at the remote control RC 2 or RC 3 to automatically display the following important operating parameters one after the other:

- 1)
 - Measuring Gas
 - Measurement Unit
 - Measuring Range /SCAL
 - Calibration Gas Concentration /CGAS

GAS	EINHEIT
CH ₄	%UEG
MESSBEREICH	KAL.-GAS
100.0	50.0
2012-11-27 12:03.43	

- 2)
 - Average value of the last recorded 8 hours
8 h Medium/ BH
 - Average value of the last recorded 15 minutes
15 Min. Average / 0.25H

8 Std. Mittel		15 Min. Mittel	
0.0		0.0	

- 3) If an environmental sensor is installed and activated:
 - Moisture /HUM
 - Print / PrES
 - Temperature / TEMP



Feuchtigkeit	EINHEIT
41	%rF
Druck	EINHEIT
1004	mbar
Temperatur	EINHEIT
25.45	C





For transmitters without display, or if it is poorly visible / readable, the parameters can also be displayed in the 7-segment display of the remote control RC2.

For example:

UEG CH4 SCAL 100.0 CGAS 50.0 BH 0.0 0.25H 0.0 (HUM 41 rH PrES 1004 mbar TEMP 25.45 C)

Measured Value Histogram

When using a graphical display, it is possible to change to a different display mode. After triggering the display of the operating parameters via , briefly press  again to display the histogram selection.

It is possible to view data of the last 2 hours, 8 hours or 24 hours (select by pressing the  or  button, press  to acknowledge your selection). The histogram display mode subsequently appears. It is possible to display average values, maximum values and minimum values by (briefly) pressing the  or  button again.

Saved measured values are displayed in graphical form instead of the measured value display. The currently pending measured value is additionally shown in the top section together with the type of gas and gas unit. The histogram is refreshed at regular intervals and can be used as a permanent display mode.

Briefly press  or appearing special messages to exit this display mode.

Sensor Lifetime

The IR emitter used has a limited service life. If the signal level falls below 80% of the original value, the transmitter switches the measuring mode off. The error message *Sensor error -115- (unzur. signal level)/ Err_115* is shown in the display/RC2. The current interface is set to 1.2mA, the yellow fault LED lights up and the green operation LED flashes quickly.

The display of the fault message can also be an indication of contamination of the optics. The signal level at the detector may be decreased by impurities. The optics must be checked for impurities and cleaned if necessary.

To carry out the cleaning, see chapter **Initial Commissioning and Maintenance - Repair**.

If the transmitter continues to display the error message despite clean optics, the transmitter must be replaced.

Device Error

In the event of a fault in the transmitter, the yellow fault LED lights up permanently, the current interface is set to 1.2mA and an error message appears in the display (see chapter "*Displaying special states and malfunctions*").

A fault message occurs if, for example, :

- the sensor or the electronics in the transmitter are defective
- Errors occur during self-monitoring of the device

As soon as the fault has been eliminated, the yellow fault LED goes out.

Zero Calibration and Adjustment (ZERO)

The prerequisite for this inspection is atmospheric air without influencing gas contents. Synthetic air can also be used for adjustment if the atmosphere is contaminated.

The calibration adapter shown below must be used for checking or adjusting with synthetic air. The rubberised area must be tightly stretched over the diffusion openings of the impact protection. The calibration adapter can be used to feed the synthetic air without pressure at a flow rate of approx. 0.5l/min. For the complete flushing of the measuring space, a gas feed for at least 90 seconds is required.

If the zero point display deviates in measuring mode, a zero point adjustment is necessary. After changing the measuring gas (see **Service menu and Advanced Service Menu - Changing the gas type**), the zero point must also be checked and reset if necessary. The AutoCal program automatically adjusts the zero point signal under the above conditions.

Activation

The zero point can only be set via the remote control RC 2 or RC 3 (only possible with transmitter IR29 with a display).

Automatic zero point offset can only be executed after entering access code 0011 if the currently displayed value is 10 % of the maximum measuring range.

An experienced user can activate the zero point setting after entering access code 0055 with a display of up to 15 % of the maximum measuring range. This access code should only be used by fully trained staff of the operator.





If the current zero point display exceeds a value of 15 % of the maximum measuring range and it has been ensured that the display was not caused by the presence of gas, a temporary hour code (valid for max. 1 hour) can be read in the *Info / Info* submenu of the service menu (*Zero Code / Code*) and used to activate zero point setting without restrictions.

Note:

The necessity of the latter measure might be an indicator of a defective sensor and thus of the need to replace the sensor as quickly as possible.

Execution



With the RC3 and the IR29 display or the RC2 keypad, the procedure is carried out in three steps:

1. Press the  button for a longer period (at least 3 seconds) to start activation. After activation, the current interface supplies 2.0 mA throughout the entire process and the fault LED flashes at slow intervals. The following appears on the display: *Code / Code*.
2. The numerical access code 0011 or 0055 must be entered (this access code should only be used by fully trained staff of the operator). Use the  and  buttons to change the number at the current position and  to acknowledge the changes. Press the  button for a longer period to delete the last acknowledged number.
3. After the correct entry, the current measured value and the display *Zero/Zero* are alternating on the display. If the measured value remains constant during a time interval of

60 sec., the new zero point is set. The AutoCal program will be automatically terminated with the display *Save/SAVE* and changes back to the measuring mode.

Note:

If the current measured value is outside the permissible limits for the respective access code, the display *Cal. error no. 3 / ERL Err.3* briefly appears at point 3.

The AutoCal program can be shortened to a constant measured value  by pressing the key for a long time (3 sec.) while waiting. The hardware then starts directly with the zero setting. To cancel the AutoCal program without zero point adjustment during the waiting time, press the key  briefly.

The following will appear: *Abbruch(Cancel) / E5E*. Press the  button to acknowledge it.

The following error messages may occur during zero point adjustment:

Display/RC2 Display	Remark	Malfunction LED
<i>Kal.-Fehler Nr. 2</i> <i>(Cal. error no. 2) / ERL Err.2</i>	The gas signal is unstable.	fast flashing
<i>Kal.-Fehler Nr. 3</i> <i>(Cal. error no. 3) / ERL Err.3</i>	The zero point is outside the permitted tolerance range.	

All error messages must be acknowledged with . After acknowledgement with the unchanged zero point setting, the transmitter returns to measuring mode.

	
<p>Calibration adapter for IR29</p>	<p>Only for clarification: Rubberized area of the adapter via the diffusion orifices, which need to be completely covered.</p>

Sensitivity Calibration and Adjustment (SPAN)

For a device without display, the RC2 operating device is required for calibration and adjustment; for transmitters with display, it is also possible to use the remote control RC3.



Always observe special safety precautions when handling toxic gases. MAC values indicate hazards caused by toxic gases.

Calibration

First check the set calibration gas concentration by briefly pressing . The value of the calibration gas concentration should be at least 20% of the measuring range. It is possible to set 10 to 100% of the measuring range (100% LEL).

If the set value of the calibration gas concentration deviates from the available calibration gas, then the calibration gas setting in IR29 must be changed.

To do so, change to the service mode, numeric access code *1100* (or *5050* for trained staff).

Set the concentration of the available calibration gas in the sub item *cal. gas/CLAS*.

Then quit the service menu with *Save/SAVE*, in order to adopt the changes.

Use the IR29 calibration adapter shown above to calibrate or adjust the display sensitivity. The rubberised area must be tightly stretched over the diffusion openings of the impact protection. The calibration gas needs to be supplied unpressurised with a volume flow of about 0.5 l/min via the gas supply. The injection needs to be performed for 180 seconds, 90 seconds for flushing the measuring chamber, another 90 seconds for stabilizing the concentration.

It is possible to calibrate the transmitter directly on site using the RC2. If the display deviates from the calibration gas concentration, it might be necessary to adjust it (sensitivity adjustment).

Adjustment



The sensor must be free from calibration gas (zero display) prior to each re-adjustment.





Activation

An adjustment can be performed after having entered the access code *0011*.

If a measured value of $>100\%$ is displayed for the calibration, it is not possible to perform an adjustment with the code *0011*. Then, a temporary hour code (valid for max. 1 h) can be read in the *Info/Inf* submenu of the service menu (*Code/Code*). By doing this, the adjustment can be activated without restrictions, instead of the code *0011*. Then, a repeated calibration and afterwards an adjustment might be necessary, if applicable.



Implementation

With the RC3 and the IR29 with display or the RC2 control unit, the procedure is carried out in four steps:

1. Activate through pressing the button  and holding it for (min. 3 seconds). After the activation, the current interface supplies 2.0 mA throughout the entire following process and the fault LED flashes at slow intervals. The following appears on the display: *Code/Code*.
2. Then, enter the activation code *0011*. Use the  and  buttons to change the number at the current position and  to acknowledge the changes. Press the  button for a longer period to delete the last acknowledged number.
3. The display alternates between the current measured value and the display *Span/SPAN*. The instrument now waits until the concentration has risen to at least 80% of the set calibration gas. If the measured value then remains constant during a time interval of 60 seconds, the measured value is automatically used to adjust the sensitivity (display *Speichern (Save)/SAVE*). The calibration data has now been successfully updated.
4. However, the transmitter does not switch back to the measuring mode; otherwise, alarms might be triggered by a still pending concentration of calibration gas. The transmitter remains in the adjustment mode, until a decline of the gas concentration and then a stabilization of the display value will be determined. Meanwhile the display *Zero/Zero* alternating with the current measured value will be displayed. Following the stabilization, the device will switch back to the measuring mode. If no gas decline and stabilization of the measured value is being determined, the device will independently switch back to the measuring mode after three minutes.

Note:

The AutoCal program can be shortened in each phase by pressing the  button for a longer period. *Speichern (Save) / SAVE* appear briefly on the display and the measured value is accepted directly to refresh the sensitivity.

Only press the  button briefly to cancel the AutoCal program without setting the sensitivity. *Abbruch (Cancel) / ESC* appear on the display and must be acknowledged by pressing the  button. Subsequently, it is returned to measuring mode as described under 4.

The following error messages may occur during sensitivity adjustment:

Display/RC2 Display	Remark	Malfunction LED
<i>Kal.-Fehler Nr. 1</i> (<i>Cal. error no. 1</i>) / <i>ERL Err.1</i>	No increase in calibration gas has been detected.	fast flashing
<i>Kal.-Fehler Nr. 2</i> (<i>Cal. error no. 2</i>) / <i>ERL Err.2</i>	The gas signal is unstable	
<i>Kal.-Fehler Nr. 3</i> (<i>Cal. error no. 3</i>) / <i>ERL Err.3</i>	The gas signal is outside the permitted tolerance range.	

Acknowledge the error messages with . The transmitter changes to measuring mode without re-adjustment, the data of the last valid calibration is re-imported, the adjustment must be repeated.

Service Menu and Advanced Service Menu

Activate Service Menu

All-important parameters of the transmitter IR29 can be opened and changed in the service menu. The measuring mode is interrupted when opening the service menu and the device changes to service mode. The special status "Service" is indicated by the slow flashing fault LED and the output signal is set to 2.4 mA. If the user does not press any button, the device automatically exits the service mode after one minute and returns to measuring mode.



All parameter changes made in the service menu refer to the currently set gas type!







If gas type and parameters are to be changed, the new gas type must first be set before parameter changes for this gas type can take effect. Changing the gas type in the service menu - submenu Gas!

The service menu is available in two different versions.

The standard service menu is opened with access code *1100*. It is not possible to change important settings, such as measuring gas or measuring range end value, here. Such attempts are ignored and the message *Gesperrt (Locked) / FRiL* appears.

The advanced service menu is opened with access code *5050*. All settings can be carried out without restrictions in the advanced service menu. This access code should only be used by specifically trained staff of the operator.

With the RC3 and the IR29 with display or the RC2 control unit, the procedure is carried out in three steps:

1. Press the  button for at least 3 sec. The transmitter changes to service mode. The following appears on the display: *Code / CodE*.
2. Now enter the numerical access code *1100* or *5050*. Use the  and the  buttons to change the number at the current position and  to acknowledge the changes. Press the  button for a longer period to delete the last acknowledged number.
3. After correct entry, the service menu opens with menu item *Gas / GAS*. Use the  and the  buttons to select other menu items.

Operation

To select a menu item, use the  and  keys.

The activation of a desired menu item, or the selection of a parameter, takes place after the selection of .

The service menu can be exited either with or without saving the changed parameters.

Note:

Several parameters can be changed one after the other without having to store them temporarily. All the parameters previously changed in the submenus are saved when exiting the service menu via the menu item "SAVE"

Exceptions:

1) Changing the type of gas:

If a different type of gas is selected in the "Gas" menu, it is saved immediately, the parameters for this type of gas are activated and the transmitter IR29 restarts with the changed parameters.

2) Setting the date and time: These are stored directly.

Layout of the Service Menu

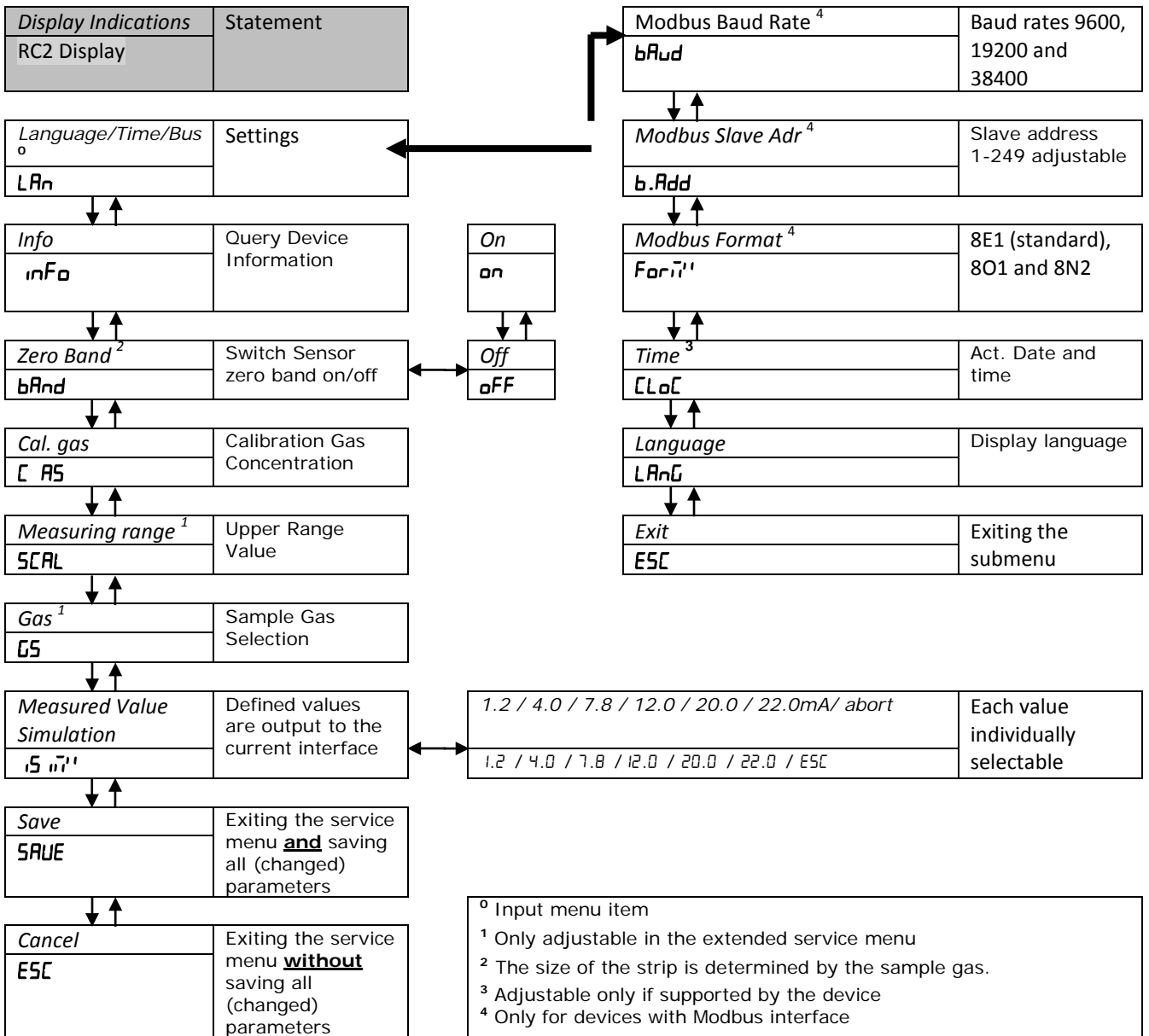

Additional Menu Explanations

Cancel

Exit the service menu without saving the parameters, changes are discarded.

Save

Exit the service menu and save all changes made to the parameters.

Measured Value Simulation

This menu item can be selected to check the functionality of the current interface without gas supply. One of 6 preset mA values (1.2/4.0/7.8/12.0/20.0/22.0) is selected with the arrow keys and confirmed with the middle button. It will be output for up to 5 minutes via the current interface, and then the transmitter changes back to the measuring mode.

The value remains active within 5 minutes, until another value (or also the same value) is being confirmed, or Cancel/ESC is being confirmed. If a value is only selected, it does not influence the current status.

Gas

With this function, it is possible to explicitly select a type of gas; the corresponding parameters are filled into the device parameter memory and are automatically loaded. Only the gases are displayed for which the data are available in the parameter memory.

Note:

If the change to another gas type is confirmed, the transmitter IR29 directly restarts.

The change to a new gas type always requires a calibration and, if necessary, an adjustment of the zero point (*AutoCal ZERO*) and subsequently a calibration of the sensitivity and, if necessary, an adjustment (*AutoCal SPAN*).

There are no restrictions for the first zero adjustment after a gas change.

After a gas change, parameters such as measuring range and calibration gas concentration must be checked and adjusted if necessary, since all changes made to the parameters under the original gas type are not accepted.

Measuring Range

The measuring range of the transmitter is fixed, e.g. 0-100% LEL.

The output range of the current interface can be set to 20.0, 25.0, 30.0, 40.0, 50.0, 75.0, 100.0% of the maximum measuring range.

Note:

The change of the output range is only an adjustment of the output signal. The standardized output signal 4...20mA is used for the set output range (Default = 100%). When reducing the measuring range, the resolution of the measuring value on the current interface is being increased. This will not change the numerical display on the display indicator/RC2.

Example: Measured value = display indicator = 25% LEL

Output range = 100% -> $I_{out} = 4mA + (16mA * 25 \%LEL / 100\% \text{ measuring range}) = 8mA$

Output range = 50% -> $I_{out} = 4mA + (16mA * 25 \%LEL / 50\% \text{ measuring range}) = 12mA$

Note: For the second setting (50%) a signal >20mA will already be output for a measuring value of 51%.

Cal.Gas

A standard value is preset in % LEL as calibration gas concentration. It must be compared and adapted to the certificate of the sample gas bottle, where applicable.

For all types of gas, the cal. gas can be set from 10% to 100% LEL.

The following instructions are applied to convert V/V to % LEL. It is rounded to one decimal place.

Gas	LEL [Vol%]	Standard CalGas
Methane CH ₄ *1	4.4	3Vol% = 68,2%LEL
Propane C ₃ H ₈ *1	1.7	1Vol% = 58,8%LEL
Acetylene C ₂ H ₂ *1	2.3	1Vol% = 43,5%LEL
Butane C ₄ H ₁₀	1.4	1Vol% = 71,4%LEL
Ethanol C ₂ H ₆ O	3,1	Calibration via cross sensitivities
n-Nonan C ₉ H ₂₀	0,7	

Zero Band

The zero band (tolerance band) of the sensor can be deactivated as required.

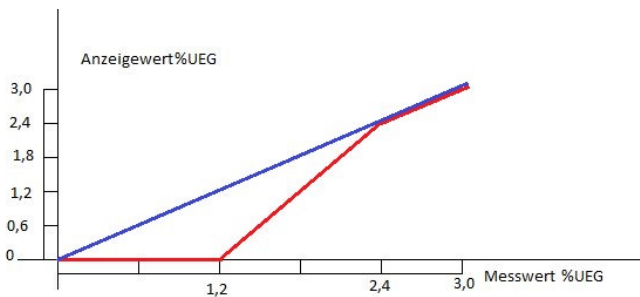

With the zero band a measuring value of ± 1.2 %LEL is being suppressed. A measuring value from 1.2 to 2.4 %LEL is mapped to the range from 0 to 2.4 %LEL, thus, an abrupt passage is being avoided.

Possible settings:

- (red) Zero band activated (*On/ON*)
- (blue) Zero band deactivated (*Off/OFF*)

Info

Retrievable/displayed device information:

- Sensor type/MK number (*Sensor type/5.tYP*)
- Serial number of the sensor (*Sensor-Nr./5.nr* Sensor).
For serial numbers higher than 9999 *5.nr- 5.nr_* is displayed on the RC2.
- Transmitter software version (*Transm.-Fw.-Ver./trRn*)
- Sensor software version (*Sensor-Fw.-Ver./5En5*)
- Current interface software version (*I₄TO₂₀-Fw.-Ver./L00P*)
- Transmitter serial number (*Fert.-Nr./F.nr- F.nr_*)
- Hour code (*Code/Code*)

Note:

The figure displayed under *Code/Code* corresponds to an access code valid limited in time, which can be activated with the zero point and sensitivity adjustment without limitations, refer to Calibration and adjustment (*SPAN & ZERO*).

Language/Time/Bus → Language

Possible language settings:

- German (*Deutsch/dEU*)
- English (*English/EnLi*)
- Spanish (*Espanol/5PA*)

Hint:

The setting of the language mainly influences on the display of the IR29. The displays of the RC2 remain unchanged, only the display LEL changes to LEL.

Language/Time/Bus → Time

Setting sequence: year, month, day, hour, minute.

Language/Time/Bus → Bus

Setting of: Modbus format, slave address, baud rate

This menu is only enabled for the IR29 B/DB. This option is not available in the i-variants, where all setting options are disabled.

Modbus format

The three options 8E1(standard), 8O1 and 8N2 are available for choice.

Modbus Slave Adresse

Modbus slave address

The address of the slave devices can be freely selected from 1 to 249.

Modbus baud rate

Three transfer speeds are available:

9600 bauds (9600 / 9.6), 19200 bauds (19200 / 19.2) and 38400 bauds (38400 / 38.4)

Displays and Messages

The following tables describe the special states in which the yellow fault LED lights up permanently and the current interface <4.0mA is set. For a better diagnosis, the transmitter IR29 without display, the error messages must be read out with the RC2 operator interface.

If the transmitter is to be restarted in the event of an error, it must be disconnected from the power supply for a short time. To do this, simply disconnect the transmitter from the socket and reconnect it after 10 seconds.

Display of Special Statuses and Malfunctions

No	Display Display RC2	Green LED	Yellow LED	Current Output	Cause	Note/Explanation [p] : permanent [Q] : Acknowledgement necessary [s] : self-resetting
001	<i>Device Test</i> tE5t	To	To	1.2mA	Program and memory tests at the beginning of system start-up	
002	<i>Reading in Device Parameters</i> L a R d	Flashing	To	1.6mA	Start up the system (when starting and after changing the type of gas).	Automatically switches to the "Display of operating parameters", and then to the sensor heat-up phase
003	<i>Sensor Warm-Up Seconds</i> Elapsing Seconds	Flashing	To	1.6mA	Sensor warm-up phase	Switches automatically to measuring mode after expiration
201	↑↑↑ "----"	To	To	22mA	The gas concentration considerably exceeded the measuring range (≥ 112,5% of the measuring range)	[s]
211	↓↓↓ "----"	To	To	2.8mA	Underrange (< -7.5% of measuring range)	[s] Zero adjustment is necessary

Note:

The error messages 211 and 201 occur when the extended measuring range (-7.5 to 112.0%LEL) is undercut/exceeded. Before, the "Displays in measuring mode" are displayed according to 210 or 203 or output via the current interface.

Error Messages of the Main CPU

No.	Display Display RC2	Green LED	Yellow LED	Current Output	Cause	Note/Explanation [p] : permanent [Q] : Acknowledgement required [s] : self-resetting
104	System error -104- (working memory defective) Err. 104	Off	To	1.2mA	Error during RAM access	[p] Restart the device. If error message appears again, replace device
105	System error -105- (program memory defective) Err. 105	Off	To	1.2mA	Error during ROM access	
106	System error -106- (param. memory defective) Err. 106	Off	To	1.2mA	Error during EEPROM access (internal)	
109	Sensor error -109- (communication error sensor CPU) Err. 109	Off	To	1.2mA	No/failed communication with sensor	[s] Restart the device. If error message appears again, replace device
110	Sensor error -110- (communication error pressure sensor) Err. 110	Off	To	1.2mA	No/failed communication with pressure sensor	
111	Sensor error -111- (communication error humidity sensor) Err. 111	Off	To	1.2mA	No/failed communication with humidity sensor	
113	System error -113- (RAM parameter) Err. 113	Off	To	1.2mA	Cyclic check of the operating parameters in the RAM miscarried	[p] Restart the device. If error message appears again, replace device
115	Sensor error -115- (unzur. signal level) Err. 115	Flashes quickly	To	1.2mA	The signal level is insufficiently low (< 80%) for an exact measurement.	[s] Check optics for soiling, otherwise Replace device
116	System error -116- (error current measurement) Err. 116	Off	To	1.2mA	Output error of the current interface or insufficient power supply	[s] Check supply voltage. Restart the device. If error message appears again, replace device
118	System error -118- (check power supply) Err. 118	Off	To	1.2mA	Supply voltage <12V, no measuring operation possible	[s] Check and readjust supply voltage
130	System error -130- (error current measurement) Err. 130	Off	To	Depending on resistance	Reading back the current from the current interface supplies actual value ≠ Setpoint	[s] Check load or line resistance in signal path

Error Messages of the Sensor CPU



No.	Display Display RC2	Green LED	Yellow LED	Current Output	Cause	Note/Explanation [p] : permanent [Q] : Acknowledgement required [s] : self-resetting
120	SenCpu error -120- (working memory defective) Err. i20	Off	To	1.2mA	Error during RAM access	[p] Reboot the system. If the error persists, replace the device.
121	SenCpu error -121- (program memory defective) Err. i21	Off	To	1.2mA	Error during ROM access	
122	ADU error -122- (Error temperature measurement) Err. i22	Off	To	1.2mA	Error A/D converter (temperature measurement/NTC)	
123	ADU error -123- ("stuck at") Err. i23	Off	To	1.2mA	A/D converter Multiplexer or AD converter defective	
124	ADU error -124- (Overrange) Err. i24	Off	To	1.2mA	A/D converter Measured value too high (upper AD converter limit)	[s] Reboot the system. If the error persists, replace the device.
125	ADU error -125- (Underrange) Err. i25	Off	To	1.2mA	A/D converter Measured value too small (lower AD converter limit)	

Displays in Measuring Mode

No.	Display Display RC2	Green LED	Yellow LED	Current Output	Cause	Note/Explanation [p] : permanent [Q] : Acknowledgement necessary [s] : self-resetting
203	Measured value change with ↑↑↑ Measured value " Change with "----" "	Flashes every 15 sec.	Off	20..22mA	The gas concentration has exceeded the measuring range (100...112.5% of the measuring range).	[s]
209	Measured value	Flashes every 15 sec.	Off	4...20mA	Trouble-free measuring operation	[s]
210	Measured value	Flashes every 15 sec.	Off	2.8...4mA	Underrange of the measuring range (-7.5...0.0% of the measuring range)	[s] Zero adjustment necessary

Note:

The states described under no. 203 and no. 210 concern an extension of the evaluation of the 4...20mA output signal to 2.8...22mA, in order to indicate deviations with consideration of tolerances in the standard measuring range.

Displays in Service Mode and During Calibration (Status Messages)						
No.	Display Display RC2	Green LED	Yellow LED	Current Output	Cause	Note/Explanation [p] : permanent [Q] : Acknowledgement required [s] : self-resetting
301	Menu Item	ON	Flashing	2.4mA	Service menu was activated via keyboard or RC2	[s] Select menu item If no entry is made for one minute, automatic return to measuring mode
302	ZERO Zero	ON	Flashing	2.0mA	AutoCal setting of zero point was activated via keyboard with RC2 or AutoZero key	[s] Automatic termination after successful adjustment
303	SPAN SPAn	ON	Flashing	2.0mA	AutoCal sensitivity setting has been activated by keyboard or RC2	[s] Automatic termination after successful adjustment
304	Cal. error (No conc. change) [RL Err.1]	ON	Flashes quickly	2.0mA	No increase in calibration gas concentration detected during AutoCal sensitivity adjustment	[Q] Acknowledge with  a) Check gas supply b) Gas feed only after calling up the adjustment
305	Cal. error (gas not stable) [RL Err.2]	ON	Flashes quickly	2.0mA	No stable zero gas or calibration gas concentration was detected during AutoCal adjustment.	[Q] Acknowledge with  a) Stabilize gas supply
306	Cal. error (Cal. not plausible) [RL Err.3]	ON	Flashes quickly	2.0mA	The zero point or the sensitivity are outside the permitted tolerance range.	[Q] Acknowledge with  Check zero or calibration gas and repeat procedure.

Status of the Status LEDs and the Current Output

For improved clarity, the following table shows the different displays of both status LEDs and the current output signals as well as their meaning for a transmitter IR29 without a display. The RC2 keypad is essential for zeroing, adjusting and calling up the service menu on a device without a display.

Green Operation LED	Yellow Fault LED	Current Output	Description see section ...
on	on	2.8mA	Displaying special states... No. 211
on	on	1.2mA	Displaying special states... No. 001
on	on	22mA	Displaying special states... No. 201
on	flashes quickly	2.0mA	Displays in service mode... Product No. 304-306
on	flashing	2.4mA	Displays in service mode... Item No. 301
on	flashing	2.0mA	Displays in service mode... No. 302, 303.
flashes every 15 sec.	from	20...22mA	Displays in measuring modeNo. 203
flashes every 15 sec.	from	4...20mA	Displays in measuring modeNo. 209
flashes every 15 sec.	from	2.8...4mA	Displays in measuring modeNo. 210
flashing	on	1.6mA	Displaying special states... No. 002, 003
flashes quickly	on	1.2mA	Displaying special states... No. 115
from	on	1.2mA	Displaying special states... No. 104-113, 116-130

Fault Messages (system and sensor faults no. 104-130, 201, 211) terminate the measuring mode until they have been eliminated. They appear permanently in the display and are additionally output via the LED code specified above (also for variants without display) and the current interface.

Status Messages are special messages that are triggered by special functions and interrupt the measuring operation. The messages 304, 305, 306 must be acknowledged, all other messages and statuses are self-resetting after a certain time. The transmitter then automatically resumes measuring operation.

Initial Commissioning and Maintenance

The DIN EN 60079-29-2 "Gas detectors – Selection, installation, use and maintenance of detectors for flammable gases and oxygen" as well as the relevant national rules and regulations must be observed. In Germany, these include "Explosion Protection Regulations", the leaflet T 023 (BGI 518) "Gas warning devices for explosion protection - use and operation" and the BGR 500, Part 2, Chapter 2.33 "Operation of systems for handling gases", 4.4 Testing of gas warning devices. During initial commissioning, gas warning devices must be checked for function by an expert after installation. (see DIN EN 60079-29-2 Section 8.9 and leaflet BGI 518 /T023 Section 8.1). Maintenance includes inspection, servicing, calibration and adjustment, as well as regular functional tests and repairs. Tests must be carried out by an expert. The result must be confirmed in writing.

According to the instruction sheet BGI 518 / T023 - "Gas warning devices for explosion protection: Application and operation", the application and operation includes the following:

- Maintenance of stationary gas warning systems
- Regular functional test

Maintenance of Stationary Gas Warning Systems

Monthly visual inspection (section 9.1 T023):

- Mechanical damage
- Contamination e.g. by dust
- Condensation due to moisture

As well as control of the:

- Protection devices of the transmitters
- Diffusion orifice of the transmitters
- Gas sampling system, gas processing (if available)

Regular Functional Tests

Tests must be carried out by an expert. The result must be confirmed in writing.

Function checks (section 9.2. T023) Interval: 4 months

Scope of functional checks:

- Calibration (measured value display) using zero and calibration gas
- Adjustment of zero point and sensitivity adjustment with zero or calibration gas
- Response Time
- Output functions (interfaces and displays)
- Error Messages

System checks (section 9.3) Interval: 1 year

It is recommended to entrust GfG customer service with these tasks.

Repair

This includes all repair and replacement work. Only use original spare parts and assemblies tested and released by the manufacturer.

If during the regular inspections of the gas warning system or by reviewing a warning or fault message a contamination of the optics of the IR29 is detected, it must be cleaned as described below:

- 1) Remove the impact protection, if necessary remove the dust filter.
- 2) Visual inspection of the sapphire disc and mirror
- 3) It is recommended to use a lint-free cloth and isopropyl in order to clean the mirror and the sapphire disk. If any other cleaning agents are used, first make sure that they are compatible with the device materials (sapphire glass, PA12, PA6 and PE).

Troubleshooting

No measuring signal at current interface:

If no measuring signal is output via the current interface, check the amount of the supply voltage and the polarity of the connections.

If the transmitter is disconnected from the base, the current interface will provide a 1.2mA fault signal if it is connected correctly. Once this state is established, the transmitter can be connected. During the warm-up time the value of the current interface should change to 1.6mA, after the warm-up time to 4mA. If this is not the case, the communication between socket and transmitter may be disturbed. An optical check of the plug connection and cleaning of the contacts with a suitable cleaner (e.g. contact WL Universal cleaner for electronics).

No display indication:

Press the "Test" button on the RC2/RC3. All pixels of the display are controlled. If the display shows no reaction or if areas of the display remain bright, the display is defective. Repairs can only be carried out by the manufacturer or the service staff.

The display is not part of the safety chain, all settings can also be performed via the RC2.

No display in RC2 and no response to key operation:

Replace the RC2 battery. If the error persists, the communication between RC2 and IR29 may be disturbed. Optical control of the connectors, test the connecting cable. If all these points are "no fault found", test the RC2 on another transmitter, if applicable.

If the same effect is being observed, the RC2 is probably defective – return the RC2 to the manufacturer. If the RC2 works with another transmitter, the error is in the IR29 – return the IR29 transmitter.

No bus communication:

- Check the bus settings in the GMA and in the transmitter (baud rate, address, bus format).
- Check the measurement loop configuration in the GMA.
- When using the GfG-GMA, check the selected connection (TRM-Bus1 or TRM-Bus2).
- Check the voltage supply of the transmitter.
- Check the polarity of the data lines on the transmitter and on the evaluation unit.
- Check if there is a cable break or a short circuit on the data line.
- Check the number and position of the terminating resistors; there may only be one terminating resistor on the last device of the bus.

Transmitter does not start / error 116, 118,130

Visual inspection of the contacts in the connector. Check if one of the pins is twisted, soiled or dented in the socket in the base (i.e. shorter than the others).

This can result in no or only poor contact between the socket and the transmitter.

If one of the pins is shortened, the only remedy will be to replace the base.

If contact is poor, clean socket and plug, e.g. with electronic cleaner or isopropanol.

Accessories	
	Best. -No.
Remote Control RC2	2800201
Connection cable for RC2 / cable length 2m	2800210
Connection cable for RC2 / cable length 5m	2800211
Connection cable for RC2 / cable length 8m	2800212
Connection cable for RC2 / cable length 10m	2800213
Remote control RC3, channel 16 (default)	2910230
Remote control RC3, channel 01-15	On Request
IR29 calibration adapter to adjust the transmitter	2910220
IR29 flow adapter to measure gas samples	2910221
Dust Filter 40mm	2900331
Dust Filter 20mm	2900332
Guard	On Request
Supply Module SB1	2910210
Spare Fuse 63mA for SB1 (F4, F5, F6)	2900381

The storage conditions for RC2, RC3 and SB1 can be found in the corresponding operating instructions or extracts from the operating instructions.

The same temperature ranges apply for the calibration adapter, flow adapter and dust filter as for the IR29 transmitter (-25°C to +60°C; recommended 0°C to +30°C).

Furthermore, the accessories need to be stored clean, dry and free from corrosive influences.

Connections and Terminal Assignment

IR29 i/Di with 4...20mA Interface and Zener barriers

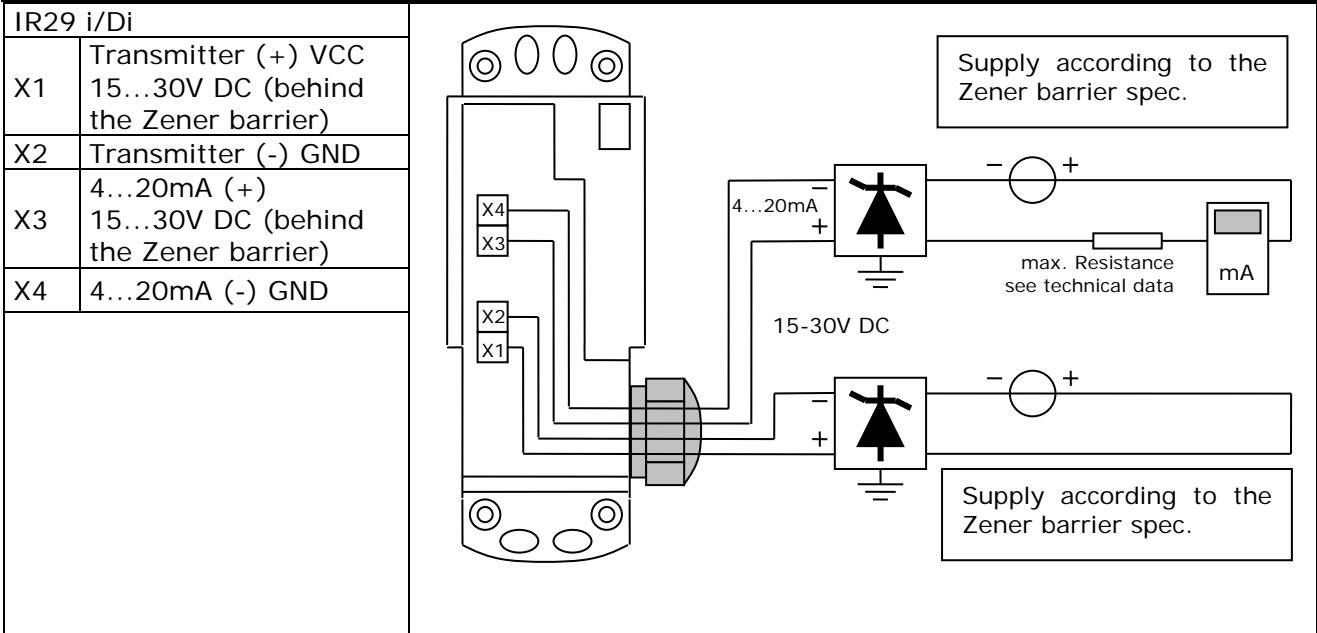

IR29 i/Di with 4...20mA Interface and Zener barriers from MTL

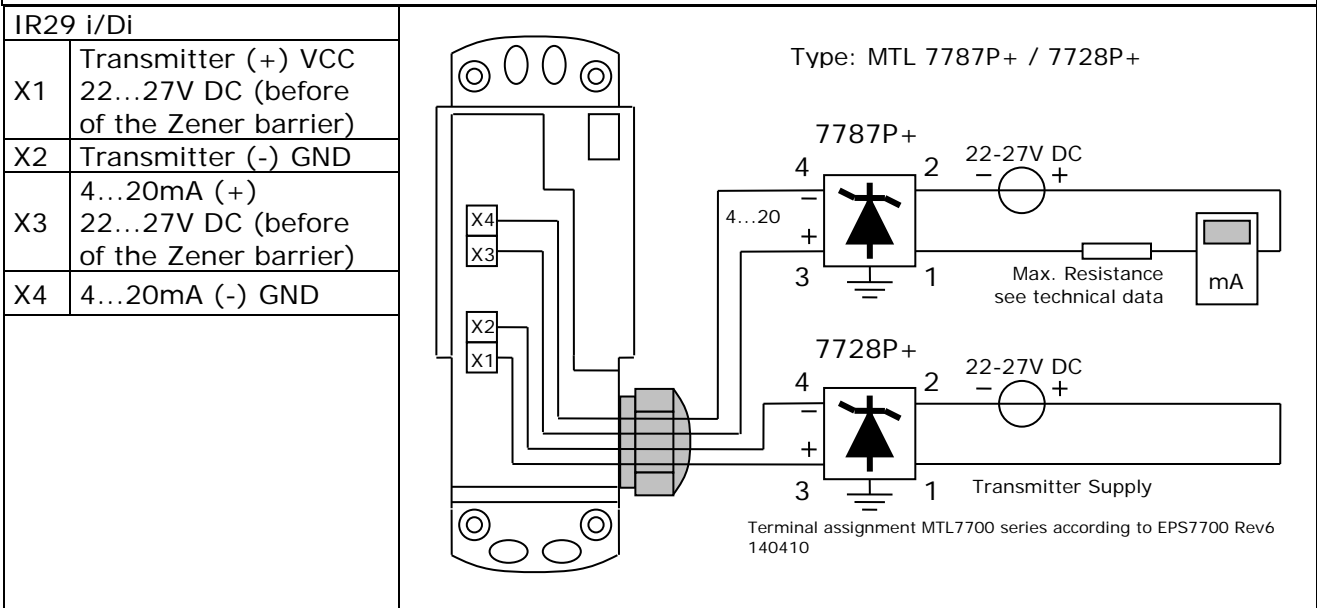

IR29 i/Di with 4...20mA Interface and SB1

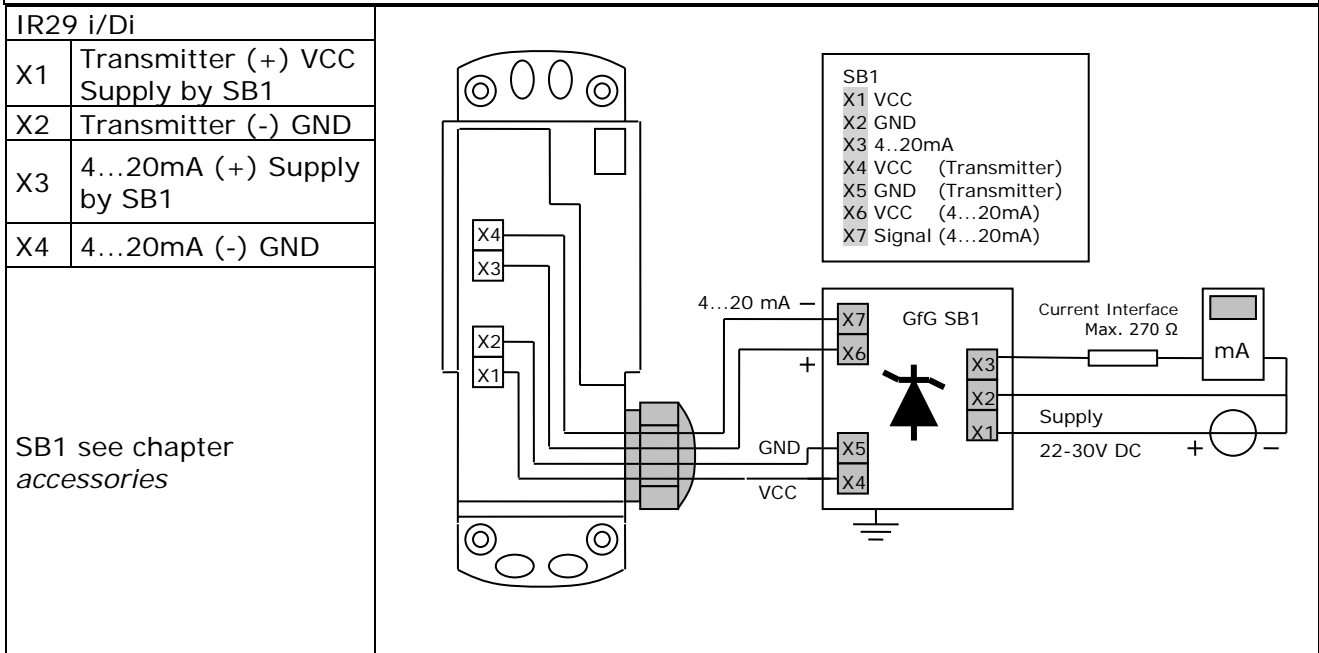

Note on installation:



The transmitter is supplied via terminals X1 and X2. The current interface is supplied via X3 and supplies the 4...20mA signal via X4. Transmitter and current interface are two galvanically separated circuits which communicate via optocouplers. If this communication is disturbed, e.g. because X1 or X2 is not connected or the transmitter is not connected to the socket (terminal), the current interface outputs 1.2 mA if voltage is already present.

IR29 i/Di with 4...20mA Interface & 3-wire cable (e.g. GMA41)

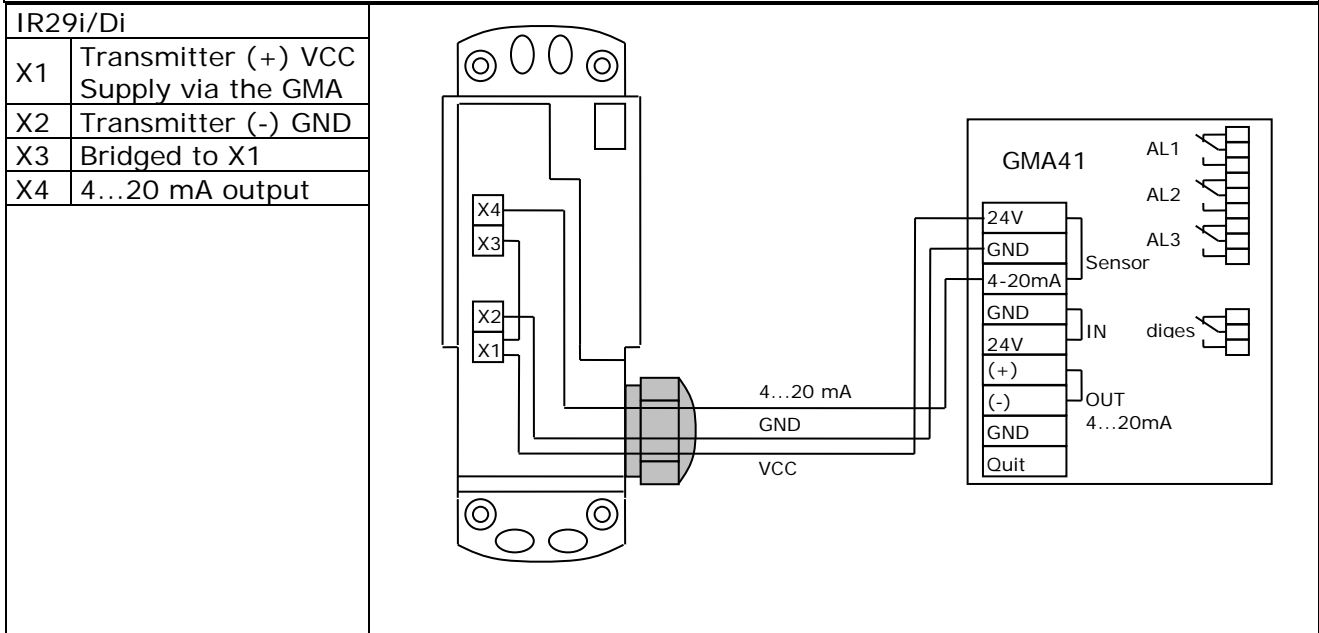

CAUTION!

To create the necessary bridge X1-X3, the wiring must be made with stranded wire. The two conductors in X1 must be professionally pressed into a common, sufficiently dimensioned ferrule.



The use of different conductors (solid wire and stranded wire) is not permitted!

The use of several solid wires in one ferrule is not permitted!

CAUTION!

This type of connection interconnects two intrinsically safe circuits. The IR29 i/Di thereby loses its intrinsic safety; operation in hazardous areas is not permitted!



IR29 /D with 4..20mA Interface & 3-wire cable to GMA200

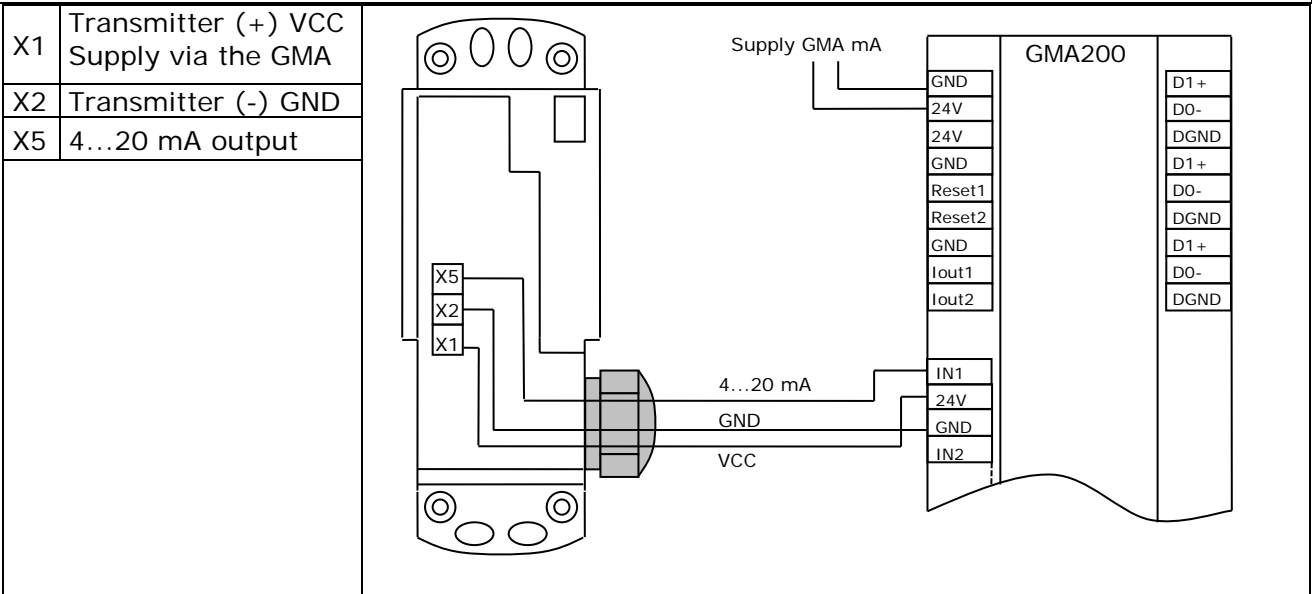

IR29 B/DB; with RS485 Bus & Four-Wire Cable to GMA200

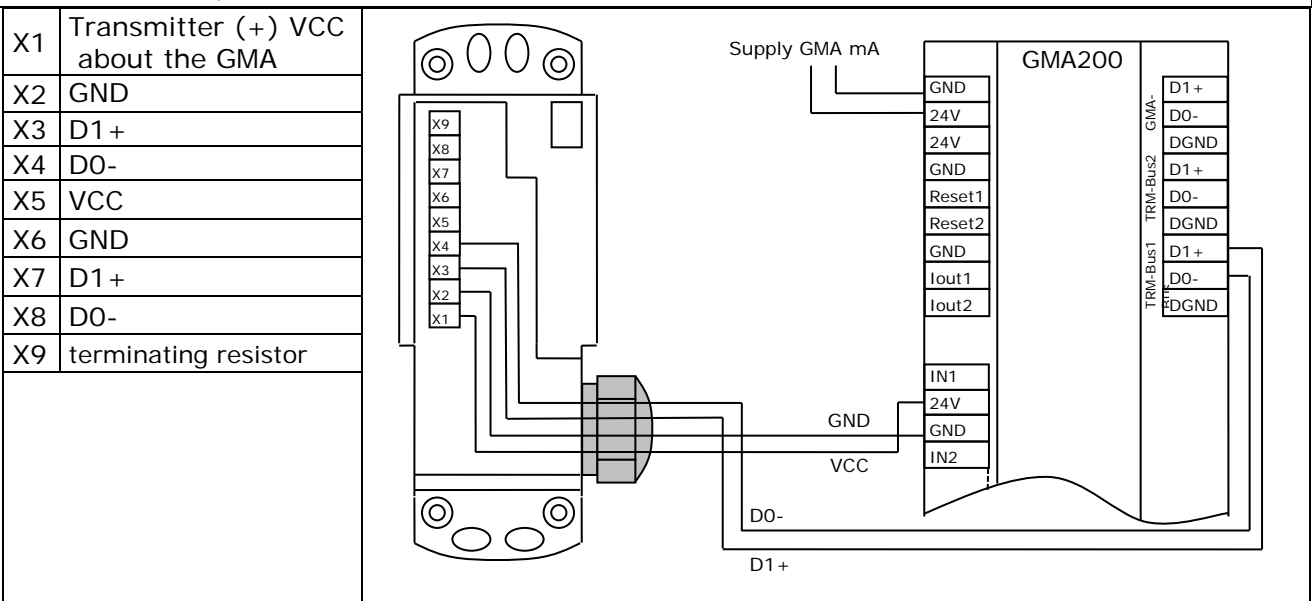

Transmitter types IR29B and IR29DB:

The non-intrinsically safe internal bus terminating resistor (120Ω) is activated by a jumper at terminals X8 and X9. Only one wire bridge may be connected. No voltage may be applied to terminal X9.

Measuring Gases and Measuring Ranges			
Measuring Gas	Measuring Range Standard	Measuring Range Smallest / Largest	MK Number
methane	0 - 100% LEL	10% UEG / 100%UEG	242-1, 244-3
propane	0 - 100% LEL	10% UEG / 100%UEG	243-1, 244-3
acetylene*	0 - 100% LEL	10% UEG / 100%UEG	244-1
Methane*, propane*, acetylene*	0 - 100% LEL	10% UEG / 100%UEG	244-3
n-butane	0 - 100% LEL	10% UEG / 100%UEG	243-1, 244-3
n-Nonan	0 - 100% LEL	10% UEG / 100%UEG	242-1, 244-3
ethanol	0 - 100% LEL	10% UEG / 100%UEG	243-1, 244-3
2-propanol	0 - 100% LEL	10% UEG / 100%UEG	243-1, 244-3

100%UEG according to DIN EN 60079-20-1: 2010

Methane CH ₄	4.4% by volume	Propane C ₃ H ₈	1.7% by volume
n-Butane C ₄ H ₁₀	1.4% by volume	Acetylene C ₂ H ₂	2.3% by volume
n-Nonan C ₉ H ₂₀	0.7% by volume	Ethanol C ₂ H ₆ O	3.1 % by volume
2-Propanol C ₃ H ₈ O	2.0% by volume		

Sensor Specification

MK242-1 Infrared sensor for flammable gases and vapors																			
Measuring Range	0.0...100%UEG																		
Disbandment	0.2..1.0%UEG																		
Tolerance Band	±1.2%UEG																		
Response Time	t50 ≤ 20sect90 ≤ 50 sec @ CH ₄ (methane)																		
Pressure750 ...1200mbar: Compensated (uncompensated)	<1.1%(1.5%) of CH ₄ indication per 1% change in pressure (regarding 100kPa)																		
Humidity0% ...95% r.h.:	max. ±2,0 %UEG or ±10% of the display (with respect to 0%r.F. @40°C)																		
Temperature-25 ...+55°C:	max. ±2,0 %UEG or ±10% of the display (regarding 20°C)																		
Cross sensitivities @ 50%UEG:	<table border="0"> <tr> <td><u>gas task</u></td> <td><u>CH₄-display0</u></td> </tr> <tr> <td>0,85Vol% C₃H₈</td> <td>ca.153%UEG</td> </tr> <tr> <td>2,20Vol% CH₄</td> <td>= 50%UEG</td> </tr> <tr> <td>1,15Vol% C₂H₂</td> <td>ca.0%UEG</td> </tr> <tr> <td>1,0Vol% C₃H₈O</td> <td>ca.89%UEG</td> </tr> <tr> <td>0,75Vol% C₄H₈O</td> <td>ca.43%UEG</td> </tr> <tr> <td>1,15Vol% C₂H₆O</td> <td>ca.105%UEG</td> </tr> <tr> <td>0,5Vol% C₆H₁₄</td> <td>ca.30%UEG</td> </tr> <tr> <td>0,7Vol% C₅H₁₂</td> <td>ca.97%UEG</td> </tr> </table> <p>They can vary from sensor to sensor and depend on the gas concentration.</p>	<u>gas task</u>	<u>CH₄-display0</u>	0,85Vol% C ₃ H ₈	ca.153%UEG	2,20Vol% CH ₄	= 50%UEG	1,15Vol% C ₂ H ₂	ca.0%UEG	1,0Vol% C ₃ H ₈ O	ca.89%UEG	0,75Vol% C ₄ H ₈ O	ca.43%UEG	1,15Vol% C ₂ H ₆ O	ca.105%UEG	0,5Vol% C ₆ H ₁₄	ca.30%UEG	0,7Vol% C ₅ H ₁₂	ca.97%UEG
<u>gas task</u>	<u>CH₄-display0</u>																		
0,85Vol% C ₃ H ₈	ca.153%UEG																		
2,20Vol% CH ₄	= 50%UEG																		
1,15Vol% C ₂ H ₂	ca.0%UEG																		
1,0Vol% C ₃ H ₈ O	ca.89%UEG																		
0,75Vol% C ₄ H ₈ O	ca.43%UEG																		
1,15Vol% C ₂ H ₆ O	ca.105%UEG																		
0,5Vol% C ₆ H ₁₄	ca.30%UEG																		
0,7Vol% C ₅ H ₁₂	ca.97%UEG																		
Expected service life	<u>6 years</u>																		

MK243-1 Infrared sensor for flammable gases and vapors															
Measuring Range	0.0...100%UEG														
Disbandment	0.2..1.0%UEG														
Tolerance Band	±1.2%UEG														
Response Time	t50 ≤ 21sect90 ≤ 50 sec @ C ₃ H ₈ (propane)														
Pressure750 ...1200mbar: Compensated (uncompensated)	<0.2%(1.2%) of C ₃ H ₈ display per 1% change in pressure, (regarding 100kPa)														
Humidity0% ...95% r.h.:	max. ±2.0 %LEL or ±10% of the display (relative to 0%R.F. @40°C)														
Temperature-25 ...+55°C:	max. ±2.0 %LEL or ±10% of the display (relative to 20°C)														
Cross sensitivities @ 50%UEG:	<table border="0"> <tr> <td><u>gas task</u></td> <td><u>C₃H₈-Anzeige</u></td> </tr> <tr> <td>0,85Vol% C₃H₈</td> <td>= 50%UEG</td> </tr> <tr> <td>2,20Vol% CH₄</td> <td>ca.17,6%UEG</td> </tr> <tr> <td>1,15Vol% C₂H₂</td> <td>ca.0%UEG</td> </tr> <tr> <td>1,55Vol% C₂H₆O</td> <td>ca.47%UEG</td> </tr> <tr> <td>0,5Vol% C₆H₁₄</td> <td>ca.19%UEG</td> </tr> <tr> <td>0,7Vol% C₅H₁₂</td> <td>ca.37%UEG</td> </tr> </table> <p>They can vary from sensor to sensor and depend on the gas concentration.</p>	<u>gas task</u>	<u>C₃H₈-Anzeige</u>	0,85Vol% C ₃ H ₈	= 50%UEG	2,20Vol% CH ₄	ca.17,6%UEG	1,15Vol% C ₂ H ₂	ca.0%UEG	1,55Vol% C ₂ H ₆ O	ca.47%UEG	0,5Vol% C ₆ H ₁₄	ca.19%UEG	0,7Vol% C ₅ H ₁₂	ca.37%UEG
<u>gas task</u>	<u>C₃H₈-Anzeige</u>														
0,85Vol% C ₃ H ₈	= 50%UEG														
2,20Vol% CH ₄	ca.17,6%UEG														
1,15Vol% C ₂ H ₂	ca.0%UEG														
1,55Vol% C ₂ H ₆ O	ca.47%UEG														
0,5Vol% C ₆ H ₁₄	ca.19%UEG														
0,7Vol% C ₅ H ₁₂	ca.37%UEG														
Expected service life	<u>6 years</u>														

MK244-1 Infrared sensor for flammable gases and vapors									
Measuring Range	0.0...100% UEG								
Disbandment	0,2..1,0% LEL								
Tolerance Band	±1.2% LEL								
Response Time	t50 ≤ 21sect90 ≤ 50 sec @ C ₂ H ₂ (acetylene)								
Pressure750...1200mbar: Compensated (uncompensated)	<0.6%(1.4%) of C ₂ H ₂ display per 1% change in pressure, (with respect to 100kPa)								
Humidity0% ...95% r.h.:	max. ±3,0 % LEL or ±10% of the display relative to 0% r.h. @40°C)								
Temperature-25...+55°C:	max. ±2.0 % LEL or ±10% of the display (regarding 20°C)								
Cross sensitivities @ 50%UEG:	<table border="0"> <tr> <td><u>gas task</u></td> <td><u>C₂H₂-Display</u></td> </tr> <tr> <td>0,85Vol% C₃H₈</td> <td>ca.0%UEG</td> </tr> <tr> <td>2,20Vol% CH₄</td> <td>ca.0%UEG</td> </tr> <tr> <td>1,15Vol% C₂H₂</td> <td><u>= 50%UEG</u></td> </tr> </table>	<u>gas task</u>	<u>C₂H₂-Display</u>	0,85Vol% C ₃ H ₈	ca.0%UEG	2,20Vol% CH ₄	ca.0%UEG	1,15Vol% C ₂ H ₂	<u>= 50%UEG</u>
<u>gas task</u>	<u>C₂H₂-Display</u>								
0,85Vol% C ₃ H ₈	ca.0%UEG								
2,20Vol% CH ₄	ca.0%UEG								
1,15Vol% C ₂ H ₂	<u>= 50%UEG</u>								
Expected service life	They can vary from sensor to sensor and depend on the gas concentration. <u>6 years</u>								

MK244-3 Infrared sensor for flammable gases and vapors																									
Measuring Range	0.0...100% UEG																								
Disbandment	0,2..1,0% LEL																								
Tolerance Band	±1.2%UEG																								
Response Time	t50 ≤ 20sect90 ≤ 50 sec @ CH ₄ (methane) t50 ≤ 26sect90 ≤ 57 sec @ C ₃ H ₈ (propane) t50 ≤ 21sect90 ≤ 50 sec @ C ₂ H ₂ (acetylene)																								
Pressure750 ...1200mbar: Compensated (uncompensated)	<1,1%(1,5%) the CH ₄ -display per 1% pressure change, (referred to 100kPa) <0,2%(1,2%) the C ₃ H ₈ - display per 1% pressure change, (referred to 100kPa) <0,6%(1,4%) the C ₂ H ₂ - display per 1% pressure change, (referred to 100kPa)																								
Humidity0% ...95% r.h.:	max. ±3,0 %UEG or ±10% of the display relative to 0% r.h. @40°C)																								
Temperature-25...+55°C:	max. ±2,0 %UEG or ±10% of the display (regarding 20°C)																								
Cross sensitivities @ 50%UEG:	<table border="0"> <tr> <td><u>gas task</u></td> <td><u>CH₄-Display</u></td> <td><u>C₃H₈-Display</u></td> <td><u>C₂H₂-Display</u></td> </tr> <tr> <td>0,85Vol% C₃H₈</td> <td>ca.153%UEG</td> <td><u>= 50%UEG</u></td> <td>ca.0%UEG</td> </tr> <tr> <td>2,20Vol% CH₄</td> <td><u>= 50%UEG</u></td> <td>ca.17,6%UEG</td> <td>ca.0%UEG</td> </tr> <tr> <td>1,15Vol% C₂H₂</td> <td>ca.0%UEG</td> <td>ca.0%UEG</td> <td><u>= 50%UEG</u></td> </tr> <tr> <td>0,5Vol% C₆H₁₄</td> <td>ca.30%UEG</td> <td>ca.19%UEG</td> <td>ca.0%UEG</td> </tr> <tr> <td>0,7Vol% C₅H₁₂</td> <td>ca.97%UEG</td> <td>ca.37%UEG</td> <td>ca.0%UEG</td> </tr> </table>	<u>gas task</u>	<u>CH₄-Display</u>	<u>C₃H₈-Display</u>	<u>C₂H₂-Display</u>	0,85Vol% C ₃ H ₈	ca.153%UEG	<u>= 50%UEG</u>	ca.0%UEG	2,20Vol% CH ₄	<u>= 50%UEG</u>	ca.17,6%UEG	ca.0%UEG	1,15Vol% C ₂ H ₂	ca.0%UEG	ca.0%UEG	<u>= 50%UEG</u>	0,5Vol% C ₆ H ₁₄	ca.30%UEG	ca.19%UEG	ca.0%UEG	0,7Vol% C ₅ H ₁₂	ca.97%UEG	ca.37%UEG	ca.0%UEG
<u>gas task</u>	<u>CH₄-Display</u>	<u>C₃H₈-Display</u>	<u>C₂H₂-Display</u>																						
0,85Vol% C ₃ H ₈	ca.153%UEG	<u>= 50%UEG</u>	ca.0%UEG																						
2,20Vol% CH ₄	<u>= 50%UEG</u>	ca.17,6%UEG	ca.0%UEG																						
1,15Vol% C ₂ H ₂	ca.0%UEG	ca.0%UEG	<u>= 50%UEG</u>																						
0,5Vol% C ₆ H ₁₄	ca.30%UEG	ca.19%UEG	ca.0%UEG																						
0,7Vol% C ₅ H ₁₂	ca.97%UEG	ca.37%UEG	ca.0%UEG																						
Expected service life	They can vary from sensor to sensor and depend on the gas concentration. <u>6 years</u>																								

MK247-1 Infrared sensor for CO₂									
Measuring Range	0,00...10,00 Vol%								
Disbandment	0.01..0.1 vol%								
Tolerance Band	-								
Response Time	t50 ≤ 30sect90 ≤ 130 sec @ CO ₂ (carbon dioxide)								
Pressure:	750...1200mbar:								
Humidity:	0%...95% r.h.								
Temperature:	-25...+55°C								
Cross sensitivities @ 50%UEG:	<table border="0"> <tr> <td><u>Gas task</u></td> <td><u>CO₂-Display</u></td> </tr> <tr> <td>0,85Vol% C₃H₈</td> <td>ca.0Vol%</td> </tr> <tr> <td>2,20Vol% CH₄</td> <td>ca.0Vol%</td> </tr> <tr> <td>1,15Vol% C₂H₂</td> <td>ca.0Vol%</td> </tr> </table>	<u>Gas task</u>	<u>CO₂-Display</u>	0,85Vol% C ₃ H ₈	ca.0Vol%	2,20Vol% CH ₄	ca.0Vol%	1,15Vol% C ₂ H ₂	ca.0Vol%
<u>Gas task</u>	<u>CO₂-Display</u>								
0,85Vol% C ₃ H ₈	ca.0Vol%								
2,20Vol% CH ₄	ca.0Vol%								
1,15Vol% C ₂ H ₂	ca.0Vol%								
Expected service life	They can vary from sensor to sensor and depend on the gas concentration. <u>6 years</u>								

Technical Data

Device Types	IR29i and IR29Di
Measurement Function	Measuring principle: infrared absorption Output signal: 4...20mA (max.load without Zener barrier :500Ω @18V or 800Ω @≥24V) (max. load with Zener barrier: 450Ω @22V or 550Ω @≥24V) (max. load with GfG SB1: 600Ω @22V - 30V)
Power Supply	Supply voltage: 18...30V DC @supply intrinsically safe 22...27V DC @supply via Zener barrier (RL* max = 250 Ω) 22...30V DC @supply via GfG transmitter supply module SB1 Maximum supply current: < 50mA
Climatic Conditions	Temperature (storage): -25...+60°C or 0...+30°C (recommended) Temperature (operation): -25...+55°C (see also sensor specification) Air pressure: 750.. 1200mbar (see also sensor specification) Humidity: 0..100% r.h. (non-condensing) Oxygen content of the atmosphere: ≤ 21.0% by volume
Case	Dimensions: (132.5 - 152.5) x 75mm (L x Ø) ** Mounting surface min. 161mm x 133mm; height 118mm Weight: approx. 950 grams Housing material: stainless steel, polycarbonate, PA12, POM Housing protection class: IR29i / Tue: IP 67 IR29Di with rotatable display: IP 40
Approvals and Tests	Marking and type of protection: CE 0158 Ⓢ I M1 Ex ia I Ma -25°C≤Ta≤+55°C Ⓢ II 1 G Ex ia IIC T4 Ga -25°C≤Ta≤+55°C EC type-examination certificate: BVS 09 ATEX E 135 X Electrical parameters for intrinsically safe connection Intrinsically safe supply circuit: Connection via terminals X1 and X2 Maximum input voltage: Ui DC 30V Maximum internal capacity: Ci 11nF Maximum internal inductance: Li negligible Intrinsically safe signal circuit: Connection via terminals X3 and X4 Maximum input voltage: Ui DC 30V Maximum internal capacity: Ci 1.8nF Maximum internal inductance: Li negligible The intrinsically safe signal circuit is safely galvanically isolated from the intrinsically safe supply circuit up to a sum of the peak values of the nominal voltages of 60V.

*) series resistance of the GfG transmitter supply module or the Zener barrier

**) Length depending on sensor configuration; without sealing plug

Device Types	IR29, IR29 D, IR29 B and IR29 DB
Measurement Function	Measuring principle: infrared absorption Output signal for IR29 and IR29D: 4...20mA (max.load without Zener barrier :500Ω @18V or 800Ω @≥24V) for IR29B and IR29DB RS485 two-wire interface
Power Supply	Supply voltage: Maximum voltage: 45V DC Supply voltage: 18V DC ... 30V DC Maximum supply current: 70mA Signal circuit (4-20mA) 30V DC Rated voltage Signal circuit (RS485) 20V DC Rated voltage
Climatic Conditions	Temperature (storage): -25...+60°C or 0...+30°C (recommended) Temperature (operation): -25...+55°C (see also sensor specification) Air pressure: 750..1200mbar (see also sensor specification) Humidity: 0..100% r.h. (non-condensing) Oxygen content of the atmosphere: ≤ 21.0% by volume
Case	Dimensions: (132.5 - 152.5) x 75mm (L x Ø) ** Mounting surface min. 161mm x 174mm; height 118mm Weight: approx. 1100 gram Housing material: stainless steel, polycarbonate, PA12, POM Housing protection class: IR29 / D/ B/ DB: IP 67 IR29 D/ DB with rotatable display: IP 40
Approvals and Tests	Marking and type of protection: CE 0158  II 2G Ex eb mb ib [ib] IIC T4 Gb -25°C≤Ta≤+55°C EC type-examination certificate: BVS 09 ATEX E 135 X

**) Length depending on sensor configuration; without sealing plug

GfG Gesellschaft für Gerätebau mbH Klönnestraße 99 - D-44143 Dortmund Telephone: +49 (0)231 - 564 00-0 Fax: +49 (0)231 - 564 00-895 Web: www.gasmessung.de Email: info@gfg-mbh.com Firmware Version 1.20	
224-000.20_BA_IR29.do	Last updated: 09 July 2018 Subject to change

Mounting accessories

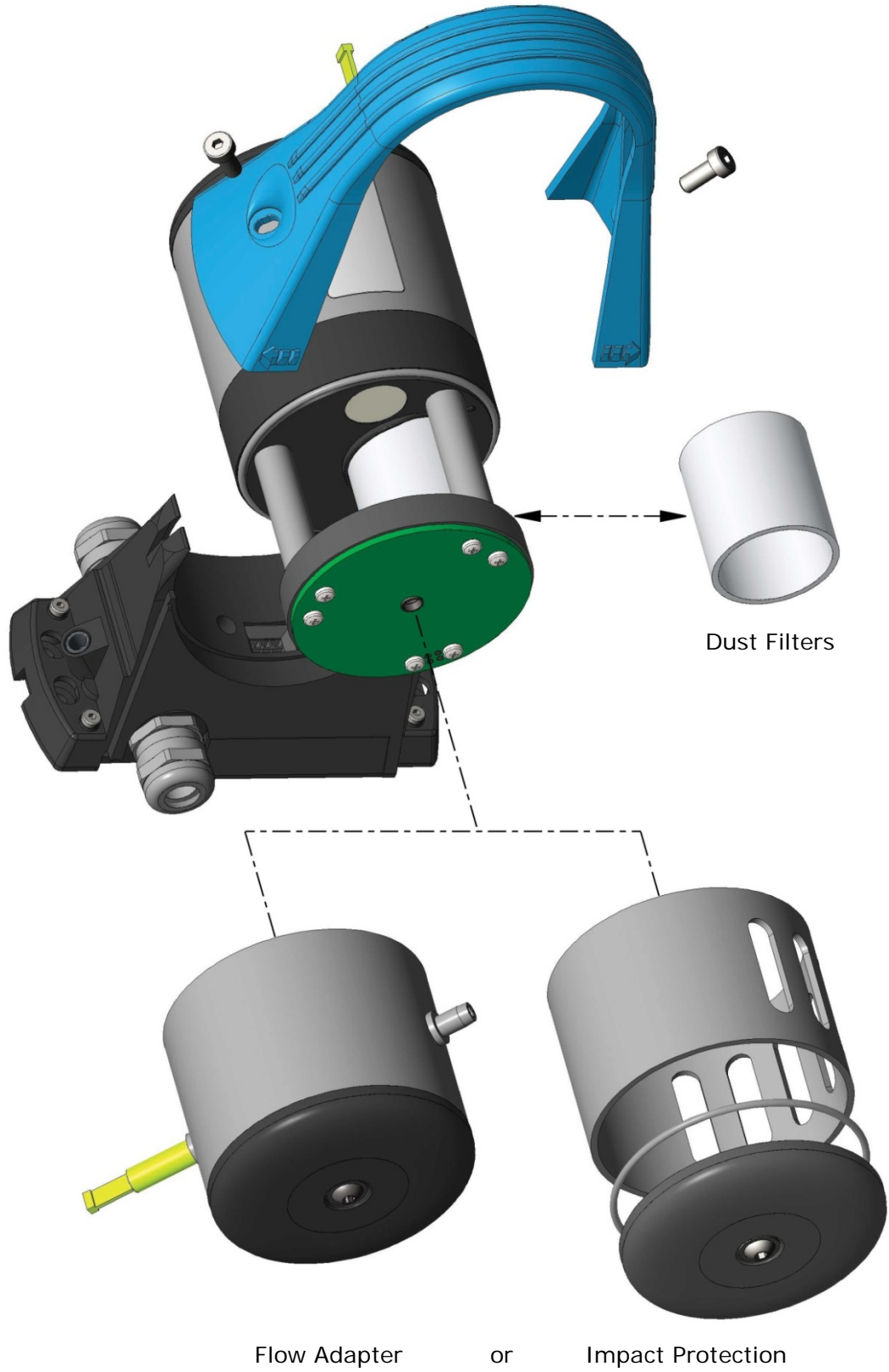

Overview Torques

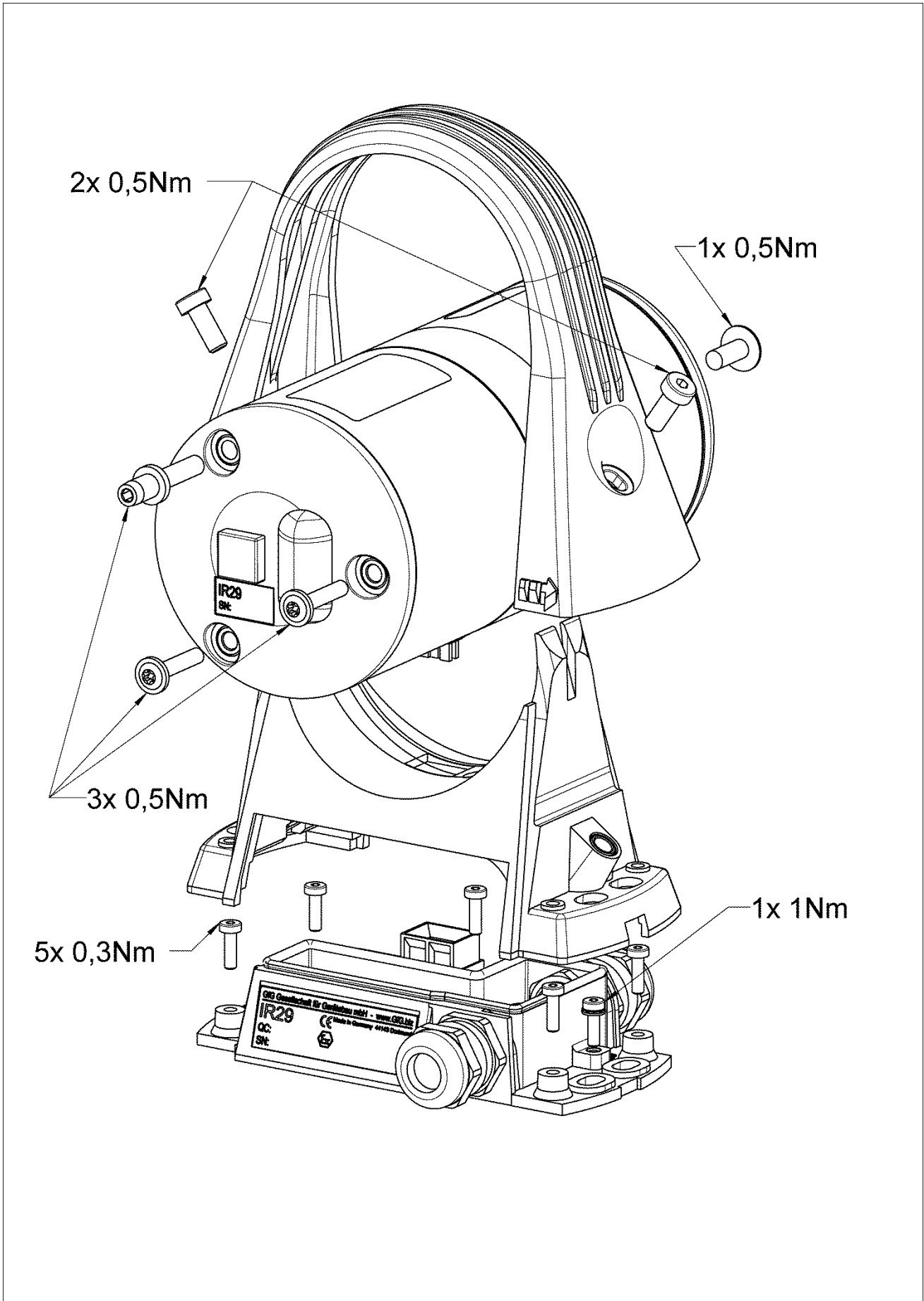

Auf Maßhaltigkeit prüfen, ggf. Druckeinstellungen anpassen!

Bohrschablone (M1:1)

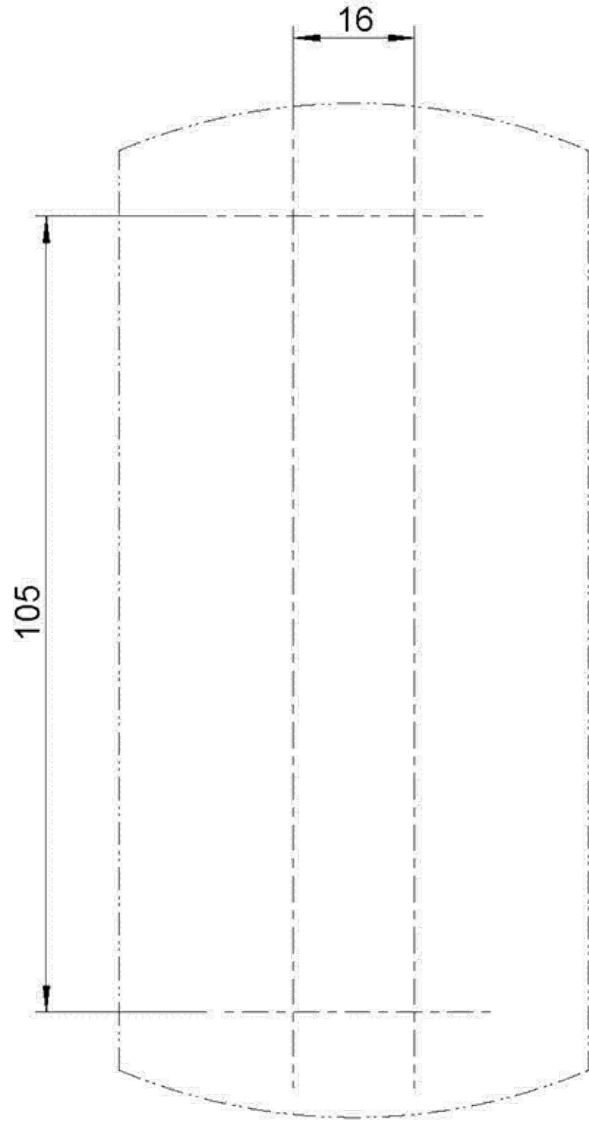

IR29 ohne Schutzblech

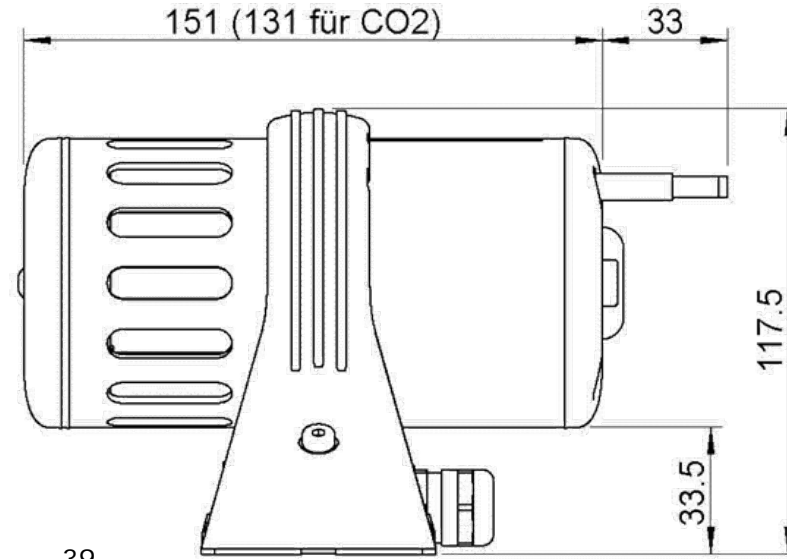
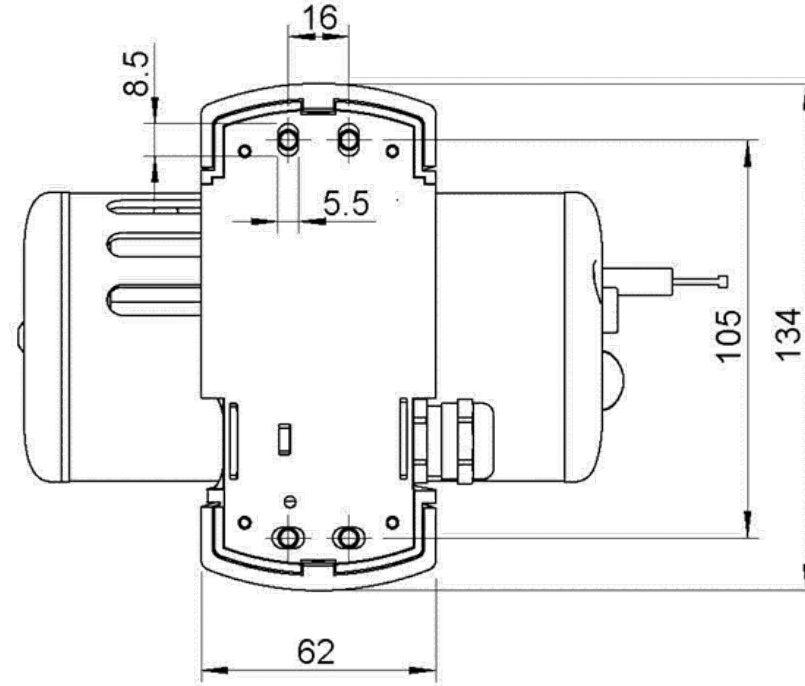

Auf Maßhaltigkeit prüfen, ggf. Druckeinstellungen anpassen!

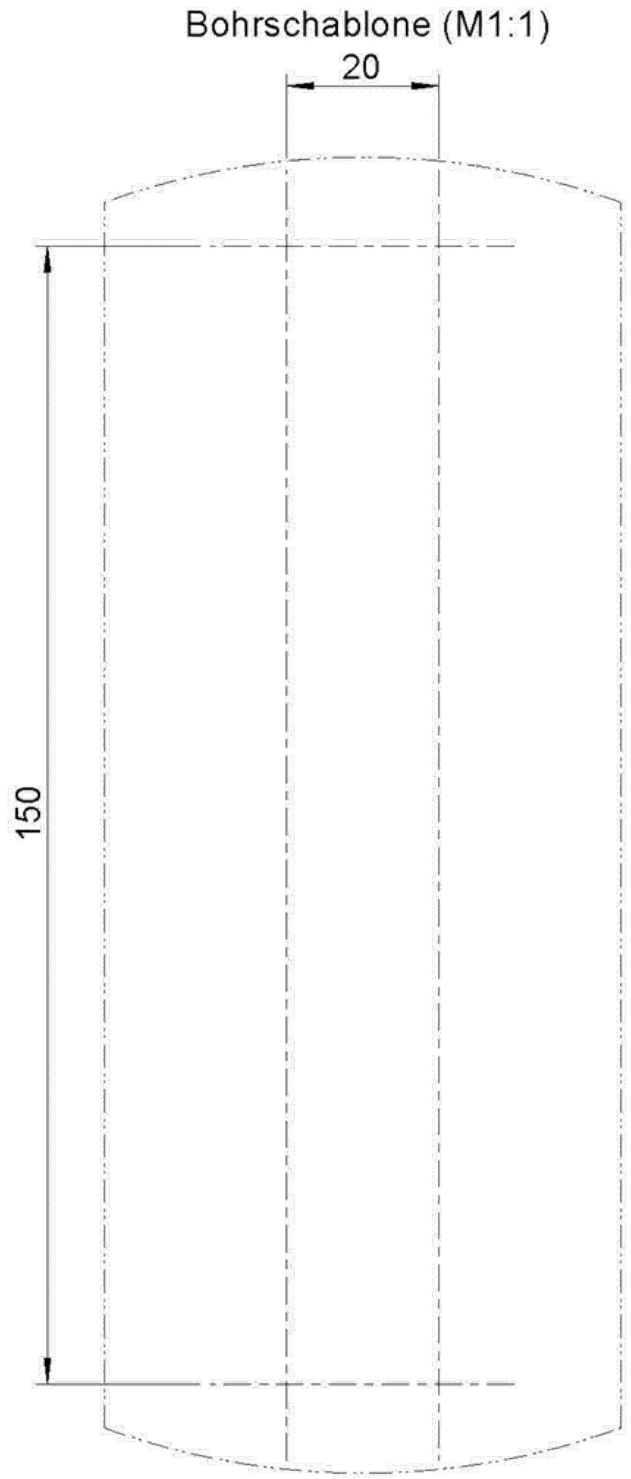

IR29 mit Schutzblech

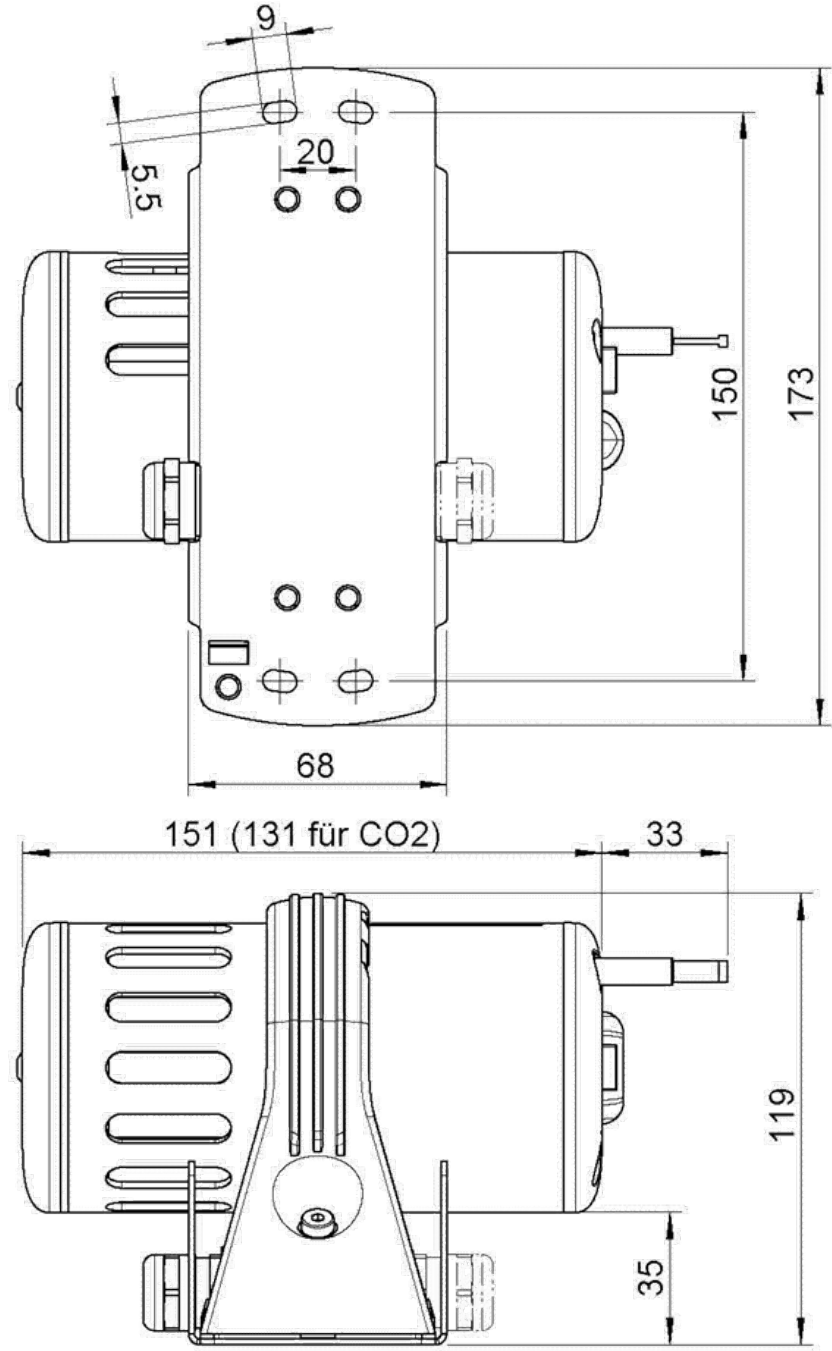

Appendix RC3

Field of Application and Intended Use

The RC3 control unit can only be used to operate the IR29 transmitters with display. The RC3 operator interface is powered by a lithium battery, which must not be replaced in hazardous areas.

The RC3 operator interface is approved for use in potentially explosive atmospheres and has an EC type-examination certificate issued by DEKRA EXAM GmbH in accordance with Directive 94/9/EC (ATEX100a) with the following

Certificate: BVS 08 ATEX E 006

Certification: Ⓢ I M1 Ex ia I Ma

Ⓢ II 1G Ex ia IIC T6 Ga -20°C≤Ta≤+55°C

Operation

The button assignment of the RC 3 can be shown on the display of the device by briefly pressing the central button.

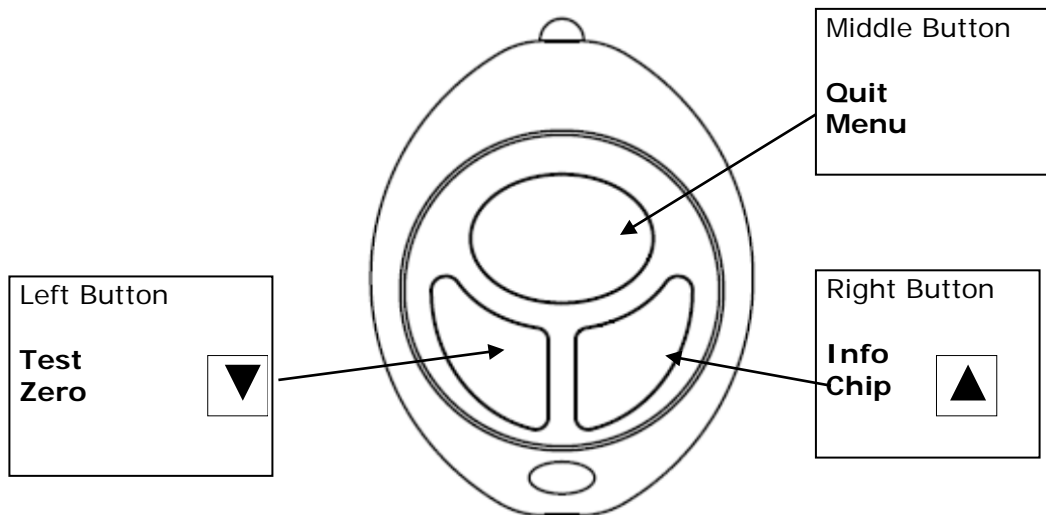

The receiver software only responds to activations >0.6 sec. to avoid unintentional or incorrect operation.

Channel Coding

The RC3 is factory coded on channel 16. This allows any IR29 transmitter to be operated. Channels 1-15 can be factory coded in RC3 and transmitted on request. In this way it is possible to group devices that can only be operated via a separate channel.

The RC2 control unit is not affected by these settings.

Changing Batteries

CAUTION: Never open the device in potentially explosive atmospheres to change the lithium battery.

When inserting the new lithium batteries, always observe their polarity. These batteries should only be obtained from the company GfG, i.e. the device manufacturer. Internal monitoring ensures that only batteries which meet the demands of the Type Examination are used. The battery type is: **VARTA CR 2430**.

Technical Data	
Type Designation:	RC3
Climatic Conditions:	
for the operation:	-20...+55°C 5...95% r. F. 700...1300hPa
Power Supply:	Lithium battery Typ: VARTA CR 2430 U _n =3V C=280mAh
Housing:	
Material:	plastic
Dimensions:	44 x 61 x 15 mm (W x H x D)
Weight:	20 g
Protection class:	min. IP20
Approvals and Tests:	
Marking and type of protection:	⊕ I M1 Ex ia I Ma ⊕ II 1G Ex ia IIC T6 Ga -20°C≤Ta≤+55°C
EC type-examination certificate:	BVS 08 ATEX E 006 (without measuring function)

Appendix SB1

Operating Instructions

The transmitter supply module SB1 is used to limit the voltage and current of non-intrinsically safe circuits to intrinsically safe values. The non-intrinsically safe circuits are galvanically connected to the intrinsically safe circuits.

A transmitter IR29 connected to the transmitter supply module type SB1 is supplied intrinsically safe. The signals of the IR29 transmitter are read out via a 4-20mA interface and forwarded to an evaluation unit outside the hazardous area. The transmitter supply module is optimally designed for the supply of the transmitters IR29i and IR29Di.

The transmitter supply module SB1 must be installed outside hazardous areas and has an EC type-examination certificate issued by DEKRA EXAM GmbH in accordance with Directive 94/9/EC.

For the SB1 applies:

Certificate: BVS 11 ATEX E 164
 Certification: Ⓢ II (1) G [Ex ia Ga] IIC -20°C ≤ Ta ≤ +55°C

Device Design

Please refer to the table "Technical data" for the maximum values of the voltage, current and power in the intrinsically safe circuits (U_0 , I_0 , P_0) as well as the maximum permissible values of the connected capacities and inductances (C_0 und L_0). The values listed in the table apply to one of the two barrier branches that must be observed separately (relating to PA). Observe the current or voltage additions when interconnecting.

Install Electrical Connections

Input circuit (terminals X1, X2 and X3)	Only for connection to a non-intrinsically safe circuit with a safety-related maximum voltage of $U_m = 253 \text{ V AC}$
Output circuit (terminals X4 and X5)	In ignition protection class 'intrinsically safe' [Ex ia Ga] Characteristics of the circuits: linear (see Technical data)
Signal circuit (terminals X6 and X7)	In ignition protection class 'intrinsically safe' [Ex ia Ga] Characteristics of the circuits: linear (see Technical data)

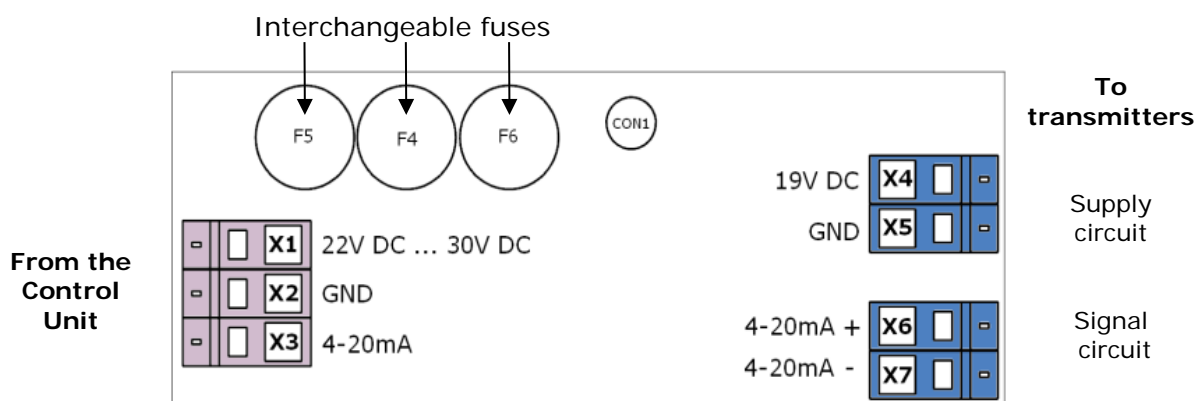

When mounting the transmitter supply module please consider that the connector cables of the not intrinsically safe electric circuit in the SB1 are conducted with a distance of at least 6mm clearance in air to the connector cables of the intrinsically safe electric circuit and accordingly the connector of the display (con1).



The transmitter supply module is equipped with three exchangeable pre-fuses. When replacing the fuses, ensure that only fuse type 164050.0,063 ($I_N=63$ mA) from SIBA is used.
(See Technical data)



As the intrinsically safe circuits are galvanically connected to the earth potential, potential equalization must be provided throughout the entire intrinsically safe circuits.

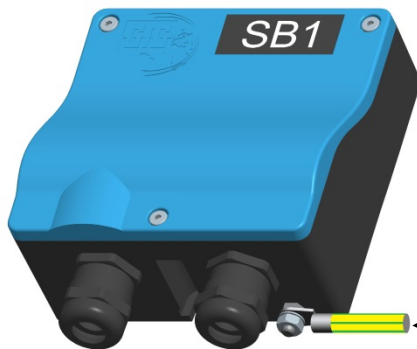

Potential Equalization:

This is located next to the cable entries on the bottom side.

Potential equalization must take place with a line cross section of 4 mm^2 .

Potential Equalization

(13) Appendix to

(14) 3rd Supplement to the EC-Type Examination Certificate
BVS 09 ATEX E 135 X

(15) 15.1 Subject and type

The transmitters may also be manufactured according to the documents listed below, then, they will receive the following labels:

Type	Marking	Connection variant/functionality
IR29 i	II 1G Ex ia IIC T4 Ga I M1 Ex ia I Ma	4-20 mA (intrinsically safe)
IR29 Di	II 1G Ex ia IIC T4 Ga I M1 Ex ia I Ma	4-20 mA (intrinsically safe), with display
IR29	II 2G Ex eb mb Ib [Ib] IIC T4 Gb	4-20 mA (non-intrinsically safe supply and signal circuits)
IR29D	II 2G Ex eb mb Ib [Ib] IIC T4 Gb	4-20 mA (non-intrinsically safe supply and signal circuits), with display
IR29B	II 2G Ex eb mb Ib [Ib] IIC T4 Gb	RS485 (non-intrinsically safe supply and signal circuits)
IR29DB	II 2G Ex eb mb Ib [Ib] IIC T4 Gb	RS485 (non-intrinsically safe supply and signal circuits), with display

15.2 Description

The transmitters serve the stationary measuring of toxic and flammable gases (IR-sensors) in atmospheric conditions.

The transmitters of types IR29 i and IR29 Di are fully constructed for the type of protection Intrinsic Safety and the equipment protection level 'ia'.

The electronic circuit of the transmitters is located on boards of insulating material which are securely fastened in an enclosure of either metal or plastic. The boards of insulating material are partly potted.

The intrinsically safe supply circuit and the intrinsically safe signal circuit (4-20 mA) are both connected by terminals.

The transmitters of types IR29, IR29 D, IR29 B and IR29 DB feature non-intrinsically safe supply and signal circuits. These non-intrinsically safe supply and signal circuits are constructed for the type of protection Increased Safety and the equipment protection level 'eb', and for the type of protection Encapsulation and the equipment protection level 'mb'. The measuring unit is constructed for the type of protection Intrinsic Safety and the equipment protection level 'ib'. The non-intrinsically safe supply and signal circuits are connected via terminals of the type of protection Increased Safety.

In addition, the transmitters are equipped with a four-pole plug connector (intrinsically safe) which may only be connected to the operating unit type RC2 (BVS 04 ATEX E212) for the purpose of parametrisation.

The transmitters are suitable for use in an ambient temperature range of -25°C to +55°C.

Page 2 of 4 to BVS 09 ATEX E 135 X / N3
This certificate may only be reproduced in its entirety and without change.
DEKRA EXAM GmbH, Dimmendahlstrasse 9, 44809 Bochum, Germany
Phone +49 234 3696-105, Fax +49 234 3696-110, E-mail ps-waer@dekra.com



Translation
3rd Supplement to the
EC-Type Examination Certificate

- (1) Equipment and protective systems intended for use in potentially explosive atmospheres - Directive 94/9/EC Supplement according with Annex III number 6
- (2) No. of EC-Type Examination Certificate: BVS 09 ATEX E 135 X
- (3) Equipment: Transmitter types IR29 i, IR29 Di, IR29, IR29D, IR29B, IR29DB
- (4) Manufacturer: GFG Gesellschaft für Gerätebau mbH
- (5) Address: Klönnestr. 99, 44143 Dortmund, Germany

The design and construction of this equipment and any acceptable variation thereto are specified in the appendix to this supplement.

The certification body of DEKRA EXAM GmbH, notified body no. 0158 in accordance with Article 9 of the Directive 94/9/EC of the European Parliament and the Council of 23 March 1994, certifies that this equipment has been found to comply with the Essential Health and Safety Requirements relating to the design and construction of equipment and protective systems intended for use in potentially explosive atmospheres, given in Annex II to the Directive. The examination and test results are recorded in the test and assessment report BVS PP 10.2190 EG.

The Essential Health and Safety Requirements are assured by compliance with:

- EN 60079-0:2012 + A11:2013 General requirements
- IEC 60079-7:2015 Increased Safety 'e'
- EN 60079-11:2012 Intrinsic Safety 'i'
- EN 60079-18:2015 Encapsulation 'm'
- EN 50303:2000 Equipment for Group I, Category M1

If the sign "X" is placed after the certificate number, it indicates that the equipment is subject to special conditions for safe use specified in the appendix to this certificate.

This supplement to the EC-Type Examination Certificate relates only to the design, examination and tests of the specified equipment in accordance to Directive 94/9/EC.

Further requirements of the Directive apply to the manufacturing process and supply of this equipment. These are not covered by this certificate.

- (12) The marking of the equipment shall include the following:
 II 1G Ex ia IIC T4 Ga for types IR29 i, IR29 Di
 I M1 Ex ia I Ma
 II 2G Ex eb mb Ib [Ib] IIC T4 Gb for types IR29, IR29D, IR29B, IR29DB

DEKRA EXAM GmbH
Bochum, dated 2016-03-07

Signed: Simanski Certification body Signed: Dr. Wittler Special services unit

Page 1 of 4 to BVS 09 ATEX E 135 X / N3
This certificate may only be reproduced in its entirety and without change.
DEKRA EXAM GmbH, Dimmendahlstrasse 9, 44809 Bochum, Germany
Phone +49 234 3696-105, Fax +49 234 3696-110, E-mail ps-waer@dekra.com





15.3 Parameters

- 15.3.1 Transmitter of types IR29 I and IR29 Di
 - 15.3.1.1 Intrinsically safe supply circuit, connected via terminals X1 and X2

Maximum input voltage	U _i	DC 30 V
Maximum internal capacitance	C _i	11 nF
Maximum internal inductance	L _i	negligible
 - 15.3.1.2 Intrinsically safe signal circuit (4-20 mA), connected via terminals X3 and X4

Maximum input voltage	U _i	DC 30 V
Maximum internal capacitance	C _i	1.8 nF
Maximum internal inductance	L _i	negligible
- The intrinsically safe signal circuit is safely galvanically separated from the intrinsically safe supply circuit by the sum of its peak values of the nominal voltages of 60 V.
- 15.3.1.3 Intrinsically safe and potential-free opto-coupling interface, connected by four-pole plugs
 - Only for starting up operating unit type RC2 (BVS 04 ATEX E212)

Ambient temperature range	-25 °C to +55 °C
---------------------------	------------------
- 15.3.2 Transmitter of types IR29 and IR29D
 - 15.3.2.1 Non-intrinsically safe supply and signal circuit (4-20 mA), supply, connected via terminals X1(+)-X2 (GND) signal, connected via terminals X1(+)-X5 (4-20mA)

Rated supply voltage	up to	DC 30 V
Rated signal voltage	up to	DC 30 V
Maximum voltage	U _m	DC 45 V
 - 15.3.2.2 Intrinsically safe and potential-free opto-coupling interface, connected by four-pole plugs
 - Only for starting up operating unit type RC2 (BVS 04 ATEX E212)

Ambient temperature range	-25 °C to +55 °C
---------------------------	------------------
- 15.3.3 Transmitter of types IR29B and IR29DB
 - 15.3.3.1 Non-intrinsically safe supply circuit, connected via terminals X1/X5 (+) - X2/X6 (GND)

Rated supply voltage	up to	DC 30 V
Maximum voltage	U _m	DC 45 V
 - 15.3.3.2 Non-intrinsically safe signal circuit (RS485), connected via terminals X3/X7 (RS485+)-X4/X8 (RS485-)

Rated signal voltage	up to	DC 20 V
Maximum voltage	U _m	DC 45 V
 - 15.3.3.3 Non-intrinsically safe internal bus termination resistor (RS485), actuated by wire bridge, actuated by terminals X8-X9
 - Only for connecting a wire bridge
 - 15.3.3.4 Intrinsically safe and potential-free opto-coupling interface, connected by four-pole plugs
 - Only for starting up operating unit type RC2 (BVS 04 ATEX E212)

Ambient temperature range	-25 °C to +55 °C
---------------------------	------------------

- (16) Test and assessment report
BVS PP 10.2190 EG, as of 2016-03-07
- (17) Special conditions for safe use
The measuring function for explosion protection is not subject of this EC-type examination certificate.

We confirm the correctness of the translation from the German original.
In the case of arbitration only the German wording shall be valid and binding.

DEKRA EXAM GmbH
44809 Bochum, 2016-03-30
BVS-Rip/At E 5664/16

W. H. H.
Certification body

[Signature]
Special services unit



Page 4 of 4 to BVS 09 ATEX E 135 X / N3
This certificate may only be reproduced in its entirety and without change.
DEKRA EXAM GmbH, Dinnendahlstrasse 9, 44809 Bochum, Germany
Phone +49 234 3696-105, Fax +49 234 3696-110, E-mail bs-exam@dekra.com



Page 5 of 4 to BVS 09 ATEX E 135 X / N3
This certificate may only be reproduced in its entirety and without change.
DEKRA EXAM GmbH, Dinnendahlstrasse 9, 44809 Bochum, Germany
Phone +49 234 3696-105, Fax +49 234 3696-110, E-mail bs-exam@dekra.com

EU Declaration of Conformity GfG Gesellschaft für Gerätebau mbH

IR29 i, IR29 Di

Klönnestraße 99
44143 Dortmund
Tel: +49 (231) 56400-0
Fax: +49 (231) 516313
E-Mail: info@gfg-mbh.com
www.gfg.biz

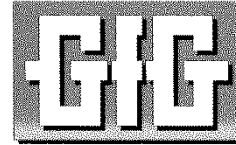

Edited: 03.08.2010 Amended: 08.08.2017

GfG Gesellschaft für Gerätebau mbH develops produces and sells gas sensors and gas warning devices which are subject to a **quality management system** as per DIN EN ISO 9001. Subject to supervision by means of a **quality system**, surveilled by the notified body, DEKRA EXAM GmbH (0158), is the production of electrical apparatus of instrumentation Group I and II, categories M1, M2, 1G and 2G for gas sensors, gas detectors, gas warning systems in types of protection flameproof enclosures, increased safety, encapsulation and intrinsic safety, as well as their measuring function.

The transmitter **IR29 i, IR29 Di** complies with directive **2014/34/EU** (ATEX) for devices and protective systems for proper use in potentially explosive atmospheres, directive **2014/30/EU** for electromagnetic compatibility and with directive **2011/65/EU** (RoHS) on the restriction of the use of certain hazardous substances in electrical and electronic equipment.

**For electrical explosion protection
Labelling**

BVS 09 ATEX E 135 X
⊕ II **1G** Ex ia IIC T4 Ga
⊕ I **M1** Ex ia I Ma

EC-Type Examination Certificate according to directive 94/9/EG

- General requirements	EN 60079-0	: 2012 +A11 :2013
- Intrinsic safety "i"	EN 60079-11	: 2012
- Group1, category-M1-equipment	EN 50303	: 2000

Certified by the notified body with ID number 0158 (DEKRA EXAM, Dinnendahlstraße 9, D-44809 Bochum).

The directive 2014/34/EU is complied considering the following standards:

- General requirements	EN 60079-0	: 2012 +A11 :2013
- Intrinsic safety "i"	EN 60079-11	: 2012
- Group1, category-M1-equipment	EN 50303	: 2000

The rating of the danger of ignition was done and documented.

The directive 2014/30/EU is complied considering the following standard:

- Electromagnetic compatibility - Electrical apparatus for the detection and measurement of combustible gases, toxic gases or oxygen	EN 50270	: 2006
Emitted interference	Type class 1	
Interference immunity	Type class 2	

The EMC test laboratory EM TEST GmbH at Kamen has tested and certified the electromagnetic compatibility.

The directive 2011/65/EU is complied considering the following standard:

- Technical documentation for the assessment of electrical and electronic products with respect to the restriction of hazardous substances	EN 50581	: 2012
--	----------	--------

Dortmund, 14 September 2017

i.V. Siebrecht
.....
B. Siebrecht
QMB

ATEX EU-Ken@77Siebrecht

EU Declaration of Conformity**GfG Gesellschaft für Gerätebau mbH****IR29, IR29 D
IR29 B, IR29 DB**

Klönnestraße 99
 44143 Dortmund
 Tel: +49 (231) 56400-0
 Fax: +49 (231) 516313
 E-Mail: info@gfg-mbh.com
 www.gfg.biz

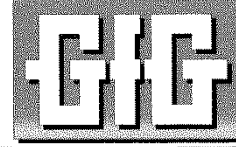

Edited: 17.03.2016 Amended: 08.08.2017

GfG Gesellschaft für Gerätebau mbH develops produces and sells gas sensors and gas warning devices which are subject to a **quality management system** as per DIN EN ISO 9001. Subject to supervision by means of a **quality system**, surveilled by the notified body, DEKRA EXAM GmbH (0158), is the production of electrical apparatus of instrumentation Group I and II, categories M1, M2, 1G and 2G for gas sensors, gas detectors, gas warning systems in types of protection flameproof enclosures, increased safety, encapsulation and intrinsic safety, as well as their measuring function.

The transmitter **IR29, IR29 D, IR29 B, IR29 DB** complies with directive **2014/34/EU** (ATEX) for devices and protective systems for proper use in potentially explosive atmospheres, directive **2014/30/EU** for electromagnetic compatibility and with directive **2011/65/EU** (RoHS) on the restriction of the use of certain hazardous substances in electrical and electronic equipment.

**For electrical explosion protection
 Labelling**

BVS 09 ATEX E 135 X
 Ⓢ II **2G** Ex eb mb ib [ib] IIC T4 Gb

EC-Type Examination Certificate according to directive 94/9/EG

- General requirements	EN 60079-0	: 2012 + A11:2013
- Increased safety "e"	EN 60079-7	: 2015
- Intrinsic safety "i"	EN 60079-11	: 2012
- Encapsulation "m"	EN 60079-18	: 2015

Certified by the notified body with ID number 0158 (DEKRA EXAM, Dinnendahlstraße 9, D-44809 Bochum).

The directive 2014/34/EU is complied considering the following standards:

- General requirements	EN 60079-0	: 2012 + A11:2013
- Increased safety "e"	EN 60079-7	: 2015
- Intrinsic safety "i"	EN 60079-11	: 2012
- Encapsulation "m"	EN 60079-18	: 2015

The rating of the danger of ignition was done and documented.

The directive 2014/30/EU is complied considering the following standard:

- Electromagnetic compatibility - Electrical apparatus for the detection and measurement of combustible gases, toxic gases or oxygen	EN 50270	: 2006
Emitted interference	Type class 1	
Interference immunity	Type class 2	

The EMC test laboratory EM TEST GmbH at Kamen has tested and certified the electromagnetic compatibility.

The directive 2011/65/EU is complied considering the following standard:

- Technical documentation for the assessment of electrical and electronic products with respect to the restriction of hazardous substances	EN 50581	: 2012
--	----------	--------

Dortmund, 14 September 2017

B. Siebrecht

 B. Siebrecht
 QMB

ATEX EU-Kenn09/Siebrecht

EU Declaration of Conformity**GfG Gesellschaft für Gerätebau mbH****Remote Control
RC3**

Klönnestraße 99
44143 Dortmund
Tel: +49 (231) 56400-0
Fax: +49 (231) 516313
E-Mail: info@gfg-mbh.com
www.gfg.biz

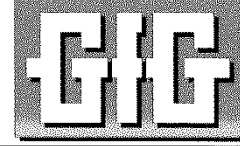

Edited: 24.03.2010 Amended: 08.08.2017

GfG Gesellschaft für Gerätebau mbH develops produces and sells gas sensors and gas warning devices which are subject to a **quality management system** as per DIN EN ISO 9001. Subject to supervision by means of a **quality system**, surveilled by the notified body, DEKRA EXAM GmbH (0158), is the production of electrical apparatus of instrumentation Group I and II, categories M1, M2, 1G and 2G for gas sensors, gas detectors, gas warning systems in types of protection flameproof enclosures, increased safety, encapsulation and intrinsic safety, as well as their measuring function.

The Remote Control **RC3** complies with directive **2014/34/EU** (ATEX) for devices and protective systems for proper use in potentially explosive atmospheres, directive **2014/30/EU** for electromagnetic compatibility and with directive **2011/65/EU** (RoHS) on the restriction of the use of certain hazardous substances in electrical and electronic equipment.

**For electrical explosion protection
Labelling**

BVS 08 ATEX E 006
⊕ II **1G** Ex ia IIC T6 Ga
⊕ I **M1** Ex ia I Ma

EC-Type Examination Certificate according to directive 94/9/EG

- General requirements	EN 60079-0	: 2009
- Intrinsic safety "i"	EN 60079-11	: 2007
- Group II category 1 G	EN 60079-26	: 2007
- Group1, category-M1-equipment	EN 50303	: 2000

Certified by the notified body with ID number 0158 (DEKRA EXAM, Dinnendahlstraße 9, D-44809 Bochum).

The directive 2014/34/EU is complied considering the following standards:

- General requirements	EN 60079-0	: 2012 +A11 :2013
- Intrinsic safety "i"	EN 60079-11	: 2012
- Group II category 1 G	EN 60079-26	: 2015
- Group I, category-M1-equipment	EN 50303	: 2000

The rating of the danger of ignition was done and documented.

The directive 2014/30/EU is complied considering the following standard:

- Electromagnetic compatibility - Electrical apparatus for the detection and measurement of combustible gases, toxic gases or oxygen	EN 50270	: 2006
Emitted interference	Type class 1	
Interference immunity	Type class 2	

The EMC test laboratory EM TEST GmbH at Kamen has tested and certified the electromagnetic compatibility.

The directive 2011/65/EU is complied considering the following standard:

- Technical documentation for the assessment of electrical and electronic products with respect to the restriction of hazardous substances	EN 50581	: 2012
--	----------	--------

Dortmund, 14 September 2017

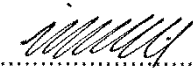
.....
i.v. 
B. Siebrecht
QMB



Translation

EC-Type Examination Certificate

- (1) Equipment and protective systems intended for use in potentially explosive atmospheres - Directive 94/9/EC
- (2) No. of EC-Type Examination Certificate: **BVS 11 ATEX E 164**
- (3) Equipment: **Power supply module for transmitters, types SB1 and SB1D**
- (4) Manufacturer: **GfG Gesellschaft für Gerätebau mbH**
- (5) Address: **44143 Dortmund, Germany**
- (6) The design and construction of this equipment and any acceptable variation thereto are specified in the appendix to this type examination certificate.
- (7) The certification body of DEKRA EXAM GmbH, notified body no. 0158 in accordance with Article 9 of the Directive 94/9/EC of the European Parliament and the Council of 23 March 1994, certifies that this equipment has been found to comply with the Essential Health and Safety Requirements relating to the design and construction of equipment and protective systems intended for use in potentially explosive atmospheres, given in Annex II to the Directive. The examination and test results are recorded in the test and assessment report BVS PP 11.2241 EG.
- (8) The Essential Health and Safety Requirements are assured by compliance with:
 - EN 60079-0:2009** **General requirements**
 - EN 60079-11:2007** **Type of Intrinsic Safety 'i'**
 - EN 60079-26:2007** **Equipment with EPL 'Ga'**
- (9) If the sign "X" is placed after the certificate number, it indicates that the equipment is subject to special conditions for safe use specified in the appendix to this certificate.
- (10) This EC-Type Examination Certificate relates only to the design, examination and tests of the specified equipment in accordance to Directive 94/9/EC. Further requirements of the Directive apply to the manufacturing process and supply of this equipment. These are not covered by this certificate.
- (11) The marking of the equipment shall include the following:

 **II (1)G [Ex ia Ga] IIC**

DEKRA EXAM GmbH
Bochum, dated 16th November 2011

Signed: Simanski

Signed: Dr. Wittler

Certification body

Special services unit



(13) Appendix to

(14) **EC-Type Examination Certificate**
BVS 11 ATEX E 164

(15) 15.1 Subject and type

Power supply module for transmitters type SB1 (variant without display)
type SB1D (variant with display to show data)

15.2 Description

The power supply module for transmitters of types SB1 and SB1D is installed outside the potentially explosive atmosphere; it is used for supplying power to intrinsically safe transmitters and for transmitting signals of 4...20 mA between the intrinsically safe and non-intrinsically safe signal circuits. The electronic circuit of the power supply module is fastened onto boards of insulating materials which are partly potted and securely installed into a plastic enclosure.

The intrinsically safe circuits of the type of protection Ex ia can be led into atmospheres which require equipment of category 1G (EPL Ga).

The intrinsically safe supply circuit and the intrinsically safe signal circuit as well as the non-intrinsically safe supply/signal circuit are galvanically interconnected by their reference conductors and also to the connection for equipotential bonding.

15.3 Parameters

15.3.1 Non-intrinsically safe circuits

15.3.1.1 Non-intrinsically safe supply circuit, connected via terminals X1 (+) - X2 (GND)

Rated voltage		DC	22 ... 30 V
Maximum voltage	U_m	AC	253 V

15.3.1.2 Non-intrinsically safe signal circuit, connected via terminals X3 (4-20mA) - X2 (GND)

Rated voltage		DC	22 ... 30 V
Maximum voltage	U_m	AC	253 V

15.3.2 Intrinsically safe output circuits of type of protection Ex ia IIC

15.3.2.1 Intrinsically safe supply circuit, connected via terminals X4 (+) – X5 (GND)

Maximum output voltage	U_o	DC	21 V
Maximum output current	I_o		161 mA
Maximum output power	P_o		844 mW
Maximum external capacitance	C_o		180 nF
Maximum external inductance	L_o		1 mH

15.3.2.2 Intrinsically safe signal circuit, connected via terminals X6 (4-20mA +) – X7 (4-20 mA -)

Maximum output voltage	U_o	DC	21 V
Maximum output current	I_o		161 mA
Maximum output power	P_o		844 mW
Maximum external capacitance	C_o		180 nF
Maximum external inductance	L_o		1 mH

15.3.3 Ambient temperature range -20°C to +55°C



(16) Test and assessment report

BVS PP 11.2241 EG as of 16.11.2011

(17) Special conditions for safe use

Not applicable

We confirm the correctness of the translation from the German original.
In the case of arbitration only the German wording shall be valid and binding.

DEKRA EXAM GmbH
44809 Bochum, 08.03.2012
BVS-Rip/Ar E 0282/12

Certification body

Special services unit

EU Declaration of Conformity GfG Gesellschaft für Gerätebau mbH

**SB1
SB1 D**

Klönnestraße 99
44143 Dortmund
Tel: +49 (231) 56400-0
Fax: +49 (231) 516313
E-Mail: info@gfg-mbh.com
www.gfg.biz



Edited: 20.12.2011 Amended: 08.08.2017

GfG Gesellschaft für Gerätebau mbH develops produces and sells gas sensors and gas warning devices which are subject to a **quality management system** as per DIN EN ISO 9001. Subject to supervision by means of a **quality system**, surveilled by the notified body, DEKRA EXAM GmbH (0158), is the production of electrical apparatus of instrumentation Group I and II, categories M1, M2, 1G and 2G for gas sensors, gas detectors, gas warning systems in types of protection flameproof enclosures, increased safety, encapsulation and intrinsic safety, as well as their measuring function.

The transmitter supply module **SB1, SB1 D** complies with directive **2014/34/EU** (ATEX) for devices and protective systems for proper use in potentially explosive atmospheres, directive **2014/30/EU** for electromagnetic compatibility and with directive **2011/65/EU** (RoHS) on the restriction of the use of certain hazardous substances in electrical and electronic equipment.

**For electrical explosion protection
Labelling**

BVS 11 ATEX E 164
⊕ II **(1)G** [Ex ia Ga] IIC

EC-Type Examination Certificate according to directive 94/9/EG

- General requirements EN 60079-0 : 2009
- Intrinsic safety "i" EN 60079-11 : 2007
- Group II category 1G EN 60079-26 : 2007

Certified by the notified body with ID number 0158 (DEKRA EXAM, Dinnendahlstraße 9, D-44809 Bochum).

The directive 2014/34/EU is complied considering the following standards:

- General requirements EN 60079-0 : 2012 +A11 :2013
- Intrinsic safety "i" EN 60079-11 : 2012
- Group II category 1G EN 60079-26 : 2015

The rating of the danger of ignition was done and documented.

The directive 2014/30/EU is complied considering the following standard:

- Electromagnetic compatibility - Electrical apparatus for the detection and measurement of combustible gases, toxic gases or oxygen EN 50270 : 2006
- Emitted interference Type class 1
- Interference immunity Type class 2

The EMC test laboratory EM TEST GmbH at Kamen has tested and certified the electromagnetic compatibility.

The directive 2011/65/EU is complied considering the following standard:

- Technical documentation for the assessment of electrical and electronic products with respect to the restriction of hazardous substances EN 50581 : 2012

Dortmund, 14 September 2017

i.V. MMB
.....
B. Siebrecht
QMB