

Technical Instructions for Correlation Sensors and external Electronic Box

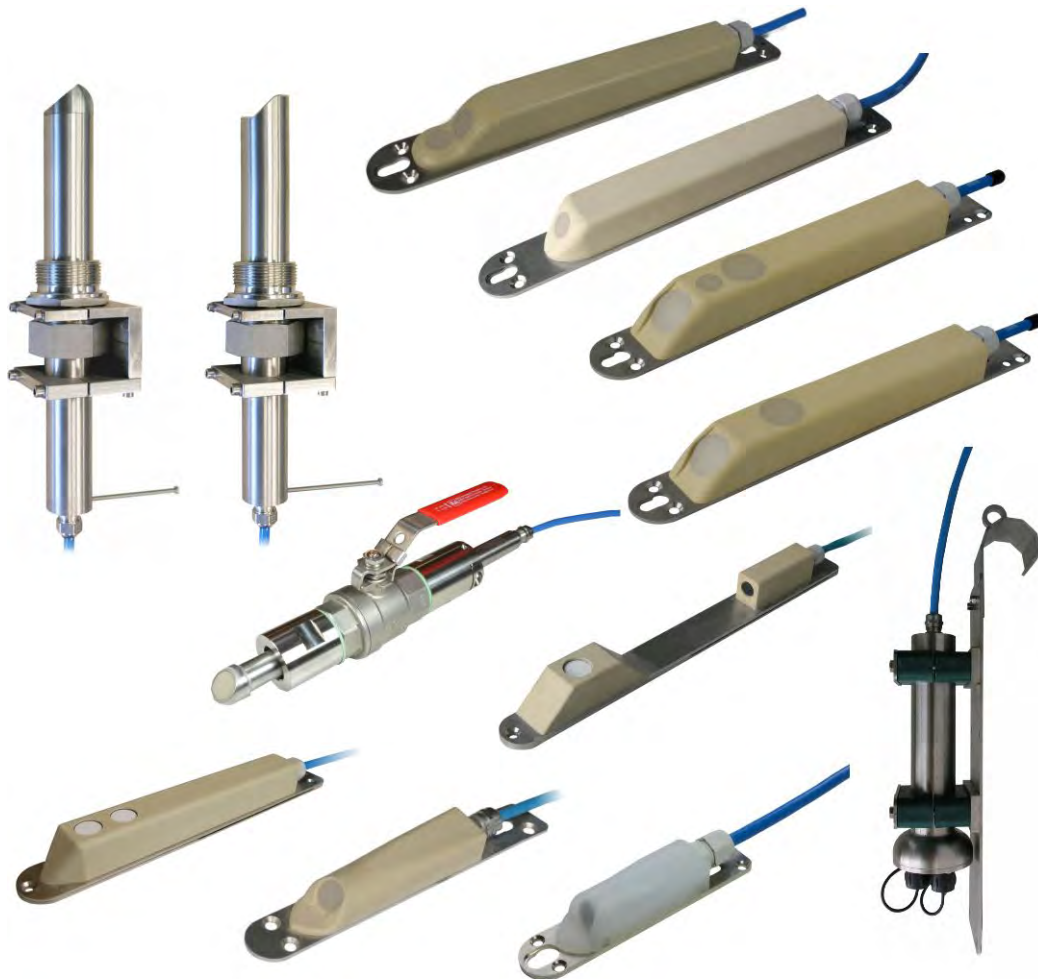

Revised Manual

Document revision 09 / 01.10.2019

Original Technical Instructions: German, rev 09 as of 25.09.2019

Nivus AG

Burgstraße 28
8750 Glarus, Schweiz
Phone: +41 (0)55 6452066
Fax: +41 (0)55 6452014
swiss@nivus.com
www.nivus.de

NIVUS Austria

Mühlbergstraße 33B
3382 Loosdorf, Österreich
Phone: +43 (0) 2754 567 63 21
Fax: +43 (0) 2754 567 63 20
austria@nivus.com
www.nivus.de

NIVUS Sp. z o.o., Poland

ul. Hutnicza 3 / B-18
81-212 Gdynia, Polen
Phone: +48 (0) 58 7602015
Fax: +48 (0) 58 7602014
biuro@nivus.pl
www.nivus.pl

NIVUS France

17, rue du Stade
67870 Bischoffsheim, France
Phone: +33 (0)3 88 9992 84
info@nivus.fr
www.nivus.fr

NIVUS Ltd., United Kingdom

Wedgewood Rugby Road
Weston under Wetherley
Royal Leamington Spa
CV33 9BW, Warwickshire
Phone: +44 (0)8445 3328 83
nivusUK@nivus.com
www.nivus.com

NIVUS Middle East (FZE)

Building Q 1-1 ap. 055
P.O. Box: 9217
Sharjah Airport International
Free Zone
Phone: +971 6 55 78 224
Fax: +971 6 55 78 225
middle-east@nivus.com
www.nivus.com

NIVUS Korea Co. Ltd.

#2502 M Dong, Technopark IT Center,
32 Song-do-gwa-hak-ro, Yeon-su-gu,
INCHEON, Korea 21984
Phone: +82 32 209 8588
Fax: +82 32 209 8590
korea@nivus.com
www.nivus.com

NIVUS Vietnam

21 Pho Duc Chinh, Ba Dinh
Hanoi, Vietnam
Phone: +84 12 0446 7724
vietnam@nivus.com
www.nivus.com

Copyrights and property rights

This document and its contents are proprietary to NIVUS GmbH and are not to be reproduced or copied without the express written permission of NIVUS GmbH.

Violations oblige to compensation.



Important Note

This instruction manual may exclusively - even in parts - be copied or translated in any other way with the express written consent of NIVUS GmbH.

Translation

If the device is sold to a country in the European Economic Area (EEA) this Technical Instructions must be translated into the language of the country in which the device is to be used.

Should the translated text be unclear, the original Technical Instructions (German) must be consulted or the NIVUS GmbH contacted for clarification.

Copyright

No part of this publication may be reproduced, transmitted, sold or dis-closed without prior permission. Damages will be claimed for violations. All rights reserved.

Names

The use of general descriptive names, trade names, trademarks and the like in this handbook does not entitle the reader to assume they may be used freely by everyone. They are often protected registered trademarks even if not marked as such.

Change History

Rev.	Date	Changes	Editor
09	01.10.2019	Canges: Chapt. 2.7, Chapt. 4.5.3 Creation: Chapt. 6.6 Corrections: Chap. 3.1, Fig. 4.7, Fig. 4-11, Chapt. 4.3, Fig. 6-2, Fig. 6-3, orthographic mistakes	KG
08	08.03.2019	Complete Revision	KG

Table of contents

Copyrights and property rights	3
Change History	4
1 General	8
1.1 Applicable documentation.....	8
1.2 Signs and definitions used.....	9
1.3 Abbreviations used	9
2 Safety Instructions	10
2.1 Used symbols and signal words	10
2.2 Safeguards and Precautions	11
2.3 Personnel requirements.....	12
2.4 Ex-Approval	12
2.5 Intended Use	13
2.6 Users's Responsibilities.....	14
2.6.1 Keep Manual	14
2.6.2 Provide Manual.....	14
2.7 Disclaimer	15
3 Delivery, Storing and Transport	16
3.1 Delivery.....	16
3.2 Reciept.....	16
3.3 Storing.....	16
3.4 Transport	16
3.5 Return	16
4 Product Specification	17
4.1 Sensor Overview	17
4.2 Sensor Design and Dimensions	19
4.2.1 Senor Type CSM-V100K.....	19
4.2.2 Senor CSM-V1D0K	20
4.2.3 Sensor CSM-V100R	21
4.2.4 Sensor DSM	22
4.2.5 Electronic Box EBM.....	23
4.2.6 Sensor POA-....K	26
4.2.7 Sensor POA-....R	28
4.2.8 Sensor OCL.....	31
4.2.9 Sensor CS2-....K.....	32
4.2.10 Sensor CS2-....R.....	34

4.2.11	Sensor CSP	36
4.3	Device identification	37
4.4	Sensor versions	42
4.4.1	Type Key for Sensor CSM	42
4.4.2	Type Key for Sensor DSM	43
4.4.3	Type Key for Electronic Box EBM	43
4.4.4	Type Key for Sensor POA	44
4.4.5	Type Key for Sensor OCL	45
4.4.6	Type Key for Sensor CS2	46
4.4.7	Type Key for Sensor CSP	47
4.5	Specification	48
4.5.1	Sensor CSM-V100K	48
4.5.2	Sensor CSM-V1D0K	49
4.5.3	Sensor CSM-V100R	50
4.5.4	Sensor DSM	51
4.5.5	Electronic Box EBM	51
4.5.6	Sensor POA	52
4.5.7	Sensor OCL	53
4.5.8	Sensor CS2	54
4.5.9	Sensor CSP	55
5	Installation	57
5.1	Installation Instructions	57
5.1.1	Electrical Installation	57
5.1.2	Notes on Sensor Installation	58
5.2	Mounting the protection hose for the sensors CS2 and CSP	59
5.3	Plug wiring and Sensor Cable	60
5.3.1	Sensors CSM and CSP	60
5.3.2	Sensor DSM	60
5.3.3	Electronic Box EBM	61
5.3.4	Sensors POA and CS2	61
5.3.5	Sensor OCL	63
5.4	Cable extension	63
5.5	Pressure compensation elements	66
5.5.1	General	66
5.5.2	Pressure compensation element for CSM and CSP Sensors	67
5.5.3	Pressure compensation element for POA- and CS2- sensors	68
5.6	Table of Resistiveness	73
5.6.1	Resistiveness Legend	75

6	Cleaning and Maintenance	76
6.1	Basics of Cleaning	76
6.2	Cleaning wedge sensors	76
6.3	Maintenance wedge sensors.....	77
6.3.1	Wedge Sensors with Pressure Measurement Cell.....	77
6.3.2	Pressure Compensation Element for CSM and CSP Sensors.....	78
6.3.3	Pressure Compensation Element for POA and CS2 Sensor	78
6.4	Cleaning and maintenance sensors OCL and DSM.....	80
6.5	Cleaning and maintenance pipe sensors POA and CS2.....	81
6.6	Cleaning and maintenance pipe sensor CSM.....	82
6.7	Installation of Spare Parts and Parts subject to wear and tear	84
6.8	Customer Service Information	85
7	Dismantling/Disposal.....	86
8	Accessories and Spare Parts	87
	Index.....	88
	Certificates and approvals.....	90

1 General



Important

READ CAREFULLY BEFORE USE

KEEP IN A SAFE PLACE FOR LATER REFERENCE.

This Technical instruction is an original instruction for Correlation Sensors and external Electronic Box is intended for the initial start-up or the connection of the sensors. This manual is oriented exclusively to qualified expert personnel.

Read this Technical instruction carefully and completely prior to installation and connection since it contains relevant information on this product. Observe the notes and particularly follow the warning notes and safety instructions.

If you should have problems to understand information contained within this Technical Instruction either contact the NIVUS GmbH or one of the distributors for further support. The legally associated companies and subsidiaries of NIVUS group cannot be held responsible for damage to persons or material due to incorrectly understood information in this instruction.



1.1 Applicable documentation

For the installation and operation of the complete system extra instruction manuals or technical descriptions may be required apart from this manual.

- Instruction manual for NivuFlow, NivuFlow Mobile, Nivus Full Pipe, OCM Pro and PCM Pro transmitters.
- Installation Instruction for Correlation and Doppler Sensors
- Installation Instruction for pipe mounting systems
- Instruction manual for Nivus Pipe Profiler (NPP)

These manuals are provided with the auxiliary units or sensors and/or are available as download on the NIVUS homepage.

1.2 Signs and definitions used

Image	Meaning	Remark
	Creoss-reference	Reference to further or detailed information.
>Text<	Parameter or Menu	Indicates a parameter or a menu that is selected or described.
	Reference to document	Refers to an accompanying documentation.

1.3 Abbreviations used

Colour code for wires and single conductors

The abbreviations of colours, wire and components follow the international colour code according IEC 60757.

BK	black	BN	brown	RD	red
OG	orange	YE	yellow	GN	green
BU	blue	VT	violet	GY	grey
WH	white	PK	pink	TQ	turquoise
GNYE	green/yellow	GD	gold	SR	silver

Article Names

- CSM cross correlation sensor of the Mini sensor family
- DSM air-ultrasonic sensor of the Mini sensor family
- EBM electronic box for the Mini sensor family
- POA cross correlation sensor for full and partial filling
- OCL air-ultrasonic sensor
- CS2 cross correlation sensor for full and partial filling
- CSP cross correlation sensor for full and partial filling

2 Safety Instructions

2.1 Used symbols and signal words



*The general warning symbol indicates the risk of personal injuries or death.
In the text section the general warning symbol is used in conjunction with the signal words described below*



Warnings in high degree of risk

*Indicates a high-risk, **imminently** hazardous situation which will result in death or serious injury if not avoided.*



Warnings in medium degree of risk

*Indicates a **possible** danger with medium risk which may result in a life-threatening situation or (severe) bodily injury if it is not avoided. .*



Warnings in low-risk or property damages

Indicates a possible danger with moderate risk which may result in minor or moderate personal injury or material damage if not avoided.



Danger by electric voltage

Indicates a hazard with a high risk of electric shock which may result in a life-threatening situation or (severe) bodily injury if it is not avoided.



Important Note

*Contains information that should be highlighted.
Indicates a potentially damaging situation which can result in a damage of the product or an object in its environment.*



Note

Contains information and facts.

2.2 Safeguards and Precautions

Working with NIVUS instruments requires to observe and to follow the safety measures and precautions below generally and at any time. These notes and warnings will not be repeated for each description within the document.

WARNING

Germ contamination



Please note that due to the operation in the waste water field the measurement system and cables may be loaded with dangerous disease germs. Respective precautionary measures must be taken to avoid damage to one's health.

Wear protective clothing.

WARNING

Observe regulations for health and safety at work



Installation, mounting, commissioning and maintenance shall be executed by appropriately trained expert personnel. Before starting installation work, observing the work safety regulations need to be checked.

Disregarding may lead in personal injury.

WARNING

Do not disable safety devices!



It is strictly prohibited to disable the safety devices or to change the way they work.

Disregarding may lead in personal injury.

WARNING

Check danger through explosive gases



Prior to beginning mounting, installation and maintenance make sure to observe any regulations on safety at work as well as to check the potential risk due to explosive gases.

When working in the channel system make sure to avoid electrostatic charge:

- *Avoid unnecessary movements to minimise the risk of static energy accumulating.*
- *Discharge any possible static electricity from your body before you begin to install sensors.*

Disregarding may lead to personal injury or damage your equipment.

2.3 Personnel requirements

Installation, commissioning and maintenance shall be executed only by personnel meeting the demands as follows:

- Expert personnel with relevant training and appropriate qualification
- Personnel authorised by the plant operator



Qualified personnel

within the context of this documentation or the safety notes on the product itself are persons who are sufficiently familiar with installation, mounting, starting up and operation of the product and who have the relevant qualifications for their work; for example:

- I. *Training, instruction or authorisation to activate/deactivate, isolate, ground, and mark electric circuits and devices/systems according to the safety engineering standards.*
 - II. *Education and instruction according to the standards of safety engineering regarding the maintenance and use of adequate safety equipment.*
 - III. *First aid training*
-

2.4 Ex-Approval

CAUTION



Damages invalidate the Ex protection.

Damage might invalidate the Ex protection.

Protect the sensor from shocks, drops or other damage.

The Ex-version of the sensors is designed to be used in areas with explosive atmospheres (zone 1).

Approval ATEX / IECEx



II 2G Ex ib IIB T4 Gb / Ex ib IIB T4 Gb



Important Note

The approval is only valid in connection with the respective indication on the sensors nameplate.

The Ex-version sensors are matched to the NIVUS transmitters regarding the assessment of intrinsically safe electrical systems according to EN 60079-25.

In case of using other manufacturer's transmitters the operator is obliged to implement a system assessment according to EN 60079-25.

The required specifications for Ex-version sensors can be taken from the EC-type examination certificate TÜV 03 ATEX 2262 or TÜV 12 ATEX 087812

2.5 Intended Use



Important Note

The sensors and the Electronic Box are exclusively intended to be used for purposes as described above. Modifying or using the sensors or Electronic Box for other purposes without the written consent of the NIVUS GmbH will not be considered as use in accordance with the requirements.

The legally associated companies and subsidiaries of NIVUS group cannot be held responsible for any damage resulting from improper use. The user alone bears any risk.

Please necessarily observe the maximum permissible limit values as specified in 4.5 *Specification*. Any cases varying from these conditions without written consent of NIVUS GmbH are entirely left at owner's risk.

Deviating changes must be approved by NIVUS GmbH in written form.



Note

For installation and commissioning observe the points below:

- *declaration of conformity*
- *test certificates of the respective authorities*
- *applicable national regulations*

Sensor	Measurement	Medium	Area of application	Connection to transmitter
OCL	Level	Air	Part filled flow measurement places	NF750, PCM Pro, PCM 4, OCM Pro CF
POA	Flow velocity Level (optional)	Slight to heavily polluted	Part filled or full channels, pipes, flumes	NF7, NFP, PCM Pro, PCM 4, OCM Pro CF
CS2	Flow velocity Level (optional)	Slight to heavily polluted	Part filled or full channels, pipes, flumes with larger dimensions	NF7, PCM Pro, PCM 4, OCM Pro CF
CSP	Flow velocity Level (optional)	Slight to heavily polluted	Part filled or full channels, pipes, flumes with larger dimensions	NFM750
CSM	Flow velocity Level (optional)	Slight to heavily polluted	Part filled or full channels, pipes, flumes with low filling levels	Without EBM: NFM750; With EBM: NF7, PCM Pro, PCM 4
DSM	Level	Air	Pipes with small dimensions	Without EBM: NFM750; With EBM: NF7, PCM Pro, PCM 4

EBM Electronic Box

The Electronic Box Type EBM is conceived to connect the sensors Type CSM and DSM. It contains the detached electronic sensor components and is designed to be connected to Type NivuFlow 750, NivuFlow 7550 PCM Pro, PCM 4 or OCM Pro transmitters.

2.6 Users' Responsibilities



Important Note

In the EEA (European Economic Area) national implementation of the framework directive 89/391/EEC and corresponding individual directives, in particular the directive 2009/104/EC concerning the minimum safety and health requirements for the use of work equipment by workers at work, as amended, are to be observed and adhered to. In Germany e. g. the Industrial Safety Ordinance must be observed.

Make sure to have a local operating permit available and observe the associated conditions. In addition to this you must observe environmental requirements and local laws on the following points:

- Personnel safety (accident prevention regulations)
- Safety of work materials and tools (safety equipment and maintenance)
- Disposal of products (laws on wastes)
- Disposal of materials (laws on wastes)
- Cleaning (cleansing agents and disposal)
- Environmental protection requirements

Connections

Operators shall make sure prior to operating the instrument that during installation and initial start-up the local regulations (such as regulations for electrical connection) are observed.

2.6.1 Keep Manual

Keep this manual in a safe place and make sure it is available for the users of this product at any time.

2.6.2 Provide Manual

This technical description is part of the delivery and must be included with the sensors if they are sold.

2.7 Disclaimer

All legally associated companies and subsidiaries of NIVUS group assume no liability

- for damages owing to **a change** of this document. The legally associated companies and subsidiaries of NIVUS group reserve the right to change the contents of this document and this disclaimer at any time and without any notice.
- for damages to persons or objects resulting from **failure to comply** with applicable **regulations**. For connection, commissioning and operation of the sensors all available information and higher local legal regulations (e.g. in Germany VDE regulations) such as applicable Ex regulations as well as safety requirements and regulations in order to avoid accidents shall be adhered to.
- for damages to persons or objects resulting from **improper use**. For safety and warranty reasons, all internal work on the instruments beyond from that involved in normal installation and connection, must be carried out only by qualified NIVUS personnel or persons or companies authorised by NIVUS.
- for damages to persons or objects resulting from the use of instruments in technically **imperfect** condition.
- for damages to persons or objects resulting from the use of instruments **not in accordance with the requirements**.
- for damages to persons or objects resulting from failure to comply with **safety information** contained within this instruction manual.
- for missing or incorrect measurement values or resulting consequential damages due to **improper installation**.

3 Delivery, Storing and Transport

3.1 Delivery

The standard delivery of the correlation sensors contains:

- This technical instructions with the certificate of conformity and Installation Instruction Correlation and Doppler Sensors. Here, all necessary steps to correctly install and to operate the sensors are listed.
- One correlation sensor and one Electronic Box if required as on the delivery note

Check additional accessories depending on your order and by using the delivery note.

3.2 Receipt

Check the packaging for visible damage immediately after receipt. Any possible damage in transit shall be instantly reported to the carrier. Furthermore a written report shall be sent to NIVUS GmbH in Eppingen.

Incomplete deliveries shall be reported in writing either to your local representative or directly to the NIVUS head office in Eppingen within two weeks.



Note

Mistakes cannot be rectified later.

3.3 Storing

Strictly observe the storing conditions below:

- max. temperature: +70 °C (158 °F)
- min. temperature: -30 °C (-22 °F)
- max. humidity: 100%

When storing, protect the sensors from corrosive or organic solvent vapours, radioactive radiation and strong electromagnetic radiation.

3.4 Transport

Protect the sensors from shock and impact loads and vibrations. Use the original packaging for transport.

3.5 Return

In case of a required reshipment return the sensors at customer cost to NIVUS GmbH in Eppingen using the original packaging.

Insufficiently franked shipments will not be accepted.

4 Product Specification

4.1 Sensor Overview

The sensors depicted below are designed for connection to NIVUS transmitters. You can find an overview on sensors and the appropriate transmitters in *Fig. 4-1* and *Fig. 4-2*.

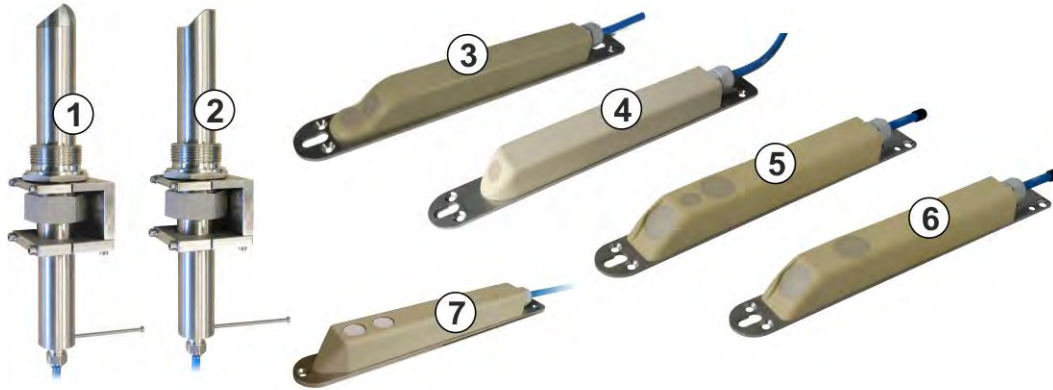

	Sensor	Construction	v-Measurement	h-Measurement	NIVUS Transmitter(s)
1	CS2-....R	Pipe sensor	Cross correlation	-	NivuFlow 750, NivuFlow 7550, PCM Pro, PCM 4, OCM Pro CF
2	POA-....R	Pipe sensor	Cross correlation	Optional: water-ultrasonic	NivuFlow 750, NivuFlow 7550, NFP, PCM Pro, PCM 4, OCM Pro CF
3	POA-V2H1K / POA-V2U1K	Wedge sensor	Cross correlation	Water-ultrasonic or pressure measurement + water-ultrasonic	NivuFlow 750, NivuFlow 7550, PCM Pro, PCM 4, OCM Pro CF
4	POA-V200K / POA-V2D0K	Wedge sensor	Cross correlation	Without or pressure measurement	NivuFlow 750, NivuFlow 7550, (NFP), PCM Pro, PCM 4, OCM Pro CF
5	CS2-....K	Wedge sensor	Cross correlation	None or pressure measurement or water-ultrasonic or pressure measurement + water-ultrasonic	NivuFlow 750, NivuFlow 7550, PCM Pro, PCM 4, OCM Pro CF
6	CSP	Wedge sensor	Cross correlation	None or pressure measurement or water-ultrasonic or pressure measurement + water-ultrasonic	NivuFlow Mobile 750
7	OCL	Wedge sensor	-	Air-ultrasonic	NivuFlow 750, NivuFlow 7550, PCM Pro, PCM 4, OCM Pro CF

Fig. 4-1 Overview sensors CS2, POA, CSP and OCL

Depending on the transmitter used the Mini family sensors additionally require the EBM Electronic Box. The according information can be found in the overview below.

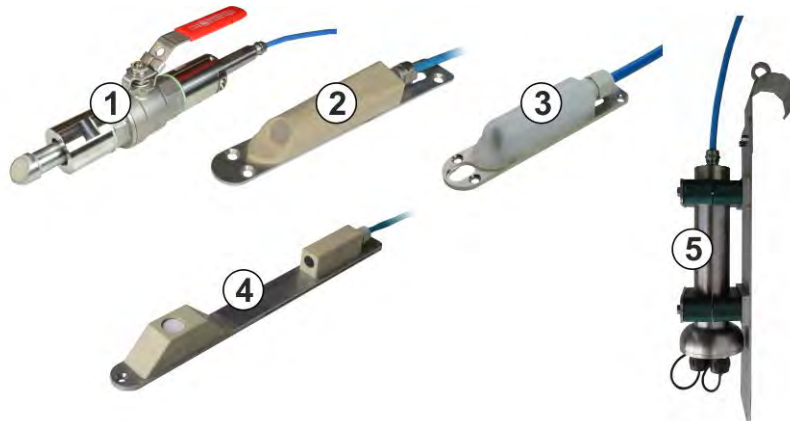

	Sensor / EBM	Construction	v-Measurement	h-Measurement	NIVUS Transmitter(s)	EBM required
1	CSM-V100R7...E	Pipe sensor	Cross correlation	-	NivuFlow 750, PCM Pro, PCM 4, OCM Pro CF	X
	CSM-V100R...R				NivuFlow Mobile 750	-
2	CSM-V1D0K...D	Mini-Wedge Sensor	Cross correlation	Pressure measurement	NivuFlow 750, NivuFlow 7550, PCM Pro, PCM 4, OCM Pro CF	X
	CSM-V1D0K...P				NivuFlow Mobile 750	-
3	CSM-V100K...C	Mini-Wedge Sensor	Cross correlation	-	NivuFlow 750, NivuFlow 7550, PCM Pro, PCM 4, OCM Pro CF	X
	CSM-V100K...M				NivuFlow Mobile 750	-
4	DSM-L0.....B	Mini-Wedge Sensor	-	Air-ultrasonic	NivuFlow 750, NivuFlow 7550, PCM Pro, PCM 4, OCM Pro CF	X
	DSM-L0.....M				NivuFlow Mobile 750	-
5	EBM	Electronic Box				

Fig. 4-2 Overview Mini sensor family

4.2 Sensor Design and Dimensions

4.2.1 Sensor Type CSM-V100K

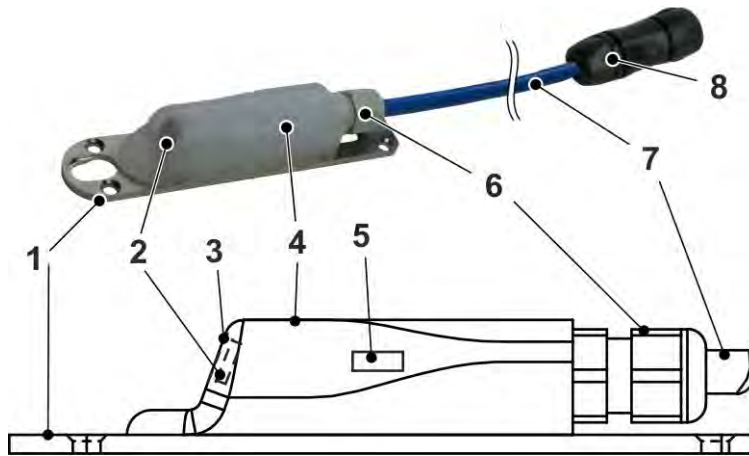

- 1 Ground plate/mounting plate
- 2 Flow velocity sensor
- 3 Acoustic coupling layer
- 4 Sensor body
- 5 Temperature sensor
- 6 Cable gland
- 7 Sensor cable
- 8 Plug with spigot nut

Fig. 4-3 Basic construction sensor CSM-V100K

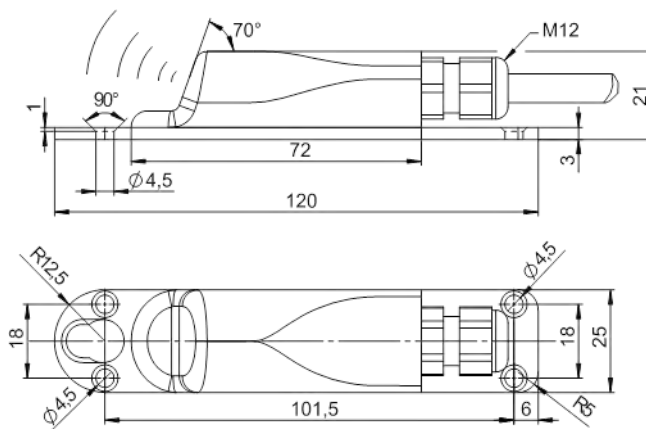
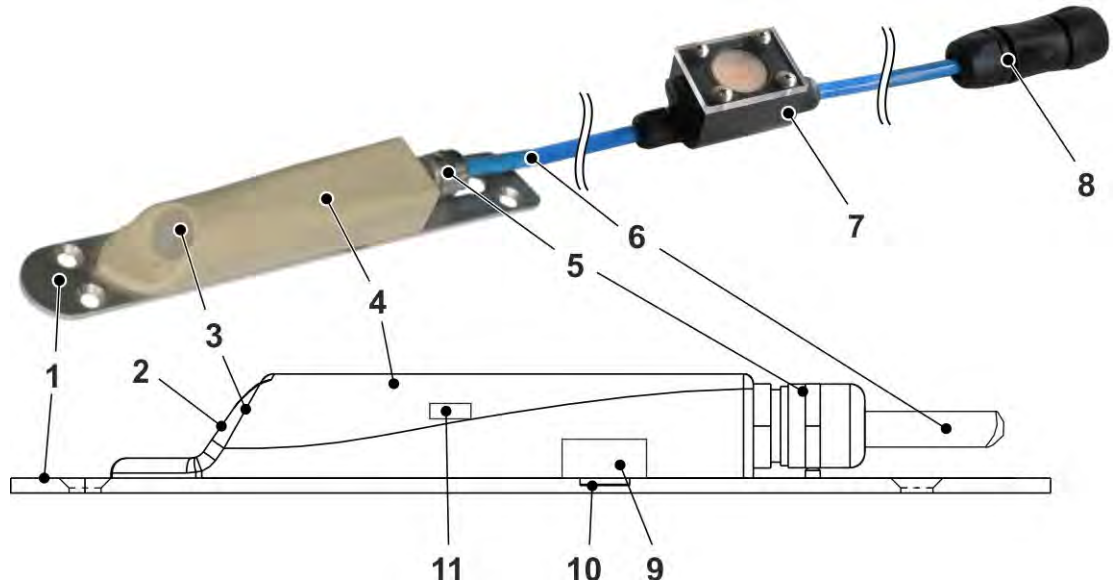

Fig. 4-4 Dimensions sensor CSM-V100K

4.2.2 Senor CSM-V1D0K



- 1 Ground plate/mounting plate
- 2 Acoustic coupling layer
- 3 Flow velocity sensor
- 4 Sensor body
- 5 Cable gland
- 6 Sensor cable
- 7 Pressure compensation element
- 8 Plug with spigot nut
- 9 Pressure measurement cell
- 10 Duct to pressure measurement
- 11 Temperature sensor

Fig. 4-5 Basic construction sensor CSM-V1D0K

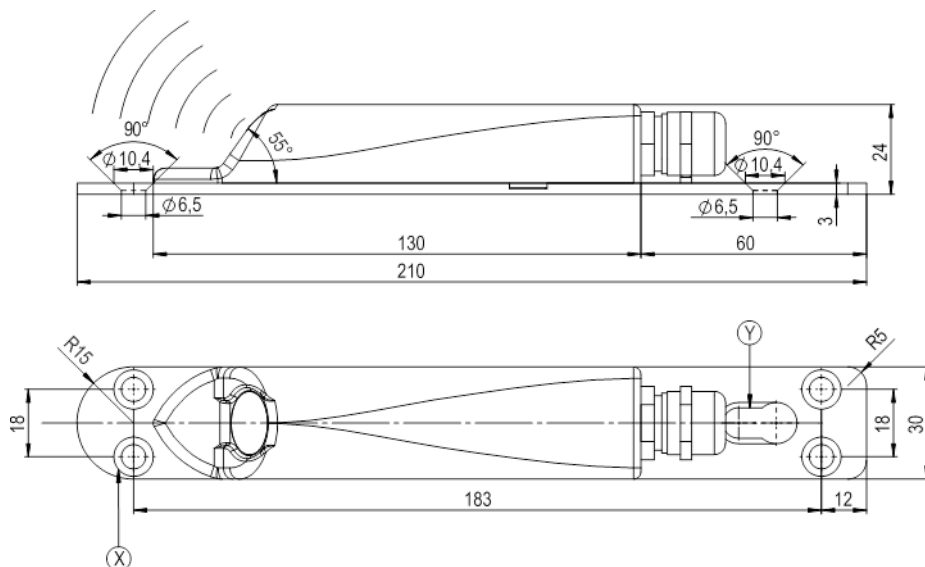

X = 4 x countersunk holes with $d_1 = 6.5$ mm for direct fastening
Y = Slotted hole for fastening on pipe mounting system

Fig. 4-6 Dimensions sensor CSM-V1D0K

4.2.3 Sensor CSM-V100R

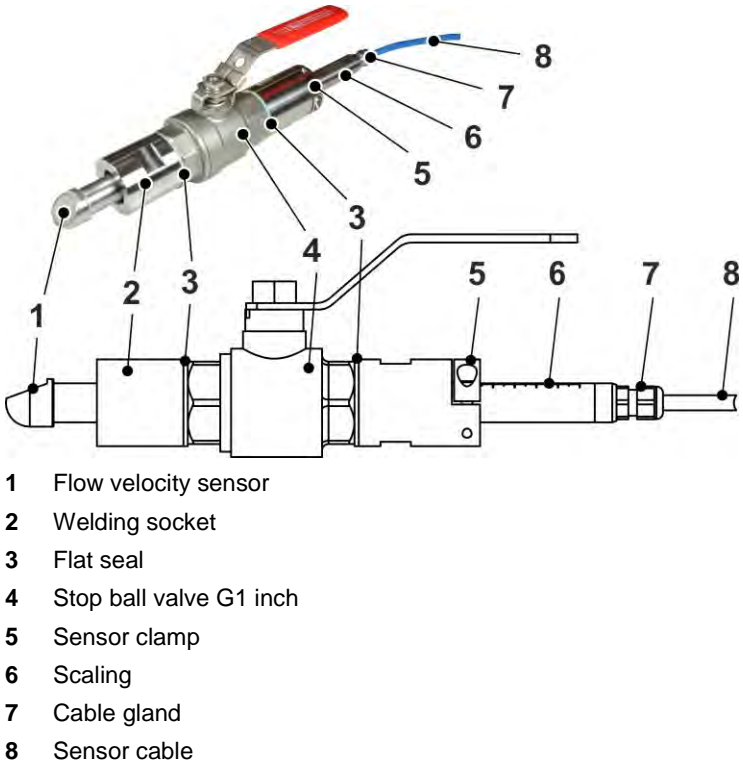

Fig. 4-7 Basic construction sensor CSM-V100R

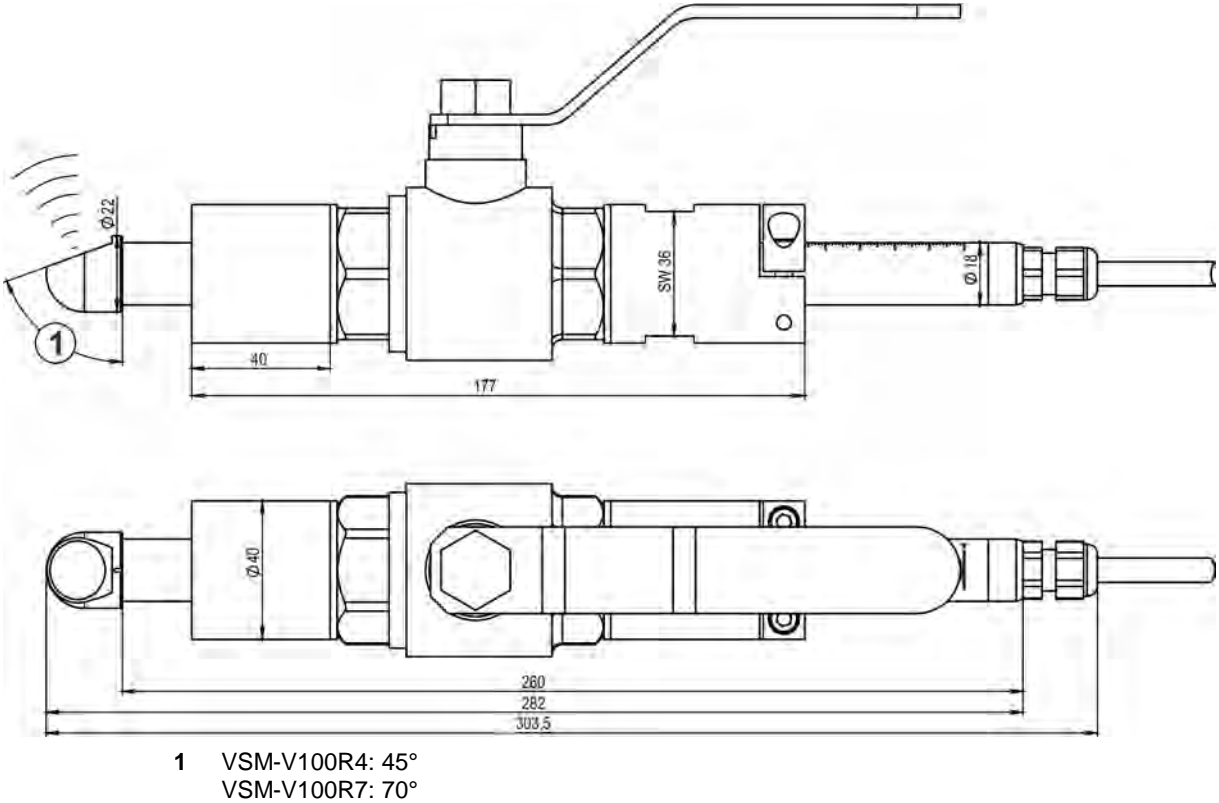
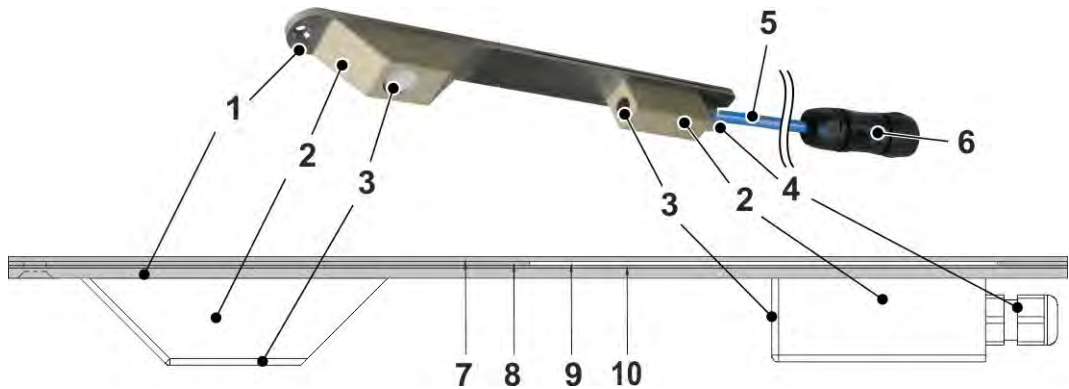

Fig. 4-8 Dimensions sensor CSM-V100R

4.2.4 Sensor DSM



- 1 Mounting plate
- 2 Sensor body
- 3 Sensors for level measurement using air ultrasonic
- 4 Cable gland
- 5 Sensor cable
- 6 Plug with spigot nut
- 7 Cover plate
- 8 Distance plate
- 9 Insertion section for pipe mounting plate
- 10 Intermediate plate

Fig. 4-9 Basic construction sensor DSM

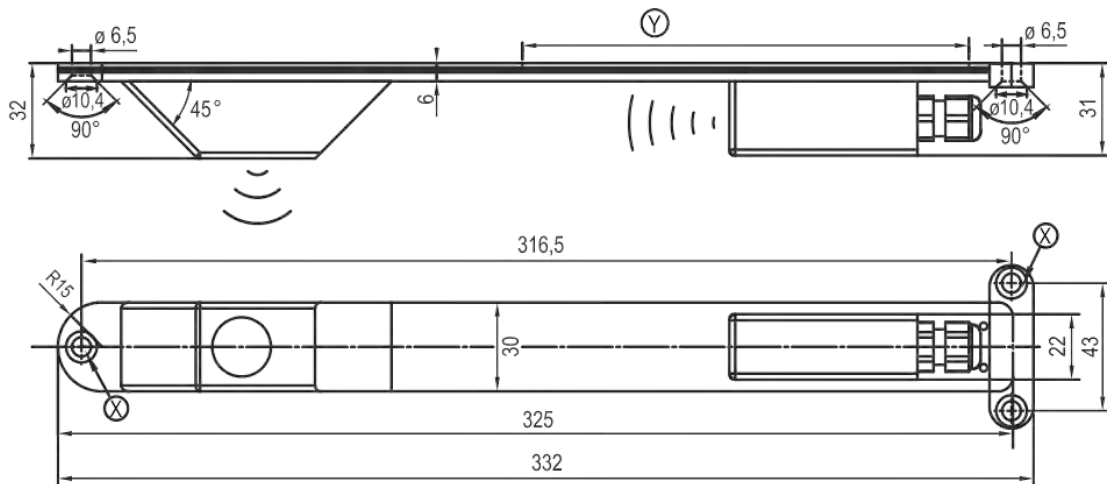

X = Fastening shoe and countersunk hole for direct fastening

Y = Insertion section for pipe mounting plate

Fig. 4-10 Dimensions sensor DSM

4.2.5 Electronic Box EBM

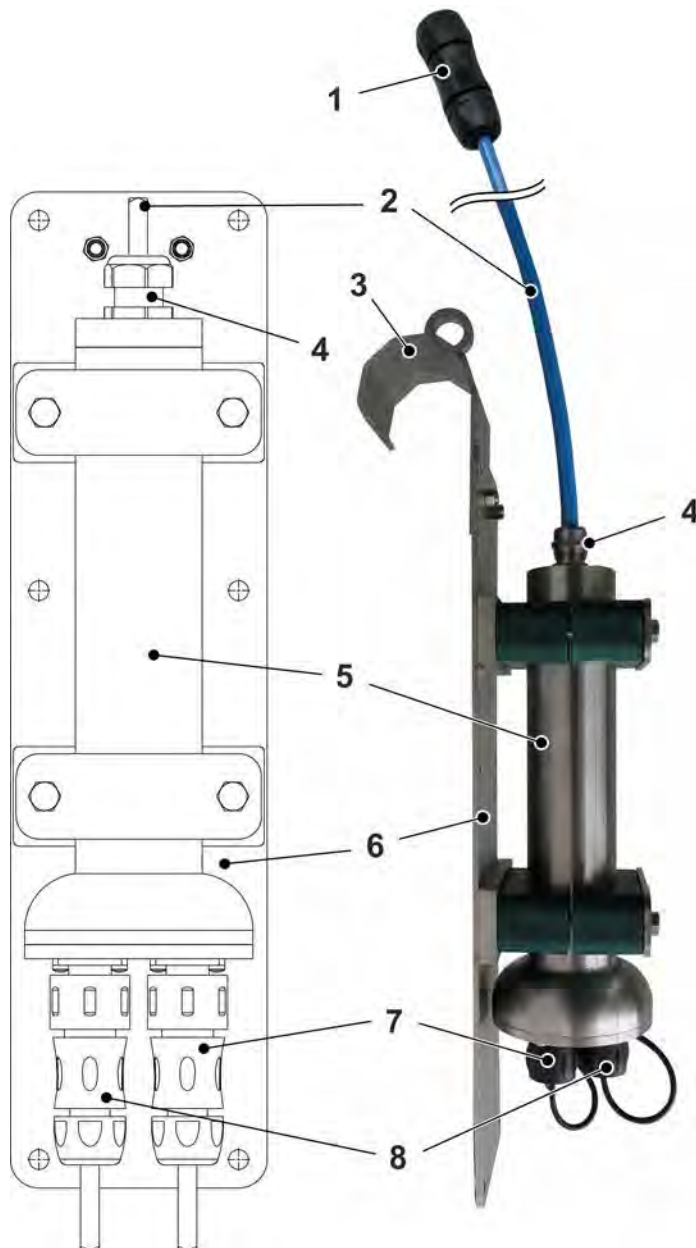

- 1 Plug with spigot nut for connection to PCM Pro or PCM 4 (optional)
- 2 Cable connection to the measurement device NivuFlow 750, NivuFlow 7550, PCM Pro, PCM 4 or OCM Pro CF
- 3 Suspension bracket
- 4 Cable gland
- 5 Electronic body
- 6 Ground plate
- 7 Plug for water-ultrasonic sensor, type CSM
- 8 Plug for air-ultrasonic sensor, type DSM

Fig. 4-11 Basic construction electronic box EBM

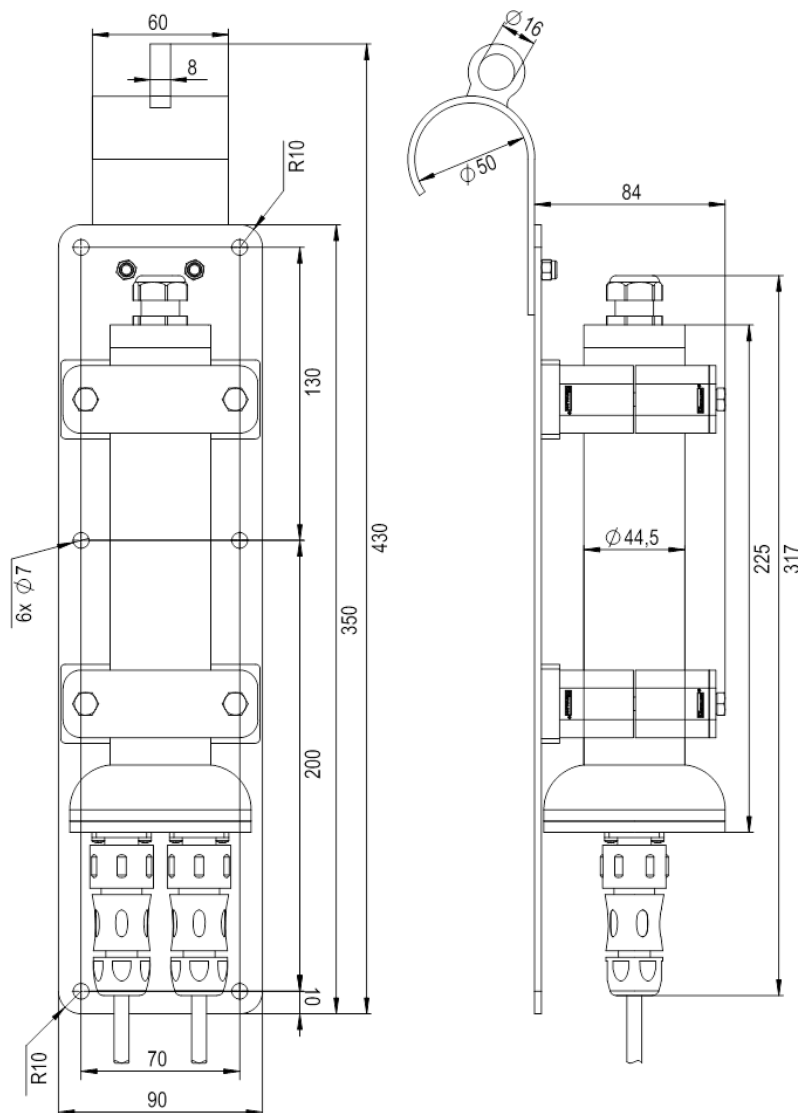
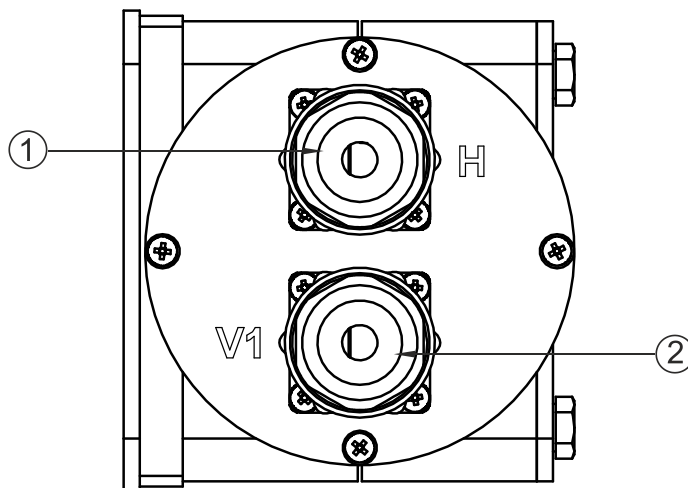

Fig. 4-12 Dimensions Electronic Box EBM



- 1 Socket **H** for air-ultrasonic sensor DSM
- 2 Socket **V1** for flow velocity sensor CSM

Fig. 4-13 Overview socket wiring electronic box EBM



Lock unused sockets

The degree of protection cannot be guaranteed with the sockets unlocked. Disregarding may damage the device.

Each socket is equipped with a cover. Unused sockets must be locked before operation. Keep the sockets of the Electronic Box free of dirt.

Prior to locking the sockets:

1. Clean the sockets with a lint-free cloth.
2. Lock unused connection sockets watertight.

Damaged or possibly lost socket covers can be ordered from NIVUS at extra costs.

4.2.6 Sensor POA-....K

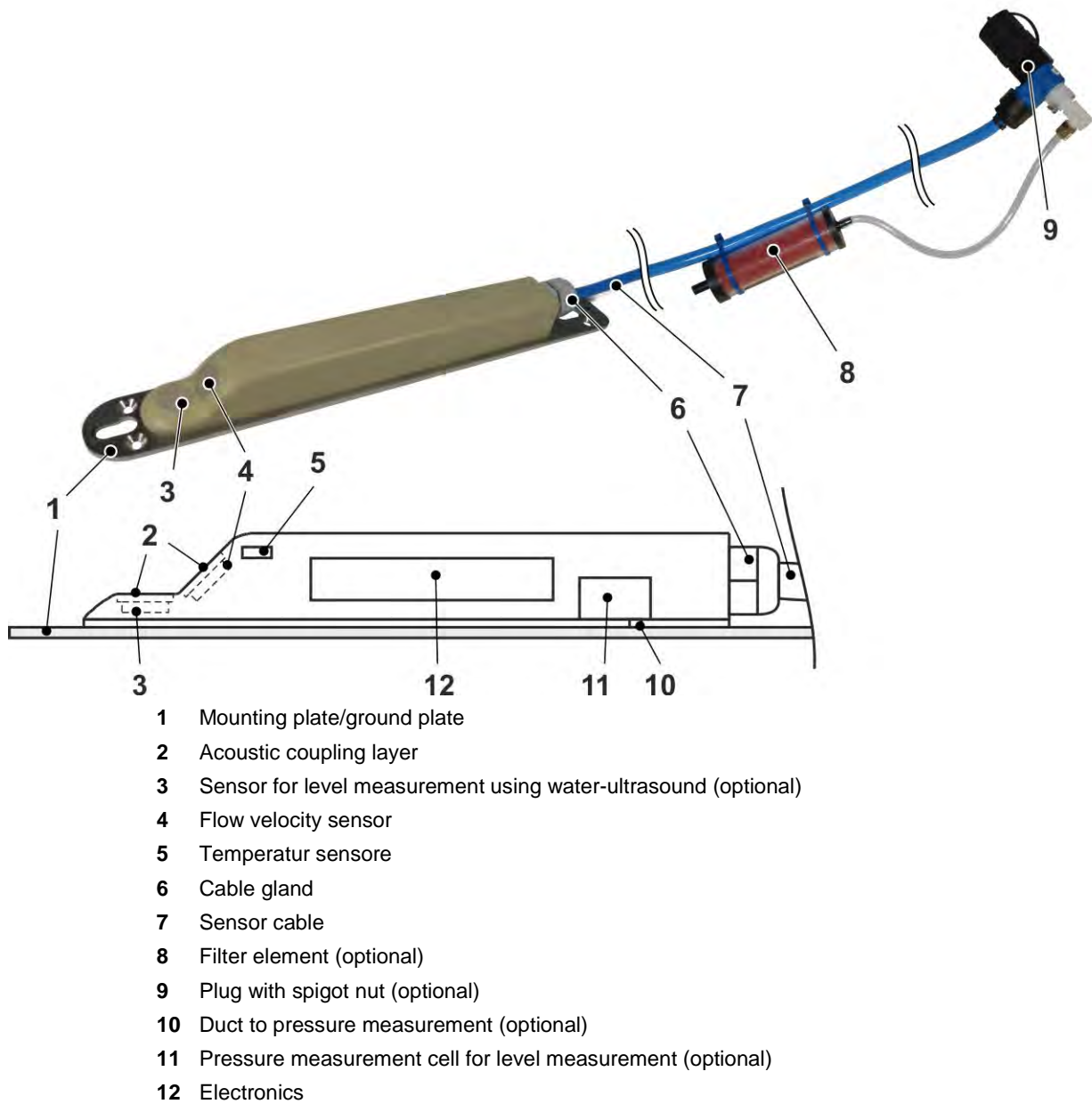
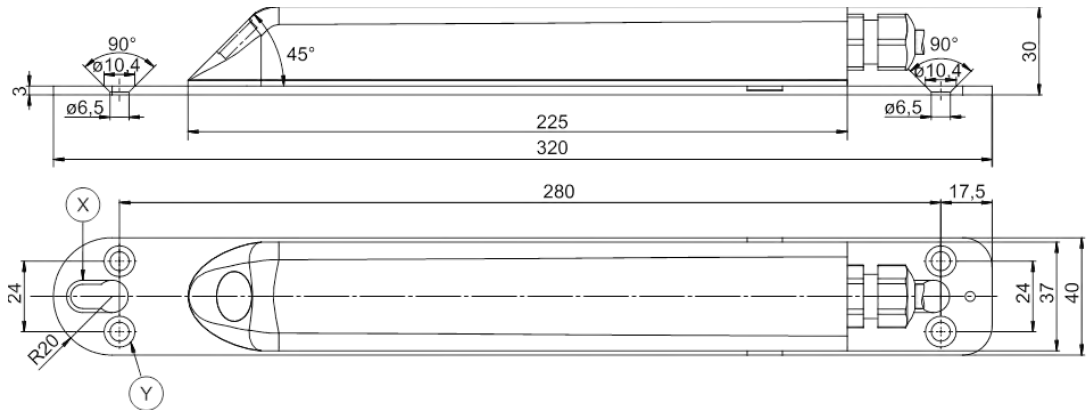
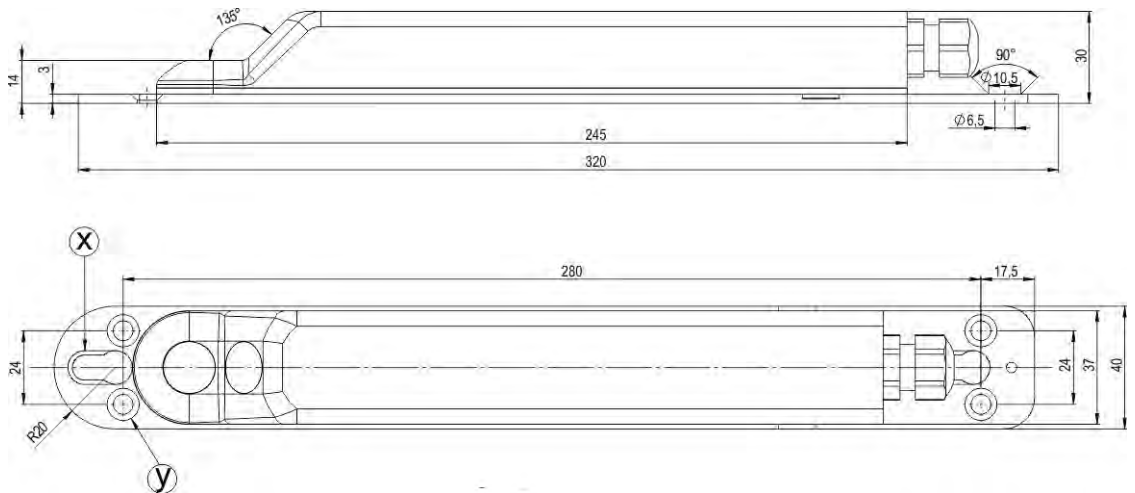

Fig. 4-14 Basic construction sensor POA-....K



X = Slotted holes for fastening on pipe mounting system
 Y = 4 x countersunk holes with $d1 = 6.5$ mm for direct fastening

Fig. 4-15 Dimensions sensor POA-V200K / POA-V2D0K



X = Slotted holes for fastening on pipe mounting system
 Y = 4 x countersunk holes with $d1 = 6.5$ mm for direct fastening

Fig. 4-16 Dimensions sensor POA-V2H1K / POA-V2U1K

4.2.7 Sensor POA-....R

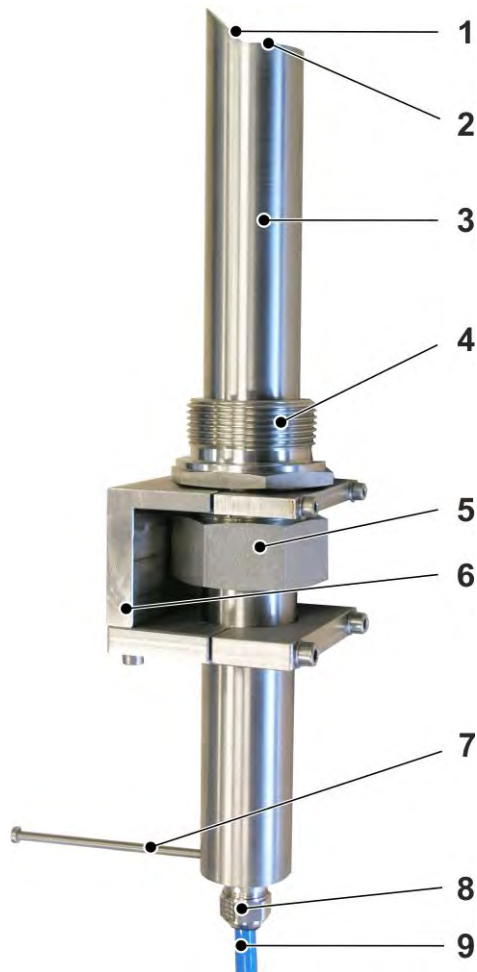

- 1 Flow velocity sensor
- 2 Level sensor (optional)
- 3 Sensor body
- 4 Screw thread G1½
- 5 Union nut, wrench size 50
- 6 Retaining element
- 7 Screw M4, alignment aid - 180° to flow direction
- 8 Cable gland
- 9 Sensor cable

Fig. 4-17 Basic construction sensor POA-....R

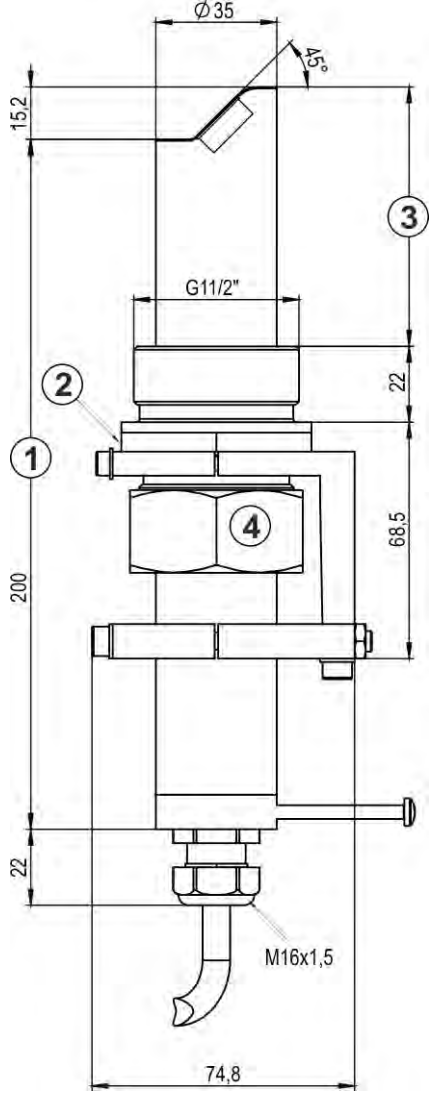

- 1 Minimum length 300 mm for use with stop ball valve
- 2 Wrench size 55
- 3 Movable
- 4 Wrench size 50

Fig. 4-18 Dimensions sensor POA-V200R

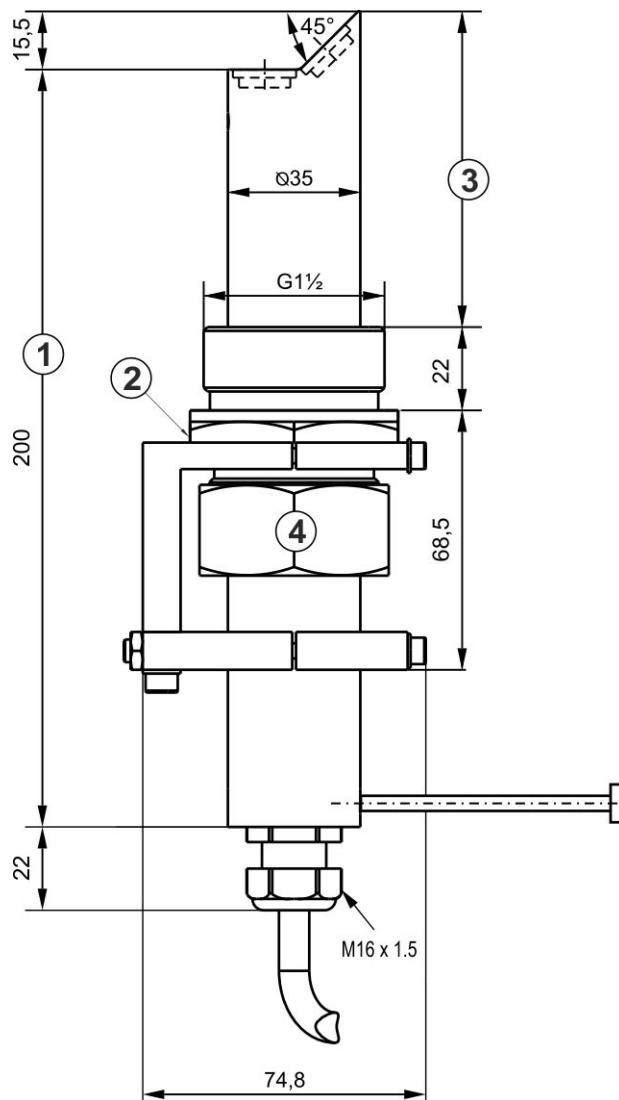

- 1 Minimum length 300 mm for use with stop ball valve
- 2 Wrench size 55
- 3 Movable
- 4 Wrench size 50

Fig. 4-19 Dimensions sensor POA-V2H1R

4.2.8 Sensor OCL

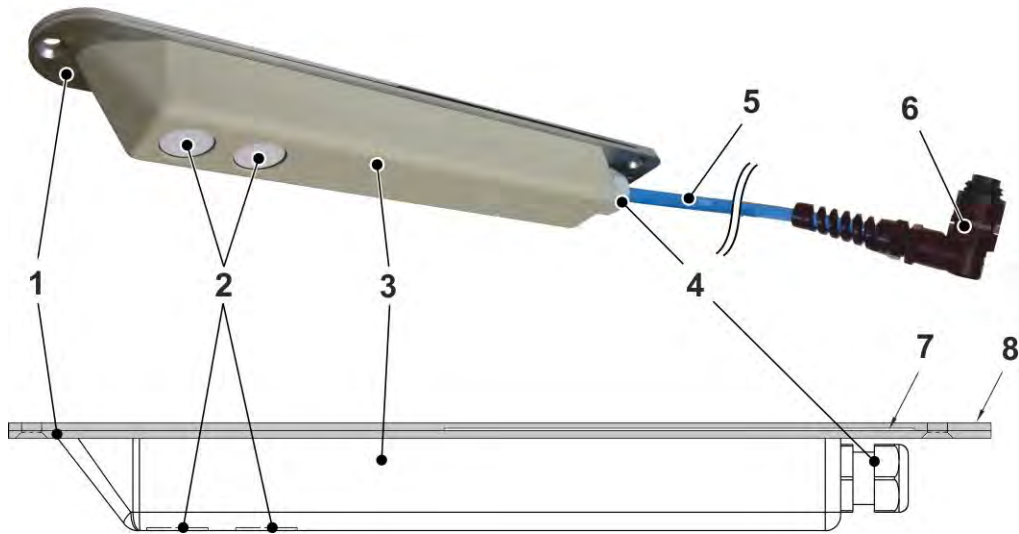

- 1 Mounting plate
- 2 Level sensors
- 3 Sensor body
- 4 Cable gland
- 5 Sensor cable
- 6 Plug with spigot nut
- 7 Insertion section for pipe mounting plate
- 8 Cover plate

Fig. 4-20 Basic construction sensor OCL

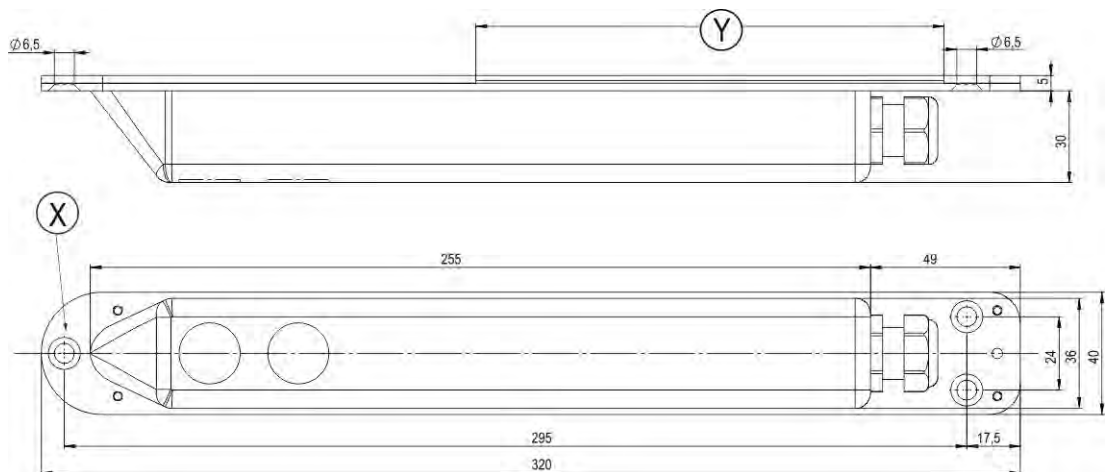

- X = Fastening shoe and countersunk hole for direct fastening
- Y = Insertion section for pipe mounting plate

Fig. 4-21 Dimensions sensor OCL

4.2.9 Sensor CS2-....K

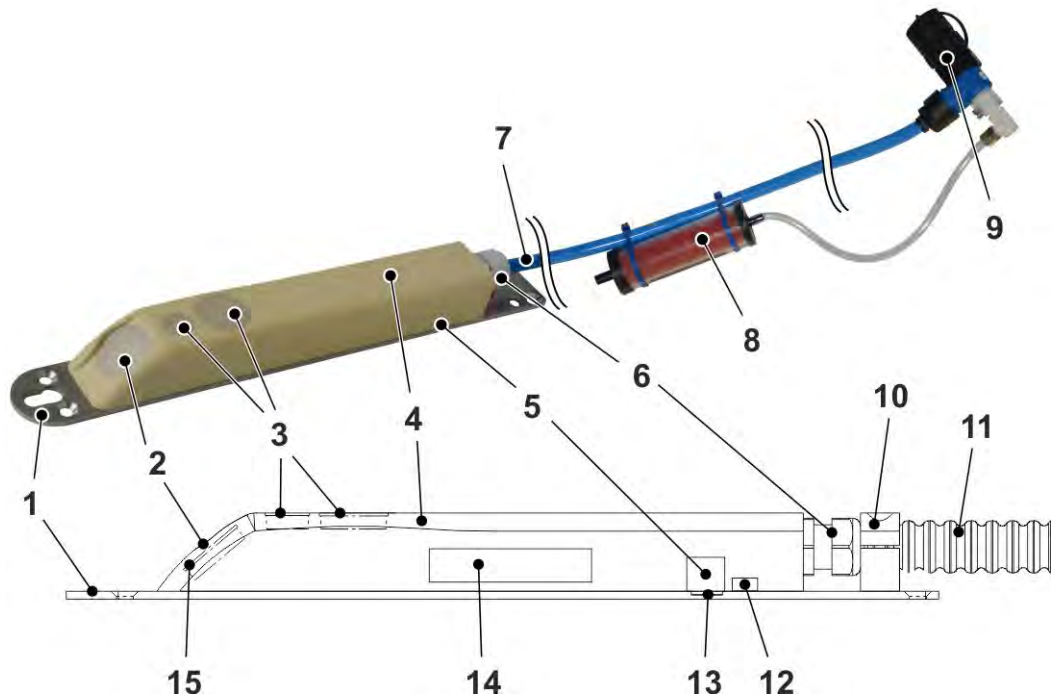

- 1 Ground plate
- 2 Flow velocity sensor
- 3 Level sensor water-ultrasound (optional)
- 4 Sensor body
- 5 Pressure measurement cell for level measurement (optional)
- 6 Cable gland
- 7 Sensor cable
- 8 Filter element (optional)
- 9 Plug with spigot nut (optional)
- 10 Clamp (optional)
- 11 Cable protection hose (optional)
- 12 Temperatur sensor (sensors without pressure cell only)
- 13 Pressure measurement cell (optional)
- 14 Electronics
- 15 Acoustic coupling layer

Fig. 4-22 Basic construction sensor CS2-....K

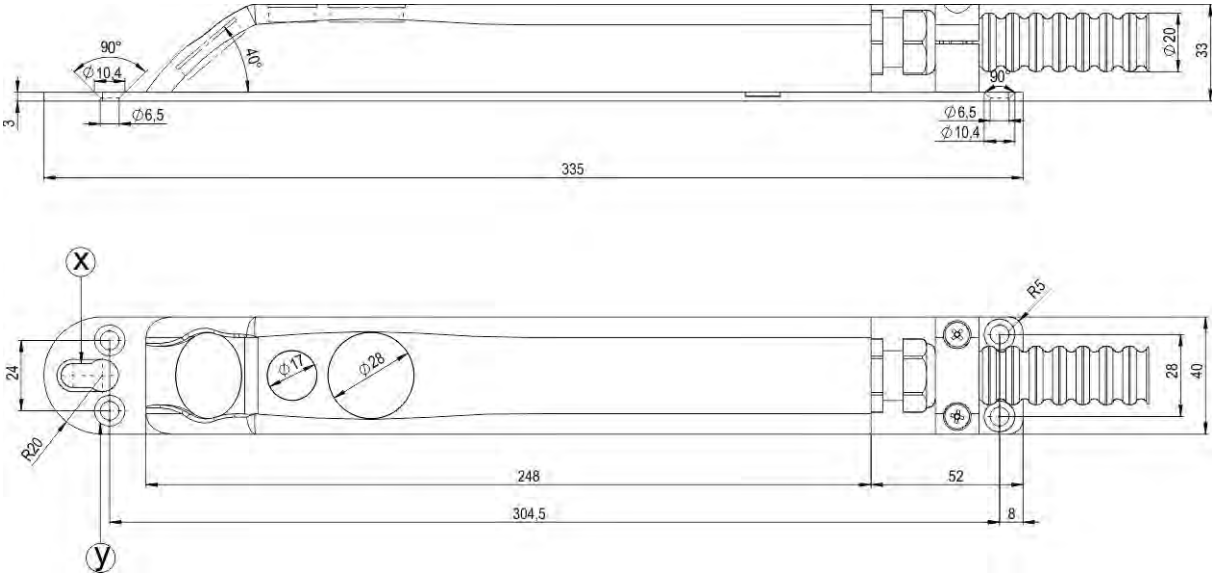

X = Slotted holes for fastening on pipe mounting system
 Y = 4 x countersunk holes with d1 = 6.5 mm, for direct fastening

Fig. 4-23 Dimensions sensor CS2-....K

4.2.10 Sensor CS2-....R

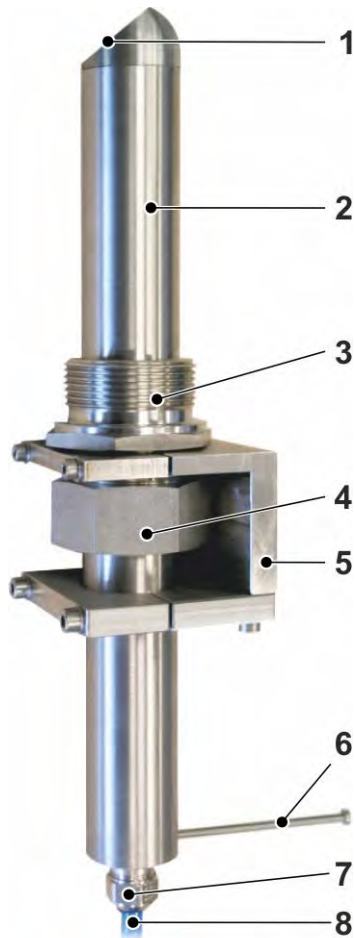

- 1 Flow velocity sensor
- 2 Sensor body
- 3 Screw thread G1½
- 4 Union nut, wrench size 50
- 5 Retaining element
- 6 Screw M4, alignment aid - 180° to flow direction
- 7 Cable gland
- 8 Sensor cable

Fig. 4-24 Basic construction sensor CS2-....R

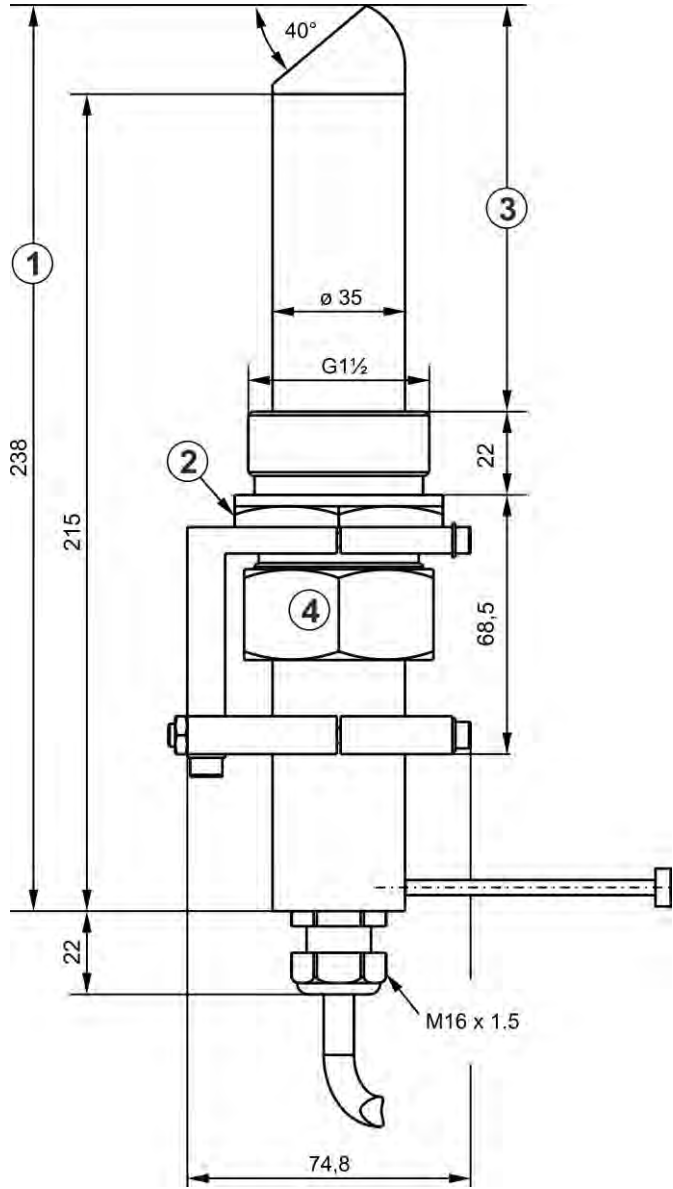

- 1 Minimum length 300 mm for use with stop ball valve
- 2 Wrench size 55
- 3 Movable
- 4 Wrench size 50

Fig. 4-25 Dimensions sensor CS2-....R

4.2.11 Sensor CSP

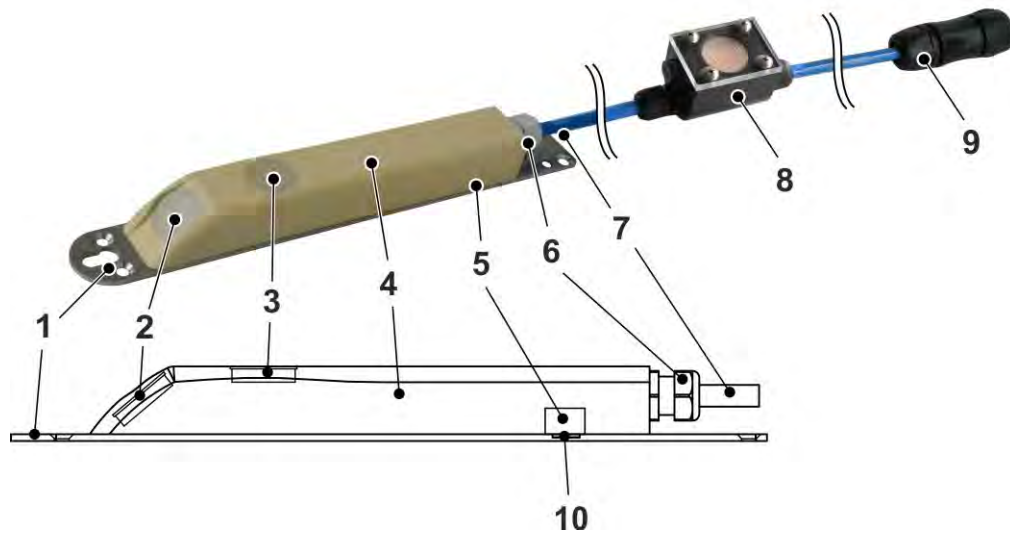

- 1 Ground plate
- 2 Flow velocity sensor
- 3 Sensor for level measurement using water-ultrasound (optional)
- 4 Sensor body
- 5 Pressure measurement cell (optional)
- 6 Cable gland
- 7 Sensor cable
- 8 Pressure compensation element (optional)
- 9 Plug with spigot nut
- 10 Duct to pressure measurement (optional)

Fig. 4-26 Basic construction sensor CSP

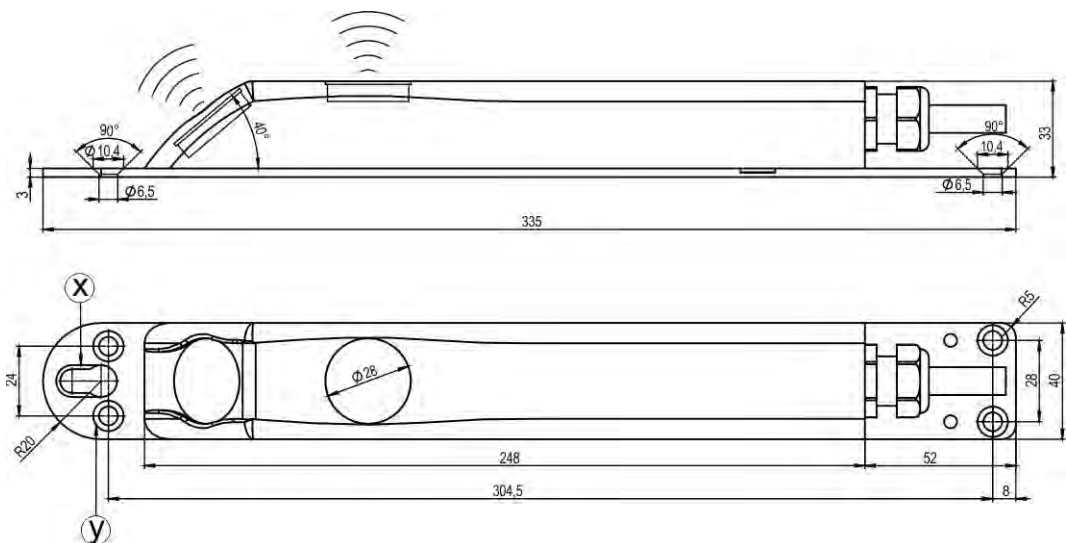

X = Slotted holes for fastening on pipe mounting system

Y = 4 x countersunk holes with $d1 = 6.5$ mm, for direct fastening

Fig. 4-27 Dimensions sensor CSP

4.3 Device identification

The instructions in this manual apply only for the type of sensor or the units depicted on the title page.

The nameplate can be found on the ground plate or the sensor body and contains the following information:

- name and address of manufacturer
- CE label
- type and serial number
- year of manufacture
- Ex label (on Ex-version sensors only) as mentioned in chapter *2.4 Ex-Approval*

In case of enquiries and ordering replacement parts it is important to specify article number as well as the serial number of the respective transmitter or sensor. This ensures correct and quick processing.



Note

- Use the nameplate to verify whether the sensor corresponds with your order.
- Use the nameplate to verify whether the correct control number (ATEX) is specified.

⇒ You can find the EU Declarations of Conformity, the EC-Type-Examination certificates and the IECEx Certificates of Conformity at the end of this manual.

Nameplates



Fig. 4-28 Nameplate sensor CSM-V100K



Fig. 4-29 Nameplate sensor CSM-V1D0K

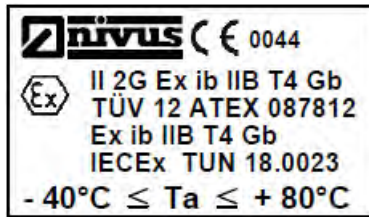

Fig. 4-30 Ex label for sensor CSM

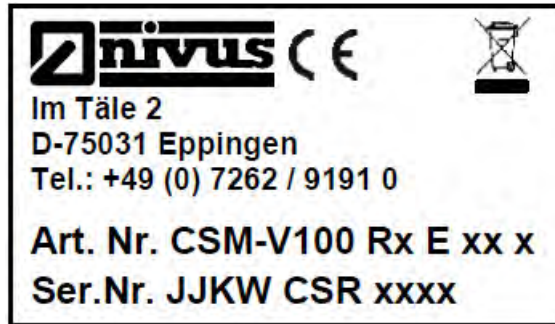

Fig. 4-31 Nameplate sensor CSM-V100R

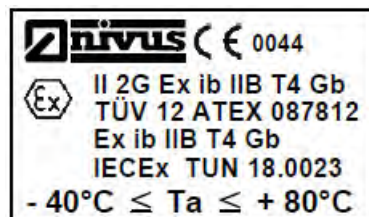

Fig. 4-32 Ex nameplate for pipe sensor, type CSM-V100R

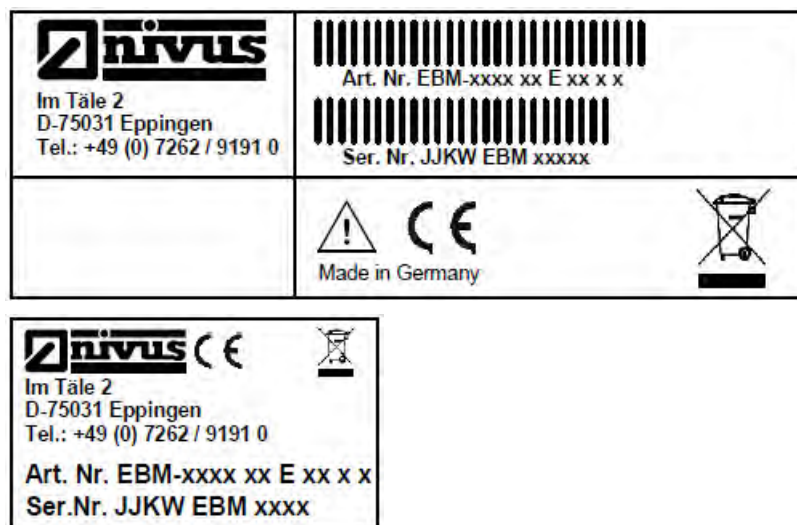

Fig. 4-33 Nameplates Electronic Box, type EBM

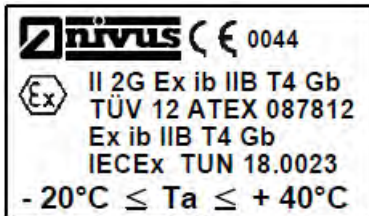
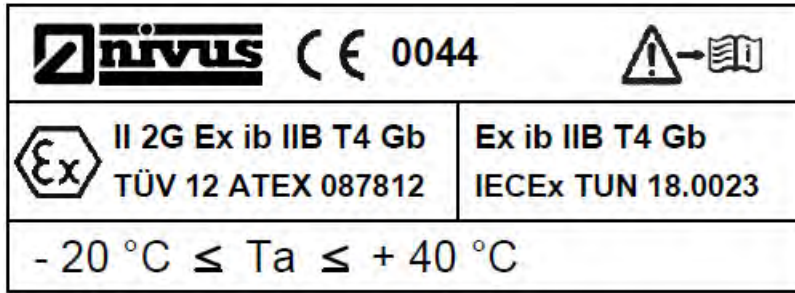

Fig. 4-34 Ex nameplates Electronic Box, type EBM



Fig. 4-35 Nameplate sensor DSM

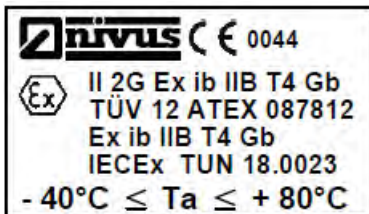

Fig. 4-36 Ex label for sensor DSM



Fig. 4-37 Nameplates sensor CSP

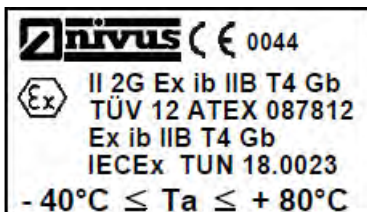
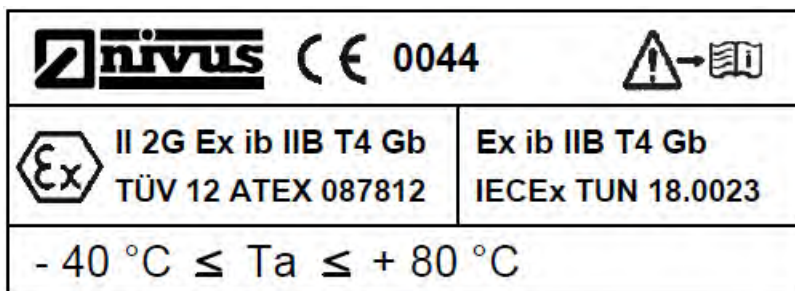

Fig. 4-38 Ex nameplates for sensor CSP



Fig. 4-39 Nameplate sensor POA

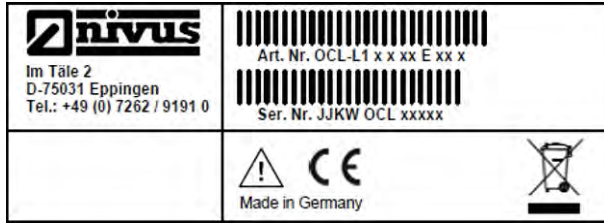

Fig. 4-40 Nameplate sensor OCL

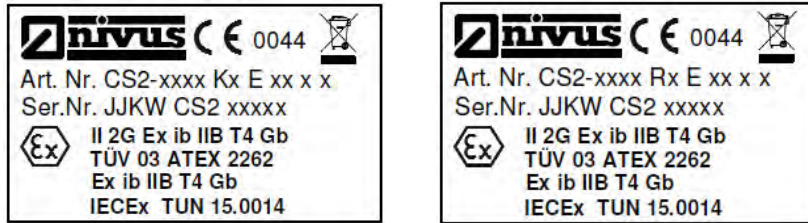

Fig. 4-41 Nameplates sensor CS2



Fig. 4-42 Ex-label for each sensor; type POA, CS2, OCL

4.4 Sensor versions

The sensors are available in various constructions (wedge and pipe sensors) and additionally vary in terms of Ex-Version, cable lengths, sensor connection (cable end for direct connection or configured plug / plug-on filter element) as well as various special versions and materials.

The article number can be found where the cable enters the sensor body as well as on a nameplate on the end of the cable. This nameplate is protected against weathering and abrasion by using a transparent shrunk-on hose.

4.4.1 Type Key for Sensor CSM

CSM-	Sensor with spatial allocation of flow velocities				
	Type				
	V100 without level measurement				
	KT	Wedge sensor made of PVDF; ground plate 1.4571			
	R4	1'' pipe sensor made of stainless steel 1.4571 with PEEK sensor face 45° only for NFM			
	R7	1'' pipe sensor made of stainless steel 1.4571 with PEEK sensor face 70°			
	RX	Pipe sensor, special construction			
	XX	Special construction			
	V1D0 Level measurement with pressure measurement cell				
	KT	Wedge sensor made of PPO; ground plate 1.4571 (until 2018)			
	KN	Wedge sensor made of PPO; ground plate 1.4571 (as of 2018)			
	XX	Special construction			
	Approvals (ATEX)				
	0	none			
	E	Ex-zone 1			
Cable Lengths					
07	7 m				
15	15 m (only type V1D0)				
Sensor Connection					
C	for wedge sensors, connection to electronic box EBM type RD, incl. plug				
D	for wedge sensors, connection to electronic box EBM type RD, incl. pressure compensation element and plug				
E	for pipe sensors, connection to electronic box EBM type RD, incl. plug				
M	for wedge sensors; connection to NFM 750, incl. plug				
P	for wedge sensors; connection to NFM 750, incl. pressure compensation element and plug				
R	for pipe sensors; connection to NFM 750, incl. plug				
CSM-					

4.4.2 Type Key for Sensor DSM

DSM-L0	Air-ultrasonic sensor for non-contact level measurement				
	Construction				
	K	Wedge sensor			
	X	Special construction			
	Sensor Version				
	S	Standard version made of PPO, ground plate 1.4571			
	X	Special construction			
	Transmitting Frequency				
	12	Standard frequency			
	XX	Special construction			
	Approvals (ATEX)				
	0	none			
E	Ex zone 1				
Cable Lengths					
07	7 m				
15	15 m				
Sensor Connection					
B	Connection to electronic box				
M	Connection to NFM 750				
DSM-L0					

4.4.3 Type Key for Electronic Box EBM

EBM-V1L1	Electronic box for connection of 1x CSM and 1x DSM sensor incl. suspension bracket and mounting plate, IP68				
	Construction				
	RD	Standard construction			
	XX	Special construction			
	Approvals (ATEX)				
	0	none			
	E	Ex zone 1 (only in connection with PCM Pro, OCM Pro CF or NF7)			
	Cable Lengths (max. 150 m)				
	03	3 m			
	10	10 m			
	15	15 m			
	20	20 m			
30	30 m				
50	50 m				
99	100 m				
XX	Special length upon request				
Sensor Connection					
S	Connection to PCM Pro and PCM 4				
K	Cable end pre-configured for connection to NF7 and OCM Pro CF				
EBM-V1L1					

4.4.4 Type Key for Sensor POA

POA-	Sensor with special allocation of flow velocities covering a maximum of 16 scan layers
	Type
V200	without level measurement
KT	Wedge sensor made of PPO with PEEK sensor face; ground plate 1.4571
KP	Wedge sensor made of high resistant full PEEK; ground plate 1.4571
KX	Wedge sensor, special construction (e.g. made of high resistant full PEEK with ground plate made of Hastelloy or Titanium)
RT	Pipe sensor made of PPO with PEEK sensor face; pipe body 1.4571
RP	Pipe sensor made of high resistant full PEEK; pipe body 1.4571
RX	Pipe sensor, special construction
V2H1	with ultrasound from bottom up for level measurement
KT	Wedge sensor made of PPO with PEEK sensor face; ground plate 1.4571
KP	Wedge sensor made of high resistant full PEEK; ground plate 1.4571
KX	Wedge sensor, special construction (e.g. made of high resistant full PEEK with ground plate made of Hastelloy or Titanium)
RT	Pipe sensor made of PPO with PEEK sensor face; pipe body 1.4571
RP	Pipe sensor made of high resistant full PEEK; pipe body 1.4571
RX	Pipe sensor, special construction
V2D0	with pressure measurement cell for level measurement
KT	Wedge sensor made of PPO with PEEK sensor face; ground plate 1.4571
KX	Wedge sensor, special construction
V2U1	with pressure measurement cell and ultrasound from bottom up for level measurement
KT	Wedge sensor made of PPO with PEEK sensor face; ground plate 1.4571
KX	Wedge sensor, special construction
	Approvals (ATEX)
0	none
E	Ex zone 1
	Cable Lengths (max 150 m / with pressure cell up to 30 m)
10	10 m
15	15 m
20	20 m
30	30 m
50	50 m
99	99 m
XX	Special length upon request
1B	10 m, FEP coated*
2B	20 m, FEP coated*
3B	30 m, FEP coated*
5B	50 m, FEP coated*
9B	100 m, FEP coated*
XB	Special length / special construction*

							<p>Sensor Connection</p> <p>K for types V20 and V2H: cable end pre-configured for connection to OCM Pro CF; NF7, NFP</p> <p>L for types V2D und V2U: cable end pre-configured for connection to OCM Pro CF; NF7</p> <p>F for types V2D und V2U: connection to PCM Pro and PCM 4, portable version incl. plug and exchangeable filter element</p> <p>S for types V20 and V2H: connection to PCM Pro and PCM 4, portable version incl. plug</p> <p>Pipe Length</p> <p>0 Only for wedge sensor</p> <p>2 20 cm</p> <p>3 30 cm</p> <p>4 40 cm</p> <p>X Special pipe length in dm</p> <p>G 20 cm + extension thread</p>
POA-							

* Cable not possible for types V2D0 and V2U1

4.4.5 Type Key for Sensor OCL

OCL-L1	Active air-ultrasonic sensor						<p>Construction</p> <p>K Wedge sensor</p> <p>X Special construction</p> <p>Sensor Version</p> <p>S Standard version made of PPO, cable :PUR</p> <p>X Special construction</p> <p>Transmitting Frequency</p> <p>12 120 kHz</p> <p>XX Special construction</p> <p>Approvals (ATEX)</p> <p>0 none</p> <p>E Ex zone 1</p> <p>Cable Lengths (max. 150 m)</p> <p>10 10 m</p> <p>15 15 m</p> <p>20 20 m</p> <p>30 30 m</p> <p>50 50 m</p> <p>99 100 m</p> <p>XX Special length upon request</p> <p>Sensor Connection</p> <p>K Cable end pre-configured for connection to OCM Pro CF and NF 750</p> <p>S Connection plug for PCM Pro and PCM 4</p>
OCL-L1							

4.4.6 Type Key for Sensor CS2

CS2-	Correlation sensor für large dimensions				
	Types				
	V100	without level measurement			
		RP	Pipe sensor made of high resistant full PEEK; pipe body 1.4571		
		RX	Pipe sensor, special construction		
		SP	Rod sensor made of high resistant full PEEK; pipe material 1.4571		
	V200	without level measurement			
		KT	Wedge sensor made of PPO with PEEK sensor face; ground plate 1.4571		
	V2H1	with ultrasound from bottom up for level measurement			
		KT	Wedge sensor made of PPO with PEEK sensor face; ground plate 1.4571		
	V2D0	with pressure measurement cell for level measurement			
		KT	Wedge sensor made of PPO with PEEK sensor face; ground plate 1.4571		
	V2U1	with pressure measurement cell and ultrasound from bottom up for level measurement			
		KT	Wedge sensor made of PPO with PEEK sensor face; ground plate 1.4571		
		Approvals (ATEX)			
		0	none		
		E	Ex zone 1		
		Cable Lengths (max 150 m / with pressure cell up to 30 m)			
		10	10 m		
		15	15 m		
		20	20 m		
	30	30 m			
	50	50 m			
	99	99 m			
	XX	Special length upon request			
	Sensor Connection				
	K	For types V20 and V2H: connection to OCM Pro CF and NF7			
	L	for types V2D und V2U: connection to OCM Pro CF and NF7			
	R	for types V100R (pipe sensors): connection to OCM Pro CF and NF7			
	F	for types V2D und V2U: connection to PCM Pro and PCM 4, incl. plug and exchangeable filter element			
	S	for types V20 and V2H: connection to PCM Pro and PCM 4, incl. plug			
	Pipe Length				
	0	only for wedge sensor			
	2	20 cm (standard)			
	3	30 cm			
	4	40 cm			
	X	Special pipe length in dm			
	G	20 cm + extension thread			
CS2-					

4.4.7 Type Key for Sensor CSP

CSP-	Type				
	V200	without level measurement			
	KT	Wedge sensor made of PPO with PEEK sensor face; ground plate 1.4571			
	V2H1	with Ultrasound from bottom up for level measurement			
	KT	Wedge sensor made of PPO with PEEK sensor face; ground plate 1.4571			
	V2D0	with Pressure Measurement Cell for level measurement			
	KT	Wedge sensor made of PPO with PEEK sensor face; ground plate 1.4571			
	V2U1	with Pressure Measurement Cell and ultrasound from bottom up for level measurement			
	KT	Wedge sensor made of PPO with PEEK sensor face; ground plate 1.4571			
		Approvals (ATEX)			
	0	none			
	E	with ATEX approval			
	Cable Length				
	7	7 m			
	15	15 m			
	20	20 m			
	Sensor Connection				
	F	for types V2D0 und V2U1: connection to NFM 750, incl. plug and pressure compensation element			
	S	for types V200 und V2H1:connection to NFM 750, incl. plug			
CSP-					

4.5 Specification

4.5.1 Sensor CSM-V100K

Measurement principle	Correlation with real flow profile measurement
Measurement min.fill level	3 cm
Measurement frequency	1 MHz
Protection	IP68
Ex-Approval (optional)	II 2G Ex ib IIB T4 Gb (Atex) Ex ib IIB T4 Gb (IEC Ex)
Operating temperature	-20 °C to +70 °C (-4 °F to 158 °F) at 15 min. operation time -20 °C to +65 °C (-4 °F to 149 °F) at continuous operation -40 °C to +80 °C (-40 °F to 176 °F) for applications in Ex Zone 1
Storage temperature	-30 °C to +70 °C (-22 °F to 158 °F)
Operating pressure	Max. 4 bar
Cable length	7/15 m, for connection to Electronic Box / NFM 750
Type of cable	LiYC11Y Twinax 2x AWG20/7 + 3x AWG28/7
Outside cable diameter	6 mm +/- 0,2 mm
Medium contacting materials	Polyurethane, PVDF, stainless steel 1.4571, PA
Flow velocity measurement	
Measurement range	-100 cm/s to +600 cm/s
Number of scan layers	Max. 16
Zero point drift	Absolutely stable zero point
Error limits (per scan layer)	< 1% of measurement value (v > 1m/s) < 0.5% of measurement value +5 mm/s (v <1 m/s)
Sonic beam angle	±5 degrees
Beam angle to the horizontal	20°
Temperature measurement	
Measurement range	-40 °C up to +80 °C (-40 °F to 176 °F)
Measurement uncertainty	±0,5 K

4.5.2 Sensor CSM-V1D0K

Measurement principle	Correlation with real flow profile measurement
Measurement min.fill level	5.5 cm
Measurement frequency	1 MHz
Protection	IP68
Ex-Approval (optional)	II 2G Ex ib IIB T4 Gb (ATEX) Ex ib IIB T4 Gb (IEC Ex)
Operating temperature	-20 °C to +50 °C (-4 °F to 122 °F) -40 °C to +80 °C (-40 °F to 176 °F) for applications in Ex Zone 1
Storage temperature	-30 °C to +70 °C (-22 °F to 158 °F)
Operating pressure	Max. 1 bar
Cable length	7/15 m, for connection to Electronic Box / NFM 750
Type of cable	LiYC11Y 1x (2x AWG24/7 CAT 7) + PA 1,5/2,5mm + (4x AWG26/7)
Outside cable diameter	9 mm +/- 0,25 mm
Medium contacting materials	Polyurethane, stainless steel 1.4571, PPO GF30, PA, Pressure compensation element: POM-C, PMMA, PA, stain- less steel 1.4571
Flow velocity measurement	
Measurement range	-100 cm/s to +600 cm/s
Number of scan layers	Max. 16
Zero point drift	Absolutely stable zero point
Error limits (per scan layer)	< 1% of measurement value (v > 1m/s) < 0.5% of measurement value +5 mm/s (v <1 m/s)
Sonic beam angle	±5 degrees
Beam angle to the horizontal	35°
Level measurement - Pressure	
Measurement range	0 to 500 cm
Zero point drift	Max. 0.75% of final value (0–50 °C)
Measurement uncertainty	≤ 0.5% of final value
Temperature measurement	
Measurement range	-40 °C up to +80 °C (-40 °F to 176 °F)
Measurement uncertainty	±0,5 K

4.5.3 Sensor CSM-V100R

Measurement principle	Correlation with real flow profile measurement
Measurement frequency	1 MHz
Protection	IP68
Ex-Approval (optional)	II 2G Ex ib IIB T4 Gb (ATEX) Ex ib IIB T4 Gb (IECEX)
Operating temperature	-40 °C to +80 °C (-40 °F to 176 °F) -40 °C to +80 °C (-40 °F to 176 °F) for applications in Ex Zone 1
Storage temperature	-30 °C to +70 °C (-22 °F to 158 °F)
Operating pressure	max. 16 bar
Cable length	7/15 m
Type of cable	LiYC11Y Twinax 2x AWG20/7 + 3x AWG28/7
Outside cable diameter	6 mm ±0.2 mm
Types of construction	Pipe sensor for installation in pipes with sensor screw joint and retaining element
Medium contacting materials	Polyurethane, stainless steel 1.4571, PEEK, o-ring made of NBR
Measurement range	-100 cm/s to +600 cm/s
Number of scans	Max. 16
Zero point drift	Absolutely stable zero point
Error limits (per scan layer)	< 1% of measurement value (v > 1m/s) < 0.5% of measurement value +5 mm/s (v <1 m/s)
Minimum filling level	3,0 cm
Sonic beam angle	±5 degrees
Beam angle to the horizontal	CSM-V100R7: 20° CSM-V100R4: 45°

4.5.4 Sensor DSM

Measurement principle	Ultrasonic transit time
Measurement frequency	125 kHz / 200 kHz
Protection rating	IP68
Ex-Approval	II 2G Ex ib IIB T4 Gb (ATEX), Ex ib IIB T4 Gb (IEC Ex)
Operating temperature	-20 °C to +80 °C (-4 °F to 176 °F) -40 °C to +80 °C (-40 °F to 176 °F) for applications in Ex Zone 1
Storage temperature	-30 °C to +70° C (-22 °F to 158 °F)
Operating pressure	max. 1 bar
Cable length	7/15 m for connection to Electronic Box / NFM 750
Type of cable	LiYC11Y 2x (2x28 AWG/7-(ST)12Y)+4x28 AWG/7
Outside cable diameter	6,7 mm +/- 0,25 mm
Medium contacting materials	Polyurethane, stainless steel 1.4571, PPO GF30, PA
Level measurement	
Measurement range	0 to 200 cm (0 to 6.56 ft)
Dead zone (as from ground plate)	4 cm (1.57 in)
Measurement uncertainty	< ±5 mm
Temperature measurement	
Measurement range	-40 °C to +80 °C (-40 °F to 176 °F)
Measurement uncertainty	±0.5 K

4.5.5 Electronic Box EBM

Protection rating	IP68 (with connection sockets locked)
Ex-Approval	II 2G Ex ib IIB T4 Gb (Atex), Ex ib IIB T4 Gb (IEC Ex)
Operating temperature	-20 °C to +50 °C (-4 °F to 122 °F) -20 °C to +40 °C (-4 °F to 104 °F) for applications in Ex Zone 1
Storage temperature	-30 °C to +70 °C (-22 °F to 158 °F)
Operating pressure	Max. 1 bar
Cable length	3/10/20/30/50/100 m
Type of cable	LiYC11Y 2x1.5 + 1x2x0.34
Outside cable diameter	8.4 mm ±0.25 mm
Medium contacting materials	Polyurethane, stainless steel 1.4571, PP

4.5.6 Sensor POA

Measurement principle	<ul style="list-style-type: none"> - Ultrasonic transit time (level) - Piezo-resistive pressure measurement (level) - Correlation with real flow profile measurement
Measurement frequency	1 MHz
Protection	IP68
Ex-Approval (optional)	II 2G Ex ib IIB T4 Gb (ATEX) Ex ib IIB T4 Gb (IECEX)
Operating temperature	-20 °C to +50 °C (-4 °F to 122 °F) -20 °C to +40 °C (-4 °F to 104 °F) for applications in Ex Zone 1
Storage temperature	-30 °C to +70 °C (-22 °F to 158 °F)
Operating pressure	Max. 4 bar (combi sensor with pressure element max. 1 bar)
Cable length	10/15/20/30/50/100 m for sensors without plug (sensor connection type "K" and "L") extendable up to 250 m max. (820 ft). Using sensors with integrated pressure measurement cell (Level measurement, type V2D0 und V2U1) requires to use a pressure compensation element after a cable length of 30 m (99 ft). Element may also be used to connect extension.
Type of cable	<ul style="list-style-type: none"> - Combi sensors with pressure measurement: LiYC11Y 2x1.5 + 1x2x0.34 + PA 1.5/2.5 - Sensors without pressure measurement: LiYC11Y 2x1.5 + 1x2x0.34
Outside cable diameter	<ul style="list-style-type: none"> - Combi sensors with pressure measurement: 9.75 mm ±0.25 mm - Sensors without pressure measurement: 8.40 mm ±0.25 mm
Sensor types	<ul style="list-style-type: none"> - Flow velocity sensor with v-measurement using cross correlation and temperature measurement to compensate the temperature effect on the velocity of sound. - Combi sensor with flow velocity sensor using cross correlation, level measurement via water ultrasonic and temperature measurement to compensate the temperature effect on the velocity of sound. - Combi sensor with flow velocity sensor using cross correlation, level measurement via pressure and temperature measurement to compensate the temperature effect on the velocity of sound (wedge sensor only). - Combi sensor with flow velocity sensor using cross correlation, level measurement via water ultrasonic as well as redundant pressure measurement and temperature measurement to compensate the temperature effect on the velocity of sound (wedge sensor only).
Types of construction	<ul style="list-style-type: none"> - Wedge sensor for installation on channel bottom - Pipe sensor for installation in pipes with sensor screw joint and retaining element or for installation in floats
Medium contacting materials	Polyurethane, stainless steel 1.4571, PPO GF30, PA (wedge sensor only), PTFE (pipe sensors only) Option: sensor made of PEEK, resistant against chemical substances, Hastelloy® C-276 mounting plate, Titanium mounting plate, FEP coated cable

Flow velocity measurement	
Measurement range	-100 cm/s to +600 cm/s
Number of scans	Max. 16
Zero point drift	Absolutely stable zero point
Error limits (per scan layer)	< 1% of measurement value ($v > 1\text{ m/s}$) < 0.5% of measurement value +5 mm/s ($v < 1\text{ m/s}$)
Minimum filling level	6,5 cm
Sonic beam angle	± 5 degrees
Beam angle to the horizontal	45°
Level measurement – Water ultrasonic	
Measurement range	0 to 200 cm (0 to 6.56 ft); lowest absolutely measurable level 5 cm (0.164 ft)
Zero point drift	Absolutely stable zero point
Measurement uncertainty	< ± 2 mm
Level measurement - Pressure	
Measurement range	0 to 500 cm
Zero point drift	Max. 0.75% of final value (0–50 °C)
Measurement uncertainty	$\leq 0.5\%$ of final value
Temperature measurement	
Measurement range	-20 °C to +50 °C (-4 °F to 122 °F)
Measurement uncertainty	± 0.5 K

4.5.7 Sensor OCL

Measurement principle	Ultrasonic transit time
Measurement frequency	120 kHz
Protection rating	IP68
Ex-Approval	II 2G Ex ib IIB T4 Gb (ATEX) Ex ib IIB T4 Gb (IECEX)
Operating temperature	-20 °C to +50 °C (-4 °F to 122 °F) -20 °C to +40 °C (-4 °F to 104 °F) for applications in Ex Zone 1
Storage temperature	-30 °C to +70 °C (-22 °F to 158 °F)
Operating pressure	Max. 1 bar
Cable length	10/15/20/30/50/100 m
Type of cable	LiYC11Y 2x1.5 + 1x2x0.34
Outside cable diameter	8.4 mm ± 0.25 mm
Type of construction	Wedge sensor for installation in channel vertex
Medium contacting materials	Polyurethane, stainless steel 1.4571, PPO GF30, PA
Level measurement	
Measurement range	To 200 cm (to 6.56 ft)
Dead zone (as from ground plate)	14 cm (5.51 in)
Measurement uncertainty	< $\pm 0.5\%$ of final value
Temperature measurement	
Measurement range	-20 °C to +50 °C (-4 °F to 122 °F)
Measurement uncertainty	± 0.5 K

4.5.8 Sensor CS2

Measurement principle	<ul style="list-style-type: none"> - Ultrasonic transit time (level) - Piezo-resistive pressure measurement (level) - Correlation with digital pattern detection (flow velocity)
Measurement frequency	1 MHz
Protection	IP68
Ex-Approval (optional)	II 2G Ex ib IIB T4 Gb (ATEX) Ex ib IIB T4 Gb (IECEX)
Operating temperature	-20 °C to +50 °C (-4 °F to 122 °F) -20 °C to +40 °C (-4 °F to 104 °F) for applications in Ex Zone 1
Storage temperature	-30 °C to +70 °C (-22 °F to 158 °F)
Operating pressure	max. 4 bar (combi sensor with pressure element max. 1 bar)
Cable length	10/15/20/30/50/100 m for sensors without plug (sensor connection type "K" and "L") extendable up to 250 m max. (820 ft). Using sensors with integrated pressure measurement cell (level measurement, type V2D0 und V2U1) requires to use a pressure compensation element after a cable length of 30 m (99 ft). Element may also be used to connect extension.
Type of cable	<ul style="list-style-type: none"> - Combi sensors with pressure measurement: LiYC11Y 2x1,5 + 1x2x0,34 + PA 1,5/2,5 - Sensors without pressure measurement: LiYC11Y 2x1,5 + 1x2x0,34
Outside cable diameter	<ul style="list-style-type: none"> - Combi sensors with pressure measurement: 9.75 mm ±0.25 mm - Sensors without pressure measurement: 8.4 mm ±0.25 mm
Sensor types	<ul style="list-style-type: none"> - Flow velocity sensor with v-measurement using cross correlation and temperature measurement to compensate the temperature effect on the velocity of sound. - Combi sensor with flow velocity sensor using cross correlation, level measurement via water ultrasonic and temperature measurement to compensate the temperature effect on the velocity of sound. - Combi sensor with flow velocity sensor using cross correlation, level measurement via pressure and temperature measurement to compensate the temperature effect on the velocity of sound (only for wedge sensors). - Combi sensor with flow velocity sensor using cross correlation, level measurement via water ultrasonic as well as redundant pressure measurement and temperature measurement to compensate the temperature effect on the velocity of sound (only for wedge sensors).
Types of construction	<ul style="list-style-type: none"> - Wedge sensor for installation on channel bottom or channel wall - Pipe sensor for installation in pipes with sensor screw joint and retaining element
Medium contacting materials	Polyurethane, stainless steel 1.4571, PPO GF30, PEEK, PA6

Flow velocity measurement	
Measurement range	-100 cm/s to +600 cm/s (-3.28 fps to 19.7 fps)
Number of scans	Max. 16
Zero point drift	Absolutely stable zero point
Error limits (per scan layer)	< 1% of measurement value ($v > 1\text{ m/s}$) < 0.5% of measurement value +5 mm/s ($v < 1\text{ m/s}$)
Minimum filling level	8,0 cm
Sonic beam angle	± 5 degrees
Beam angle to the horizontal	50°
Level measurement – Water ultrasonic	
Measurement range	0 to 500 cm (0 to 16.4 ft), lowest absolutely measurable level 8 cm (0.26 ft) (only for wedge sensors)
Measurement uncertainty	< ± 2 mm
Level measurement – Pressure	
Measurement range	0 to 500 cm
Zero point drift	max. 0.75% of final value (0–50 °C)
Measurement uncertainty	$\leq 0.5\%$ of final value
Temperature measurement	
Measurement range	-20 °C to +50 °C
Measurement uncertainty	± 0.5 K

4.5.9 Sensor CSP

Measurement principle	<ul style="list-style-type: none"> - Ultrasonic transit time (level) - Piezo-resistive pressure measurement (level) - Correlation with digital pattern detection (flow velocity)
Measurement frequency	1 MHz
Protection	IP68
Ex-Approval (optional)	II 2G Ex ib IIB T4 Gb (ATEX) Ex ib IIB T4 Gb (IECEX)
Operating temperature	-40 °C to +80 °C (-40 °F to 176 °F) -40 °C to +80 °C (-40 °F to 176 °F) for applications in Ex Zone 1
Storage temperature	-30 °C to +70 °C (-22 °F to 158 °F)
Operating pressure	Max. 4 bar (combi sensor with pressure element max. 1 bar)
Cable length	7/15/20 m Sensors with integrated pressure measurement cell (level measurement, type V2D0 und V2U1) ist are equipped with a pressure compensation element after 14 m / 19 m (45.93 ft / 62.34 ft).
Type of cable	Combi sensors with/without pressure measurement: LiYC11Y 2x(2x AWG24/7-CAT7) + PA 1,5/2,5 + (4x AWG26/7)
Outside cable diameter	Combi sensors with/without pressure measurement: 9.7 mm ± 0.2 mm

Sensor types	<ul style="list-style-type: none"> - Flow velocity sensor with v-measurement using cross correlation and temperature measurement to compensate the temperature effect on the velocity of sound. - Combi sensor with flow velocity sensor using cross correlation, level measurement via water ultrasonic and temperature measurement to compensate the temperature effect on the velocity of sound. - Combi sensor with flow velocity sensor using cross correlation, level measurement via pressure and temperature measurement to compensate the temperature effect on the velocity of sound (only for wedge sensors). - Combi sensor with flow velocity sensor using cross correlation, level measurement via water ultrasonic as well as redundant pressure measurement and temperature measurement to compensate the temperature effect on the velocity of sound (only for wedge sensors).
Types of construction	- Wedge sensor for installation on channel bottom or channel wall
Medium contacting materials	Polyurethane, stainless steel 1.4571, PPO GF30, PEEK, PA6
Flow velocity measurement	
Measurement range	-100 cm/s to +600 cm/s (-3.28 fps to 19.7 fps)
Number of scans	Max. 16
Zero point drift	Absolutely stable zero point
Error limits (per scan layer)	< 1% of measurement value ($v > 1\text{ m/s}$) < 0.5% of measurement value +5 mm/s ($v < 1\text{ m/s}$)
Minimum filling level	8 cm
Sonic beam angle	± 5 degrees
Beam angle to the horizontal	50°
Level measurement – Water ultrasonic	
Measurement range	0 to 500 cm (0 to 16.4 ft), lowest absolutely measurable level 8 cm (0.26 ft)
Measurement uncertainty	< ± 2 mm
Level measurement - Pressure	
Measurement range	0 to 500 cm
Zero point drift	Max. 0.75% of final value (0–50 °C)
Measurement uncertainty	$\leq 0.5\%$ of final value
Temperature measurement	
Measurement range	-40 °C to +80 °C (-40 °F to 176 °F)
Measurement uncertainty	± 0.5 K

5 Installation

WARNING***Check for explosive atmosphere using a gas warner***

When connecting the sensor to the transmitter the metal sensor ground plate must not exceed 1 GΩ grounding resistance!

In this case make sure to eliminate the risk of explosive atmospheres by using a gas warning unit prior to installation or maintenance works. Please observe to avoid building up electrostatic energy during the works!

5.1 Installation Instructions

During installation observe the hints below relating to ESD and mounting place.

- Observe appropriate installation.
- Follow applicable legal or operational guidelines.

Inappropriate use may result in injuries and/or damage on instruments!

***Important Note***

Observe the following hints on how to avoid electrostatic discharge (ESD).

The sensitive electronic components inside the sensor may get damaged by static electricity. The manufacturer recommends the following steps to prevent the device from getting damaged due to electrostatic discharge:

- Discharge static electricity from your body before touching the instrument's electronic components.
- Avoid unnecessary movements to reduce the risk of building up static electricity.

5.1.1 Electrical Installation

WARNING***Disconnect the unit from mains power***

All work on electrical connections may only be carried out with the supply voltage turned off.

Observe electrical data specified on the nameplate.

For electric installation the regulations in the respective countries must be referred to.

5.1.2 Notes on Sensor Installation



Leakage due to removing components

Removing or loosening from ground plate or cable gland result in leakage and therefore will cause measurement and sensor failure.

*Do absolutely **not remove any parts** of the sensor! Otherwise warranty as well as Ex protection will expire!*

The installation of the sensors is described in the separately *Installation Instruction Correlation and Doppler Sensors*.

Please refer to:

- selecting sensor positions
- required calming sections
- sensor installation and fastening
- cable layout

Please anyway observe the hints on sensors with integrated pressure cell in this manual (chapter *5.5 Pressure compensation elements*).

5.2 Mounting the protection hose for the sensors CS2 and CSP

It is possible to optionally install a cable protection hose on the sensor. The following accessories are required:

- 1 cable protection hose with a length of 0.5 m / 1.0 m / 3.0 m
- 1 clamp
- 4 screws

These accessories are available on request.

Procedure:

1. Fasten the bottom part of the clamp on the ground plate by using 2 screws

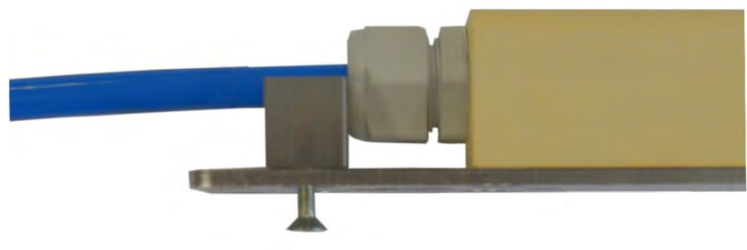

2. Pull the cable protection hose over the sensor cable and put it into the clamp

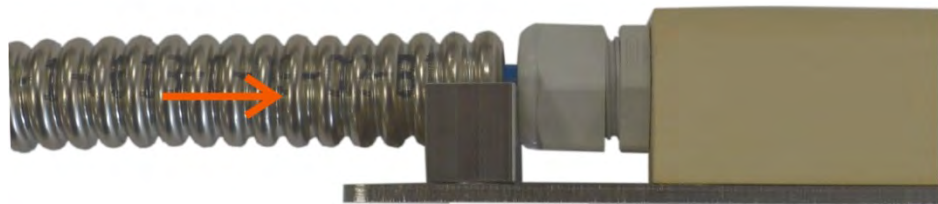

3. Put on the top part of the clamp and fasten it

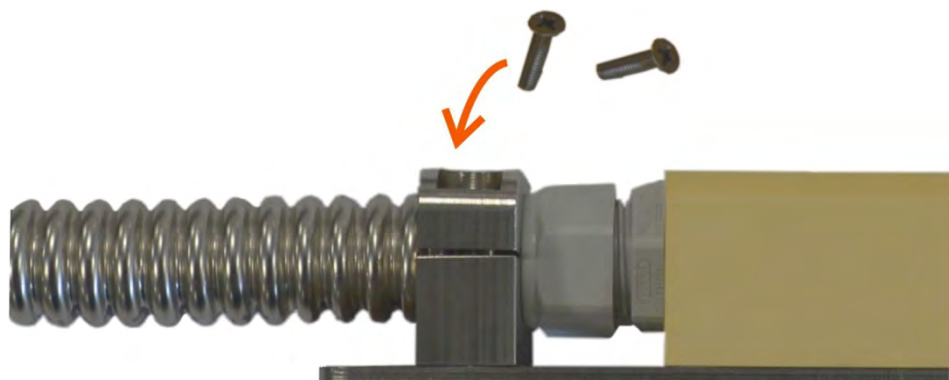

5.3 Plug wiring and Sensor Cable

5.3.1 Sensors CSM and CSP

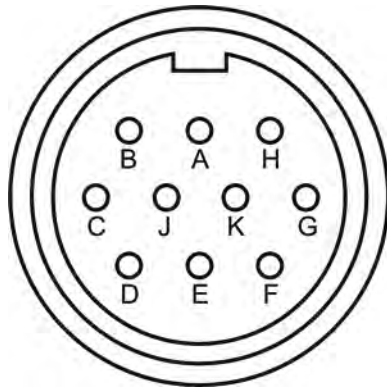

- A Piezo V1 +
- B Piezo V1 -
- C Piezo V2 +
- D Piezo V2 -
- E Pressure_Temp._GND
- F Temp.-Signal_WUS
- G Pressure_RxTx -
- H Pressure_RxTx +
- J Pressure_Temp._WUS_V +
- K Cable shield

Fig. 5-1 Plug wiring sensor CSM; connection to EBM

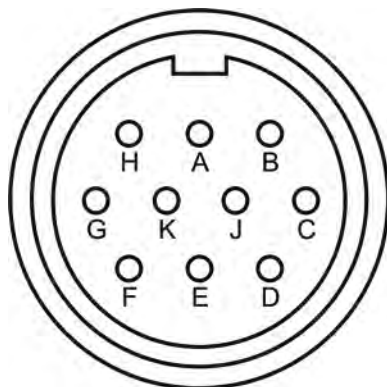

- A Piezo V1 +
- B Piezo V1 -
- C Piezo V2 +
- D Piezo V2 -
- E Pressure_Temp_GND
- F Temp.-Signal_WUS
- G Pressure_RxTx -
- H Pressure_RxTx +
- J Pressure_Temp._WUS_V +
- K Cable shield

Fig. 5-2 Plug wiring sensors CSM und CSP; connection to NFM 750

5.3.2 Sensor DSM

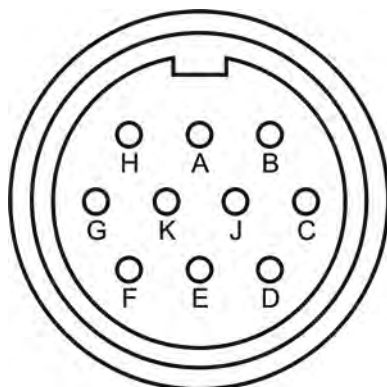

- A Piezo 125k +
- B Piezo 125k -
- C Piezo 200k +
- D Piezo 200k -
- E Pressure_Temp._GND
- F Temp.-Signal_LUS
- G Pressure_RxTx -
- H Pressure_RxTx +
- J Pressure_Temp._LUS_V +
- K Cable shield

Fig. 5-3 Plug wiring sensors DSM

5.3.3 Electronic Box EBM

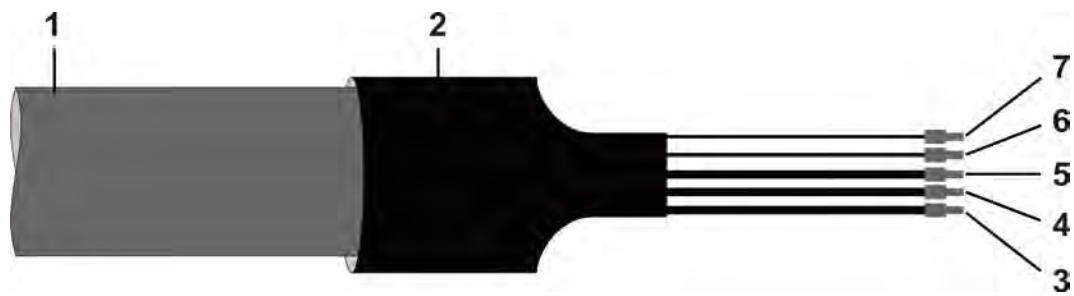

- 1 cable jacket
- 2 shrunk-on hose
- 3 black; cable shield (no ground)
- 4 red; power supply +; max. 9,9 V
- 5 blue; power supply -
- 6 white; RxTx +
- 7 green; RxTx -

Fig. 5-4 Cable end configuration; Electronic Box

5.3.4 Sensors POA and CS2

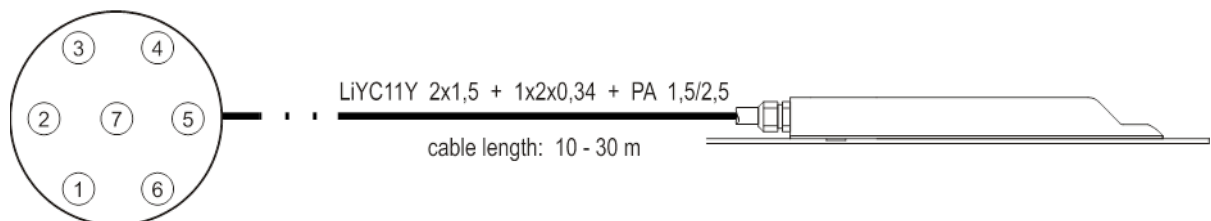

- 1 UE (voltage input, max. 9.9V)
- 2 RxTx + (RS485)
- 3 not connected
- 4 not connected
- 5 UE-GND (power supply ground)
- 6 shield (cable shield)

Fig. 5-5 Plug wiring sensors POA, CS2

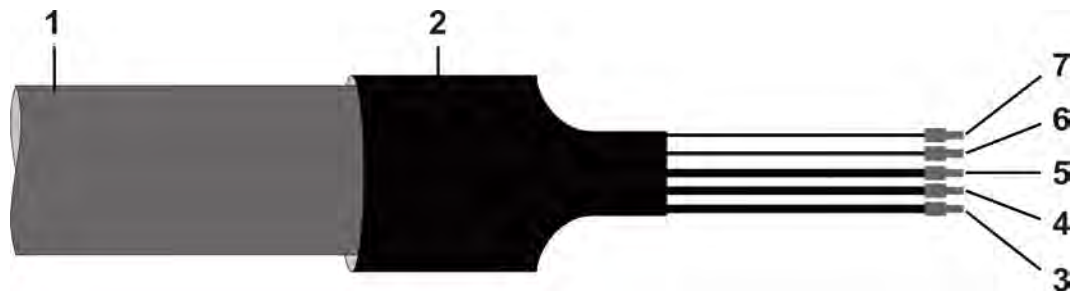

- 1 cable jacket
- 2 shrunk-on hose
- 3 black; cable shield (no ground)
- 4 red; power supply +; max. 9.9 V for Ex version; max. 24 V for non-Ex version
- 5 blue; power supply -
- 6 white; RxTx +
- 7 green; RxTx -

Fig. 5-6 Cable end configuration; sensors POA and CS2 without press. meas. cell

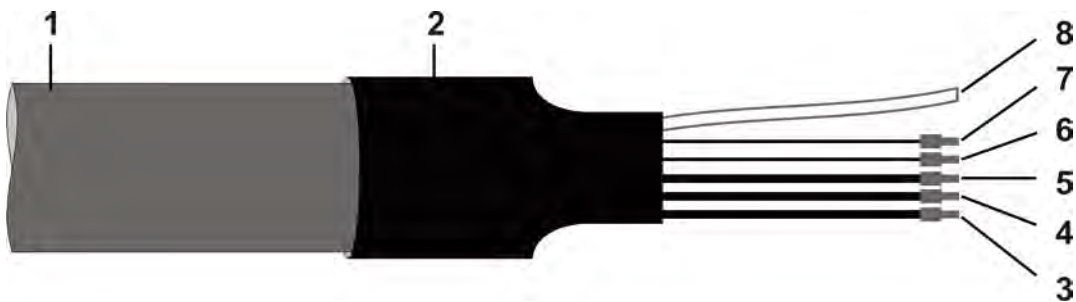

- 1 cable jacket
- 2 shrunk-on hose
- 3 black; cable shield (no ground)
- 4 red; power supply +; max. 9.9 V for Ex version; max. 24 V for non-Ex version
- 5 blue; power supply
- 6 white; RxTx +
- 7 green; RxTx -
- 8 air compensation hose

Fig. 5-7 Cable end configuration; sensors POA and CS2 with press. meas. cell

5.3.5 Sensor OCL

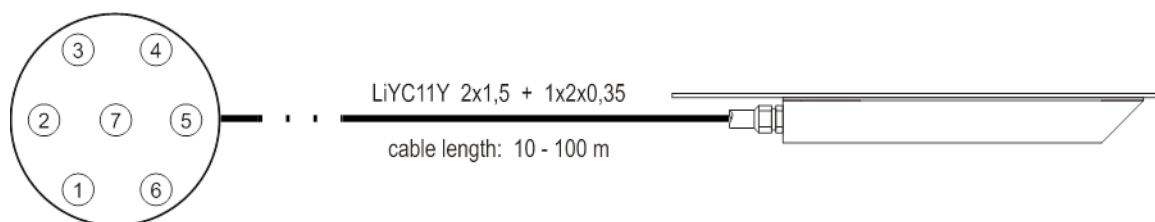

- 1 UE (voltage input, max. 9.9V)
- 2 RxTx + (RS485)
- 3 +mA (2-wire sensors)
- 4 -mA (2-wire sensors)
- 5 UE-GND (power supply ground)
- 6 shield (cable shield)

Fig. 5-8 Plug wiring sensor OCL

5.4 Cable extension

The cables of POA, CS2 and OCL sensors as well as the cable of the EBM Electronic Box EBM can be extended depending on the kind of sensor connection (for details see the table below).

DANGER



Danger of injury

Observe the maximum possible cable lengths in Ex areas! (see EU Type Examination Certificate at the end of this instruction manual)



Important Note

Cable extension and sensor connection should be accomplished by authorised expert staff only. This is to avoid sensor damage.



Important Note

Inappropriate connections leading to increased contact resistance or the use of unsuitable cables may result in interferences or even measurement failures.

If the sensor cable needs to be extended by using a junction box use a junction box made of metal. Connect the shields of incoming as well as outgoing cables necessarily to the ground connection of the junction box.

NIVUS cable specifications for POA-V2, CS2, OCL-L1 active sensors and EBM:

- Cable capacity (blue/red): 100 pF/m
- Cable inductance (blue/red): 0.76 μ H/m

These values are of significant importance to an Ex application as soon as operators need to create a certification of intrinsic safety for their facility which requires to consider the connectable external capacity C_o or the inductance L_o .

Laying of cables in the ground:

The sensor cable fixed on the sensor is not designed to be laid in the ground permanently. If you wish to lay signal cables into the ground, concrete or similar please use additional protective pipes or hoses with sufficient inner diameters. Select inner diameter, bending radius and layout of protective pipes and hoses in a way which enables to remove old sensor cables and to draw in new ones without any problems.

Possible cable extensions:

Sensor connection	Sensor or EBM	Cable extension
K Preconfigured for EBM and for sensors without pressure measurement cell, cable end preconfigured for connection to NF7, NFP, OCM Pro CF	EBM POA-V200 POA-V2H1 CS2-V200 CS2-V2H1 OCL	Extension with single-shielded signal cable.
L For sensors with pressure measurement cell, cable end preconfigured for connection to NF7, NFP, OCM Pro CF	POA-V2D0 POA-V2U1 CS2-V2D0 CS2-V2U1	Extension possible only when the Type ZUB0 DAE pressure compensation element by NIVUS is used: connect the sensor cable ends to the terminal clamps of the junction box of the pressure compensation element and extend from there by using a single-shielded signal cable (see Fig. 5-12).
F For sensors with pressure measurement cell, incl. plug and filter element	POA-V2D0 POA-V2U1 CS2-V2D0 CS2-V2U1 CSP-V2D0 CSP-V2U1	No extension possible.
S For EBM and for sensors without pressure measurement cell, incl. plug	EBM POA-V200 POA-V2H1 CS2-V200 CS2-V2H1 CSP-V200 CSP-V2H1 OCL-L1	No extension possible.

NIVUS recommend cable type A2Y(L) 2Y 6x2x0.8 (or more wires) for extension purposes

Cable extension using Type A2Y(L) 2Y cable:

- Extend each of the twisted signal conductors (RxTx) for bus communication with one wire.
- Combine the same number of remaining wires in two strands for UE + and for GND and extend these strands depending on the distance between sensor and transmitter using one or more wire(s) connected in parallel per connecting cable.
Solder or press parallel wires for UE + and GND per connecting cable together.

The table below provides an overview on the **minimum number of wires per connection** for the extension cable Type A2Y(L) 2Y.

The **minimum number of wires per connection** is specified as follows: x (y)

- x = minimum total number of wires incl. data lines
- y = wires for power supply + and -

The specified cable lengths relate to non-Ex sensors.

Extension to	Minimum number of wires per connection				Remarks
	Sensor ¹ - NF7x		Sensor ² - NFP 2 ³		
	10 m cable on sensor	30 m cable on sensor	10 m cable on sensor	30 m cable on sensor	
30 m	4 (2)	none	4 (2)	none	
50 m	4 (2)	4 (2)	4 (2)	4 (2)	
70 m	4 (2)	4 (2)	4 (2)	4 (2)	
100 m	4 (2)	4 (2)	4 (2)	4 (2)	
150 m	6 (4)	6 (4)	4 (2)	4 (2)	
200 m	6 (4)	6 (4)	4 (2)	4 (2)	
250 m	8 (6)	8 (6)	4 (2)	4 (2)	Commissioning through NIVUS service required.
300 m	8 (6)	8 (6)	4 (2)	4 (2)	
400 m	10 (8)	10 (8)	4 (2)	4 (2)	
500 m	12 (10)	12 (10)	6 (4)	4 (2)	
700 m	14 (12)	16 (14)	6 (4)	6 (4)	
1000 m	20 (18)	20 (18)	8 (6)	8 (6)	

Cable extension using other cable types:

- For international use it is possible to use signal cables of other types with a minimum diameter of 0.8 mm² and a common cable shield. Bei Unsicherheiten zur Eignung des Signalkabels wenden Sie sich an NIVUS und fügen Sie ein aussagekräftiges Kabeltypdatenblatt bei.
- Extension using equivalent cables using other cross-sections on request.

¹ POA-V2, CS2, OCL sensors and EBM Electronic Box

² POA-V2, CS2, OCL sensors and EBM Electronic Box

³ Not applicable for NFP

More than one sensor cable sharing one extension:

In applications featuring more than one flow velocity sensor it is possible to extend the sensor cables using one shared signal cable.



Important Note

It is not allowed to use common extensions in case of different applications or to use a common signal cable to extend separate level and flow velocity measurements.

5.5 Pressure compensation elements

5.5.1 General

Use NIVUS pressure compensation elements exclusively to operate sensors with integrated pressure cell.

The pressure compensation element is equipped with 2 drying capsules or dry granulate. These capsules / dry granulate prevent(s) moisture from leaking in and preserve electronic components.

- The drying capsules / dry granulate shall be checked and replaced if required regularly (depending on the ambient conditions).
- Replace the drying capsules / dry granulate if required.
- Please observe the maintenance hints in chapter 6.3.2 und 6.3.3.

CAUTION



Sensor damage through ingress of moisture

Moisture leaking into the cell will irreversibly damage the built-in electronic components of the sensor!

- *Always operate sensors featuring a built-in pressure measurement cell with pressure compensation element. The drying capsules / dry granulate avoid(s) ingress of moisture!*
- *Never operate sensors with integrated pressure cell without or with used drying capsules / dry granulate.*
- *Please regularly check and replace the drying capsules/ dry granulate if required.*

⇒ Pressure compensation elements, replacement filters, dry capsules and dry granulate see chapter 8.

5.5.2 Pressure compensation element for CSM and CSP Sensors

The pressure compensation element for CSM and CSP sensors is equipped with 2 drying capsules bzw

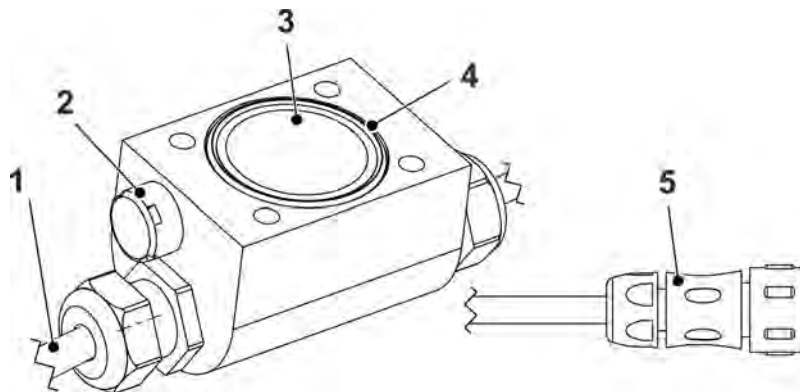

- 1 Cable to sensor
- 2 Pressure compensation diaphragm
- 3 2 drying capsules with acrylic glass cover
- 4 O-ring – please observe the ring is placed correctly! (See 6.3.2)
- 5 Plug for connection to Electronic Box / NFM 750

Fig. 5-9 Pressure compensation element for connecting to EBM

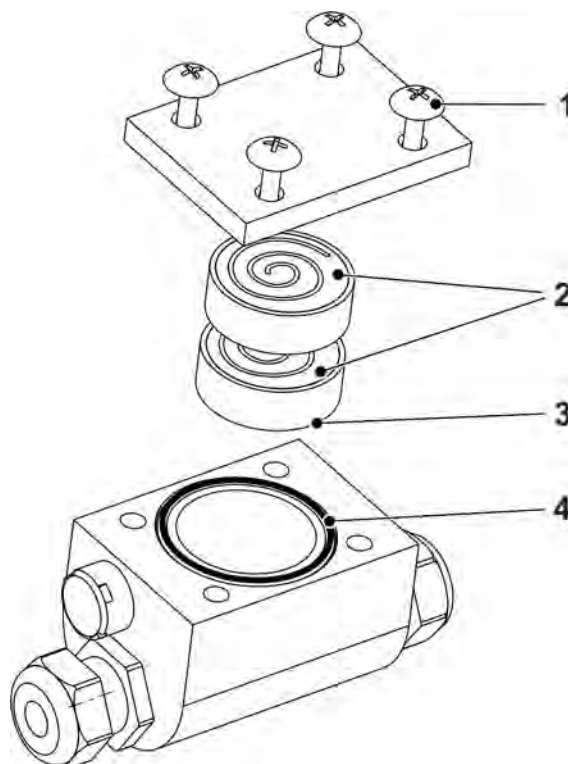

- 1 Crosshead screws to open the cover (acrylic glass)
- 2 2 replaceable drying capsules
- 3 Insert with board surface down (see 6.3.2)
- 4 O-ring – observe correct placement – keep free of dirt (see 6.3.2)

Fig. 5-10 Exploded view drawing of pressure compensation element

5.5.3 Pressure compensation element for POA- and CS2- sensors

Sensors with sensor connection types „F“ or „S“ have a configured plug, type „F“ additionally have a preconfigured filter element, which works as a pressure compensation element (see figure below.)

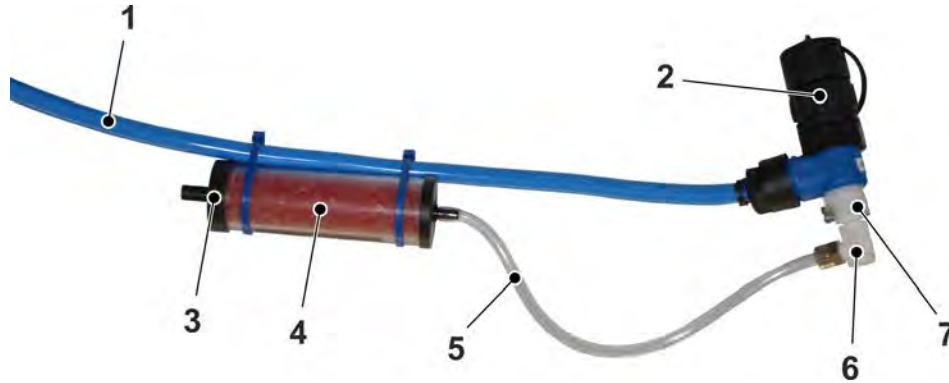

- 1 Sensor cable
- 2 Sensor plug
- 3 Filter cover (screwed)
- 4 Air filter (filled with dry granulate and fastened to sensor cable with cable clip)
- 5 Air hose
- 6 Air hose plug
- 7 Socket for air hose plug

Fig. 5-11 Filter element for connection to PCM

Cables on sensors with pressure measurement cell (Types V1D, V2D, V2U) must not be extended. The maximum uninterrupted cable length is 30 m. Longer cables require the installation of a junction box with pressure compensation (pressure compensation element) (see Fig. 5-12, Pos. 4 and 5).

This pressure compensation element has to be installed even if the cable of a sensor with integrated pressure measurement cell is connected directly an einen Messumformer der Typen NivuFlow 750, NivuFlow 7550 or to the OCM Pro transmitter.

It is available directly from NIVUS under order article no. >ZUB0 ZDAE<.

The pressure compensation element supplied by NIVUS for POA and CS2 sensors consists of several components:

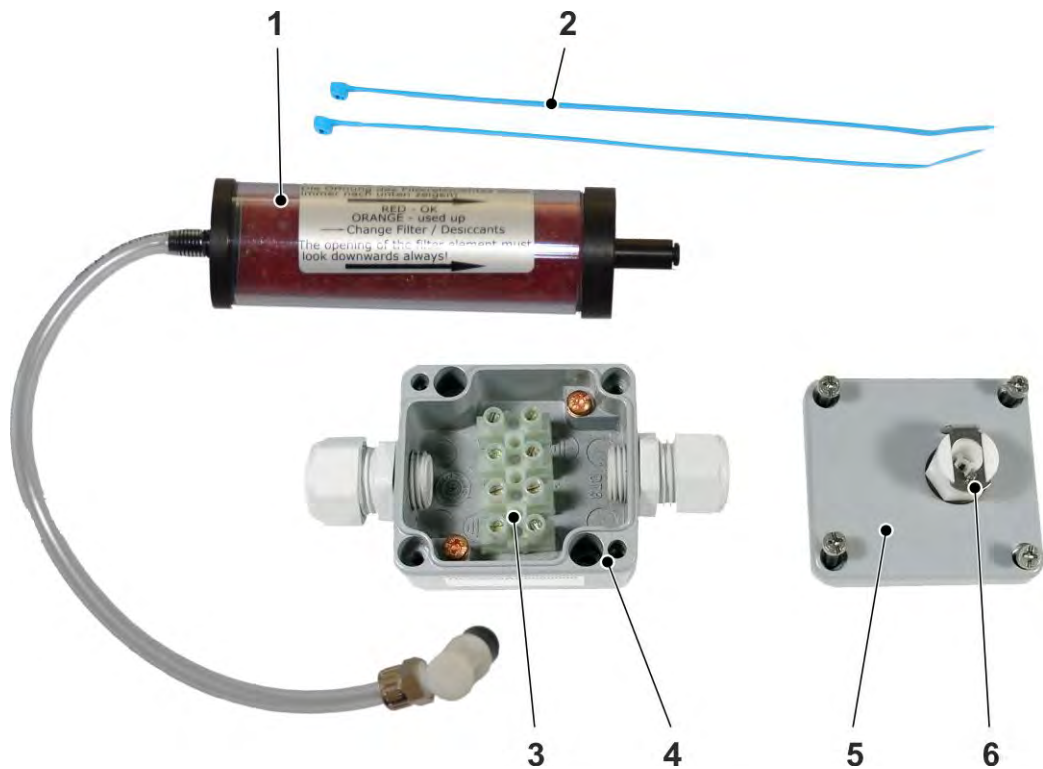

- 1 Filter element consisting of air filter, air hose and air hose plug
- 2 Cable clips
- 3 Terminal clamps
- 4 Connection box
- 5 Box cover
- 6 Self-locking socket for air hose plug

Fig. 5-12 Components of air compensation element

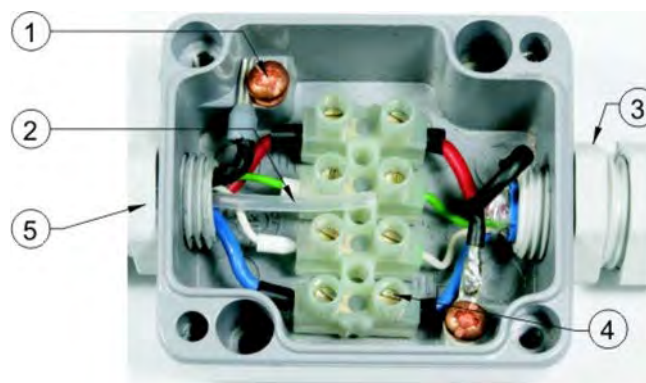

- 1 Shield
- 2 Air hose
- 3 Transmitter side
- 4 Terminal clamps
- 5 Flow velocity sensor side

Fig. 5-13 Open connection box

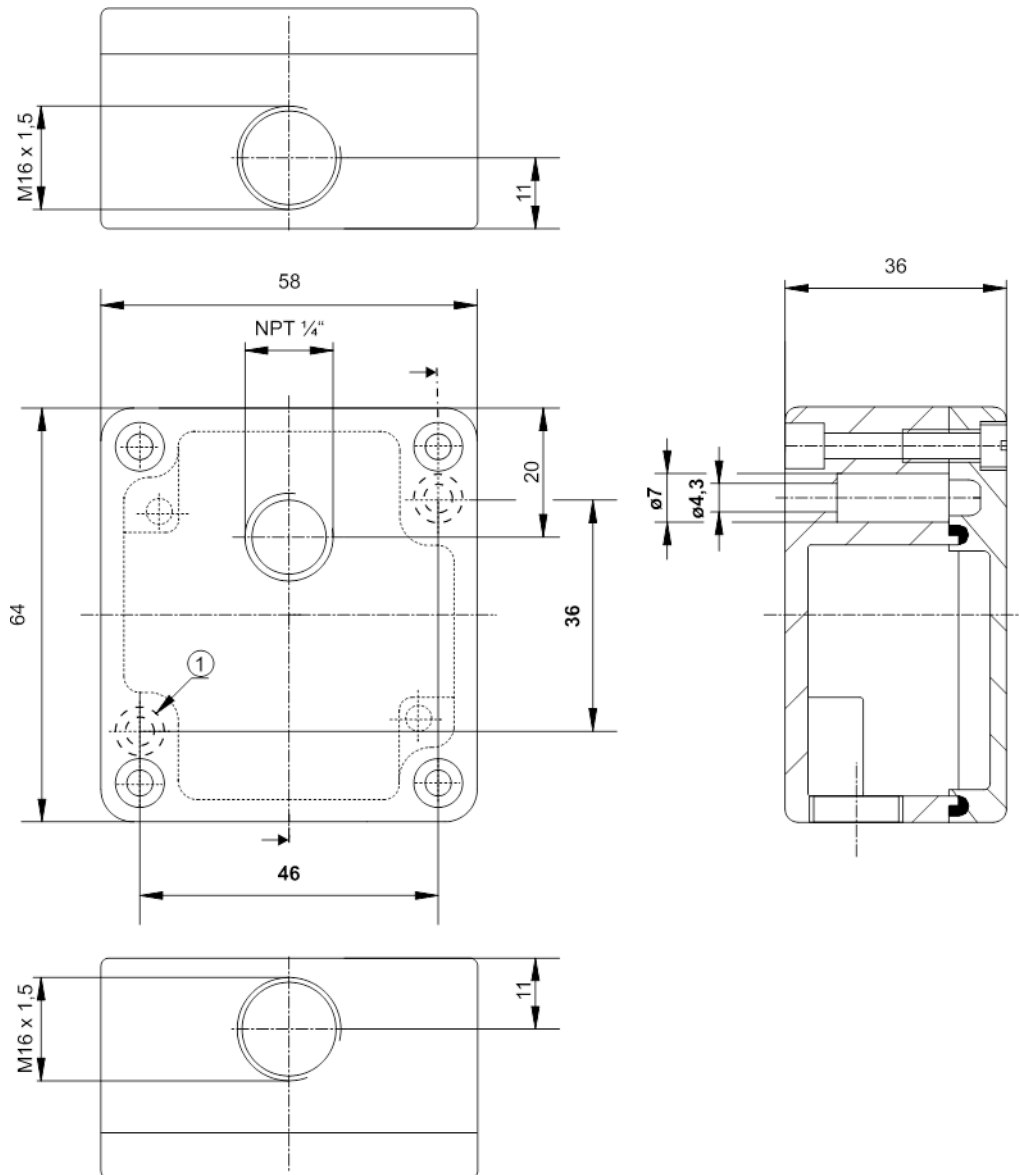

1 Fastening holes

Fig. 5-14 Connection box dimensions

Connect pressure compensation element and air filter



Important Note

The connection box with air compensation has to be installed in an area without corrosive gases and which is durably protected from being flooded.

Please necessarily connect the shields of feed and return cable to the shield connections of the metal connection box. Otherwise faulty results or even measurement failures may occur.

*To protect from water drops the cover of the air filter must **always face downwards**.*

Between junction box and transmitter use a signal cable Type A2Y or a similar appropriate signal cable with integrated common shield.

Procedure:

1. Connect the 5-wire cable from the sensor to the terminal clamp rail inside the junction box. Make sure to connect only the power supply (red + blue) and the signal bus lines (white + green, *Fig. 5-13*).
2. Connect the cable shield (black) to one of both shield clamps within the junction box (*Fig. 5-13*, Pos. 1).
3. Use both accompanying cable clips to fasten the air filter to the cable so that the filter cover is facing downwards (*Fig. 5-15*).
4. Snap the air hose plug into the socket in the cover (*Fig. 5-12*, Pos. 6).
5. Put on the junction box cover and tighten the screws.



Fig. 5-15 Assembled pressure compensation element



Important Note

Never operate the measurement incl. pressure compensation element with unplugged air hose plug automatic self-locking mechanism of the integrated socket (→ will shift the zero point of the level measurement).

5.6 Table of Resistiveness

CAUTION



Damage due to aggressive media

As a basic principle, damage might occur in case of using chloride media (pitting corrosion in stainless steel ground plate or sensor jacket), hydrogen sulphide (H₂S – risk of diffusion through cable sheath or sensor body resulting in destruction of copper wires and conductor paths) as well as various organic solvents (may dissolve cable sheath or sensor body)!

Sensors and cables shall be installed exclusively in media according to the table of resistiveness below.

Sensor installation and cable layout shall be executed exclusively in media according to the table of resistiveness below! Otherwise the measurement system may be damaged irreversibly.

The medium contacting parts of the sensors consist of:

- V4A (ground plate or pipe sensor jacket)
- PPO GF30 (sensor body)
- PEEK (sensor crystal cover)
- Polyurethane (cable sheath and glands)
- PTFE (gasket of sensor screw joint)
- PVDF (sensor body CSM-V100K)

The following materials are used additionally for sensors with pressure measurement cell:

- Hastelloy® C-276
- Viton® (PA/PR)

The sensor technology is resistant to normal domestic sewages, dirt and rain water as well as mixed water from municipalities and communities. Also in many industrial plants (e.g. Huels, BASF etc.) the resistance does not present any problems. The sensor technology nevertheless is not resistant to all substances and substance mixtures.

Please observe that substance mixtures (several substances being present simultaneously) under certain circumstances may cause catalytic effects which might not occur if the individual substances are in use. Due to infinitely possible combinations these catalytic effects cannot be verified entirely.

If in doubt please contact your NIVUS representative and request a free material sample for long time testing purposes.

For use in special applications with high aggressive or solvent-containing media there are sensors made of full PEEK available with ground plates made of Hastelloy or Titanium as well as pipe sensors made of high resistant special steel. Sensor cables which have to be immersed into the medium are available with a special FEP coating (resistant to organic solvents or hydrogen sulphide).

MEDIUM	FORMULA	CONCENTRATION	HDPE	PPO GF30	PUR	PEEK	FEP	V4A	Hastelloy C 276	Viton (PA/PR)	PA	PVDF
Acetaldehyde	C ₂ H ₄ O	40%	3/3	4	4	1	(1)	(1)	0	4/4	2/4	4/4
Acetic acid	C ₂ H ₄ O ₂	10%	1/1	2	3	1	1/1	1/1	1	(3)	4/4	1/1
Acetone	C ₃ H ₆ O	40%	1/1	4	4	1	(1)	1/1	1	4/4	1/0	3/4
Allyl alcohol	C ₃ H ₆ O	96%	1/3	2	0	1	1/1	1/1	0	4/4	3/0	(2)
Aluminium chloride	AlCl ₃	10%	1/1	2	0	1	1/1	3/4	1	1/0	1/0	1/1
Ammonium chloride	(NH ₄)Cl	watery	1/1	1	0	1	1/1	1/2L	1	1/1	3/4	1/1
Ammonium hydroxide	NH ₃ + H ₂ O	5%	1/1	2	4	1	1/1	1/1	1	(2)	(2)	(2)
Aniline	C ₆ H ₇ N	100%	1/2	3	4	1	1/1	1/0	1	2/4	3/4	1/4
Benzene	C ₆ H ₆	100%	3/4	3/4	2	1	1/1	1/1	1	3/3	2/0	1/3
Benzyl alcohol	C ₇ H ₈ O	100%	3/4	3	2	1	1/1	1/1	1	1/0	4/4	1/1
Boric acid	H ₃ BO ₃	10%	1/1	1	1	1	1/1	1/1	1	1/1	1/0	1/1
Bromic acid	HBrO ₃	cocontr.	0/0	0	3	1	0/0	(4)	0	(2)	(4)	(1)
Butanol	C ₄ H ₁₀ O	techn.pure	1/1	2	3	1	1/1	(1)	1	3/4	1/0	(2)
Calcium chloride	CaCl ₂	spirituous	1/0	1	1	1	1/1	1/2L	1	1/1	4/4	1/1
Carbon disulphide	CS ₂	100%	4/4	2	0	1	1/1	1/1	1	1/0	3/0	1/0
Carbon tetrachloride	CCl ₄	100%	4/4	3	4	1	1/1	1/1L	1	1/1	4/4	1/1
Caustic soda	NaHO	50%	1/1	1	3	1	1/1	1/3	1	3/3	1/0	1/1
Chlorine	Cl ₂		4/4	3	3	1	1/1	1/0	0	1/1	4/4	1/0
Chlorine water	Cl ₂ x H ₂ O		3/0	2	0	1	(1)	2/0L	1	1/0	4/4	1/1
Chlorobenzene	C ₆ H ₅ Cl	100%	3/4	3	4	1	1/1	1/1	1	3/4	4/4	1/1
Chloroform	CHCl ₃	100%	3/4	4	4	1	1/1	1/1	1	4/4	¾	1/1
Chloromethane	CH ₃ Cl	techn.pure	3/0	4	4	1	1/0	1/1L	0	4/4	(3)	1/0
Chromic acid	CrO ₃	10%	1/1	1	0	1	1/1	1/2	1	1/1	4/4	1/1
Citric acid	C ₆ H ₈ O ₇	10%	1/1	1	1	1	1/1	1/1	1	1/1	1/1	1/1
Diesel	—	100%	1/3	2	0	1	(1)	(1)	0	1/1	1/1	1/1
Ethanedioic acid	C ₂ H ₂ O ₄ x	watery	1/1	2	0	1	1/1	1/3	2	1/1	4/4	1/1
Ethanol	C ₂ H ₆ O	96%	1/0	1	1	1	1/1	1/1	1	3/0	1/0	1/1
Ethyl acetate	C ₄ H ₈ O ₂	100%	1/3	3	3	1	1/1	(1)	0	4/4	1/0	1/1
Ethyl alcohol	C ₂ H ₆ O	100%	1/0	1	1	1	1/1	1/1	0	3/0	1/0	1/1
Ethylen chloride	C ₂ H ₄ Cl ₂		3/3	4	3	1	1/1	1/1L	1	3/0	3/0	1/1
Ferric chloride	FeCl ₃	saturated	1/1	2	3	2	1/1	4/4	0	1/1	3/0	1/1
Formaldehyd dilution	CH ₂ O	10%	1/1	1	2	1	1/1	1/1	1	3/0	3/3	1/1
Glycerin	C ₃ H ₈ O ₃	90%	1/1	1	2	1	1/1	1/1	1	1/1	1/0	1/1
Heptane	C ₇ H ₁₆	90%	2/3	1	1	1	1/1	1/1	1	1/1	1/0	1/1
Hexane	C ₆ H ₁₄	100%	2/3	1	2	1	1/1	1/1	1	1/1	4/4	1/1
Hydrochloric acid	HCl	1-5%	1/1	1	3	1	1/1	4/4	1	1/1	4/4	1/1
Hydrofluoric acid	HF	50%	1/1	2	3	1	1/1	4/4	2	1/3	4/4	1/1
Hydroxypropionic	C ₃ H ₆ O ₃	3%	1/1	1	0	1	1/1	1/1	1	1/1	(3)	1/1
Isopropanol	C ₃ H ₈ O	techn.pure	1/1	1	2	1	1/1	(1)	1	1/1	1/0	1/1
Magnesium chloride	MgCl ₂	watery	1/1	1	2	1	1/1	1/0L	1	1/1	1/0	1/1
Mercuric chloride	HgCl ₂	watery	1/1	1	0	1	1/1	(4)	1	1/1	4/4	1/1
Methanol	CH ₄ O		1/1	1	2	1	1/1	1/1	1	3/4	2/0	1/1
Methyl acetate	C ₃ H ₆ O ₂	techn.pure	1/0	3	0	1	1/0	1/1	1	4/4	1/0	1/1
Nitric acid	HNO ₃	1-10%	1/1	1	3	1	1/1	1/1	1	1/1	4/4	1/1
Nitrobenzene	C ₆ H ₅ NO ₂		3/4	3	4	1	1/1	1/1	0	4/4	4/4	1/1
Oleic acid	C ₁₈ H ₃₄ O ₂	techn.pure	1/3	1	1	1	(1)	1/1	0	2/2	1/0	1/1
Ozone	O ₃		3/4	2	2	1	1/1	0/0	0	1/0	4/4	(1)
Petrol, unleaded	C ₅ H ₁₂ - C ₁₂ H ₂₆		2/3	3	2	1	1/1	1/1	1	(1-	1/0	1/1
Petroleum	—		1/1	1	1	1	1/1	1/1	1	1/1	(1)	1/1
Petroleum	—	techn.pure	1/3	3	1	1	(1)	1/1	0	1/0	1/0	0/0
Phenol	C ₆ H ₆ O	100%	2/3	3	2	1	1/1	1/1	1	2/3	4/4	1/1
Phenylmethane	C ₇ H ₈	100%	3/4	3	3	1	1/1	1/1	0	3/3	1/0	1/0
Phosphoric acid	H ₃ PO ₄	85%	1/1	1	0	1	1/1	1/3	1	1/1	4/4	1/1
Potassium hydroxide	KHO	10%	1/1	1	3	1	1/1	1/1	1	4/4	1/0	1/1
Potassium nitrate	KNO ₃	watery	1/1	1	0	1	1/1	1/1	1	1/1	1/0	1/1
Sodium bisulphite	NaHSO ₃	watery	1/1	1	0	1	(1)	1/1	1	1/0	1/0	1/1
Sodium carbonate	Na ₂ CO ₃	watery	1/1	1	3	1	1/1	1/1	1	1/1	1/0	1/1
Sodium chloride	NaCl	watery	1/1	1	2	1	1/1	1/2	1	1/1	1/1	1/1
Sodium sulphate	Na ₂ SO ₄	watery	1/1	1	0	1	1/1	1/1	1	1/1	1/0	1/1
Sulphuric acid	H ₂ SO ₄	40%	1/1	1	3	1	1/1	2/3	1	1/1	4/4	1/1
Trichloroethylene	C ₂ HCl ₃	100%	3/4	4	4	1	1/1	1/1L	1	1/3	3/0	1/0
Vegetable oils	—		0/0	1	1	1	(1)	1/1	0	1/0	0/0	1/1

5.6.1 Resistiveness Legend

Resistiveness

There are two values per medium:

left number = value at +20 °C /

right number = value at +50 °C.

- 0 no specifications available
- 1 very good resistance/suitable
- 2 good resistance/suitable
- 3 limited resistance
- 4 not resistant
- K no general specifications possible
- L risk of pitting corrosion or stress corrosion cracking
- () estimated value

Material Names

HDPE	Polyethylene, high density
FEP	Tetrafluorethylene-Perfluorpropylene
V4A	Stainless steel 1.4401 (AISI 316)
PPO GF30	Polyphenyloxylene with 30% glass fibres
PU	Polyurethane
PEEK	Polyetheretherketone
PA	Polyamide
PVDF	Polyvinylidenfluoride

6 Cleaning and Maintenance

6.1 Basics of Cleaning

WARNING**Germ contamination**

Due to using the sensors mostly in the waste water field which may be contaminated with hazardous germs.

In case of contact with sensors and cables:

- *Observe the regulations on safety at work Arbeitsschutzbestimmungen*
- *Always wear protective clothing.*

In heavily polluted media tending to sedimentation it may be necessary to clean the flow velocity sensor regularly. To do this use a brush with plastic bristles, a broom or similar.

Clean and dry dirty plug contacts (sensor connection F or S) before you reconnect the sensors. Remove dried dirt carefully by using compressed air or a brush with plastic bristles (no metal). If required use contact spray to maintain contacts.

CAUTION**Damage through hard objects**

- *Never use hard objects such as wire brushes, rods, scrapers or similar to clean the sensor.*
- *Cleaning by using a water jet is allowed up to a max. pressure of 4 bar (see 4.5 Specification) (e.g. by using a water hose).*
- *Never clean flow velocity sensors with pressure measurement cell (types V1D, V2D and V2U) by **using a water jet!***
- *Do not clean sensor with a high pressure cleaner. The use of such equipment may damage the sensor resulting in measurement failure.*

6.2 Cleaning wedge sensors

CAUTION**Material damage and measurement errors due to loose parts**

Removing or loosening of ground plate or cable gland result in leakage and therefore will cause measurement and sensor failure.

- *Do not remove parts.*

**Important Note**

If sedimentation which cannot be removed prevents correct measurement the sensor must be maintained by NIVUS. For this purpose return the sensor padded and packed as good as possible to NIVUS.

CAUTION



Damage of pressure measurement cell during cleaning

Never clean the pressure cell using a water jet. Just dip the sensor into a bucket filled with water and clean by slightly moving it.

The cover of the pressure measurement cell is sealed with a label on the ground plate. This warning label shall never be damaged or removed. Do not loosen the screws underneath the label.

Disregarding invalidates the manufacturer warranty. If in doubt please let NIVUS do the cleaning.

Flush the duct milled into the ground plate with water **immediately every time after dismantling** in order to avoid accumulation of deposits. For this purpose dip the sensor into water several times.

6.3 Maintenance wedge sensors

6.3.1 Wedge Sensors with Pressure Measurement Cell

Due to physical reasons, level measurements performed by sensors with pressure measurement cell are subject to long-term drift (see *5.5.3 Pressure compensation element for POA- and CS2- sensors*).

NIVUS therefore recommend calibration of sensors with integrated pressure measurement cell twice a year regarding the respective zero point. The best results are going to be achieved if the water level is as low as possible or if the sensor has been removed from the measurement medium.



The calibration procedure is described in according Instruction Manuals of OCM Pro, NivuFlow or PCM transmitters.

Wedge sensors with pressure measurement cell on the connection plug or the compensation element are additionally equipped with a filter element containing dry granulate or drying capsules. Dry granulate and drying capsules are subject to natural wear and tear which depends on:

- measurement duration
- measurement interval
- air pressure fluctuation
- environmental conditions

Check the air filter or the drying capsules periodically or prior to every use. Wear is indicated by a colour change of the dry granulate or the drying capsules (see label on the air filter or the pressure compensation element). Once the colour of the dry granulate begins to change either replace the granulate or replace the filter element by another one of the same specification. Replace the drying capsules as soon as the colour begins to change.

⇒ Spare filters, dry granulate and drying capsules see *8 Accessories and Spare Parts*.

6.3.2 Pressure Compensation Element for CSM and CSP Sensors

When using CSM and CSP sensors with pressure measurement cell and pressure compensation element the built-in drying capsules (see *Fig. 5-10*) need to be regularly checked and replaced if required. Inspection intervals depend on the prevailing air humidity and may vary between 2 and 12 weeks depending on application.

As soon as the drying capsules are used up their colour will change from orange to white. The capsules then need to be replaced.

- ORANGE = new capsule / not yet used up
- WHITE = capsule used up – please replace both capsules

⇒ Spare capsules are available from NIVUS (see *8 Accessories and Spare Parts*).



Note

When replacing the drying capsules please observe the glued O-ring to remain in the groove. Necessarily keep the ring free of dirt since otherwise the pressure compensation element may leak.

Replace drying capsules:

1. Unscrew the four crosshead screws of the acrylic glass cover and remove the cover (see *Fig. 5-10*, Pos.1)
2. Remove used drying capsules (can be disposed with household waste)
3. Peel off the aluminium foil from the new drying capsules
4. Insert the new drying capsules with the cardboard side down
5. Check the position of the o-ring and put it into the groove again if necessary (see *Fig. 5-9 / Fig. 5-10*, Pos. 4)
6. Put on the cover and fasten using the 4 crosshead screws.
Make sure to avoid dirt, sand or similar between pressure compensation element and cover.

6.3.3 Pressure Compensation Element for POA and CS2 Sensor

Inspect the filter element regularly when mounting POA or CS2 sensors with pressure measurement cell and pressure compensation element (see *Fig. 5-11*).

Inspection intervals depend on the prevailing air humidity and may vary between 2 and 12 weeks depending on application.

Wear of the air filter is indicated by a colour change of the dry granulate (see label on the air filter). If the colour of the dry granulate should change by more than 50% replace dry granulate or filter element.

⇒ Spare filter elements and dry granulate can be purchased from NIVUS (see *8 Accessories and Spare Parts*).



- 1 Dry granulate
- 2 Filter plate
- 3 Filter cover

Fig. 6-1 Air filter, open

Replace dry granulate:

1. Cut the cable clips fastening the filter on the cable
2. Press the release key on the socket of the sensor cable



- The air hose plug is released from the socket
3. Unscrew filter cover (*Fig. 6-1, Pos.3*)
4. Remove filter plate (*Fig. 6-1, Pos. 2*)
5. Dispose use dry granulate (can be disposed with household waste)
6. Refill air filter with new dry granulate
7. Use the filter plate with the fine side facing the thread to cover the dry granulate
8. Put on the filter cover again and tighten
9. Replug the air hose plug into the socket of the sensor cable
→ The air hose plug snaps into place.
10. Fasten the air filter on the sensor cable using new cable clips

6.4 Cleaning and maintenance sensors OCL and DSM

These sensors are normally non-contacting. Hence, it is necessary to check if the transmitting pad is not covered and the sound beam is free to reach the water surface after immersion (flooding) into the measurement medium only.

In case of pollution clean the sensor with water and a cloth or a soft brush.

CAUTION



Material damage and measurement errors through loose or dismantled parts

Removing or loosening mounting plate or cable gland results in leakage and therefore will cause measurement and sensor failure.

In principle do not remove sensor parts (exceptions see Fig. 6-2 and Fig. 6-3).

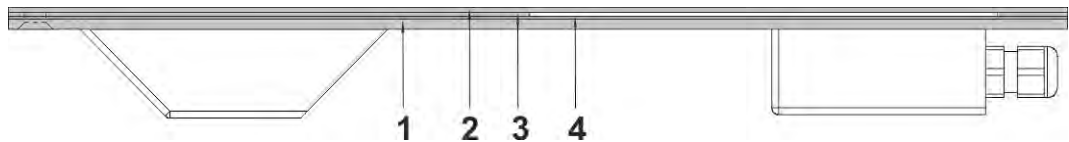

- 1 **Never dismantle** the ground plate!
- 2 Cover sheet, can be removed
- 3 Spacer sheet short and long, can be removed
- 4 Intermediate sheet, can be removed

Fig. 6-2 DSM Sensor: overview on parts which can be / can be not dismantled

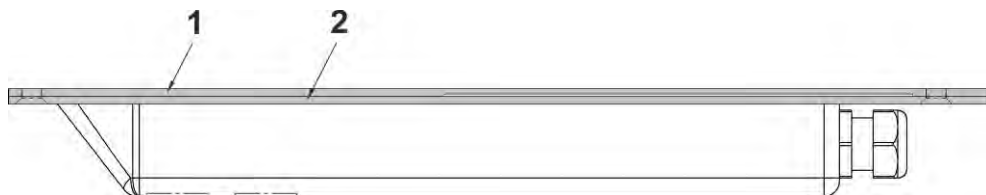

- 1 Cover sheet, can be removed
- 2 **Never dismantle** the ground plate!

Fig. 6-3 OCL Sensor: overview on parts which can be / can be not dismantled

6.5 Cleaning and maintenance pipe sensors POA and CS2

The pipe sensor can be removed from the pipeline for maintenance or control purposes without any problems. The sensor position is fixed due to the retaining element.



Description of retaining element and sensor screw connection see Installation Instruction Correlation and Doppler Sensors.

Dismantle pipe sensor POA or CS2:

1. Unscrew the union nut of the sensor screw connection.



2. Loosen both hexagon socket screws on the top clamp element on the reverse side of the retaining element.
3. Remove pipe sensor.
Both screwed clamp elements on the reverse side remain to be unchanged on the pipe sensor body. During reinstallation both elements serve as stop and positioning aid.



Clean pipe sensor:

⇒ See chapter 6.1

Reinstall pipe sensor POA or CS2:

1. Replace o-ring (Art.-No. ZUB0 SCHNEID 15PT) and white sealing ring (PDFE; Art.-No. E-PMA-ORING 35) in the sensor screw connection and slightly grease.
2. Insert sensor into sensor screw connection. The clamp elements must be connected again.
3. Tighten union nut on the sensor.
4. Screw the retaining element together again using both M5 hexagon socket screws.

6.6 Cleaning and maintenance pipe sensor CSM

The pipe sensor can be removed from the pipeline for maintenance or control purposes.



Description of pipe sensor CSM see Installation Instruction Correlation and Doppler Sensors

Dismantle pipe sensor CSM:

1. Read and note insertion depth at pipe sensor scale

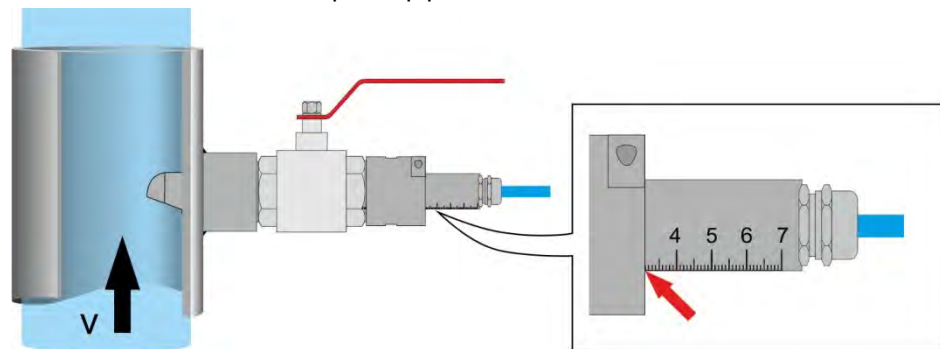

2. Mark the sensor position (scale on pipe sensor) on sensor clamping. The marking helps adjusting the sensor while reinstalling.

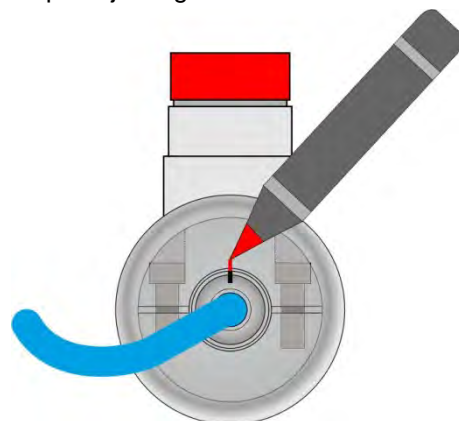

3. Release the two cylinder bolts M5 on the sensor clamping with a 4 mm hex key

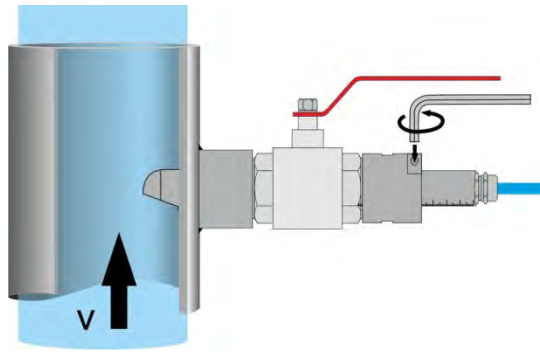

4. Withdraw the pipe sensor up to the stop collar

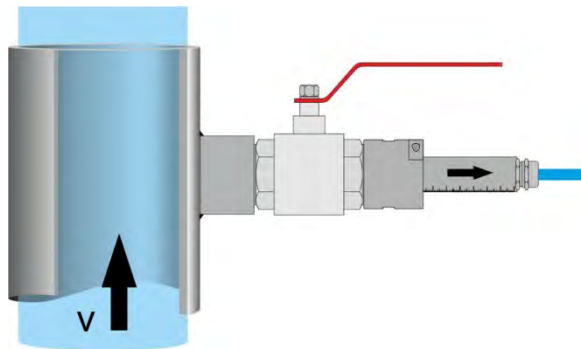

5. Close stop ball valve immediately.

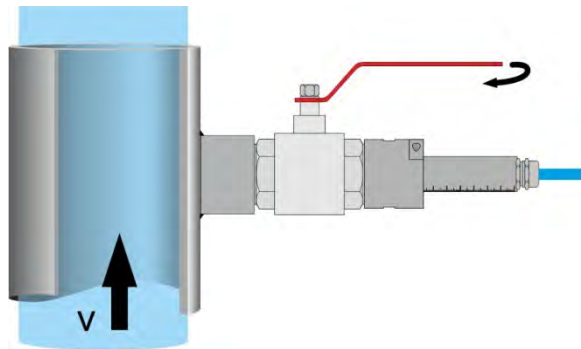

→ No liquid can pour out from the pipe

6. Use 2 spanners (size 36 and 39) to unscrew sensor clamping from stop ball valve, make sure to turn the cable too.

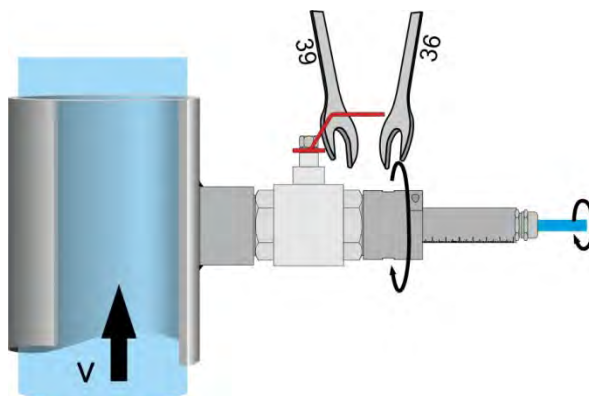

→ The pipe sensor is connected with the clamping only.

7. Remove pipe sensor, the sensor clamping remains loosely connected with the pipe sensor. Take care not to lose the flat gasket.

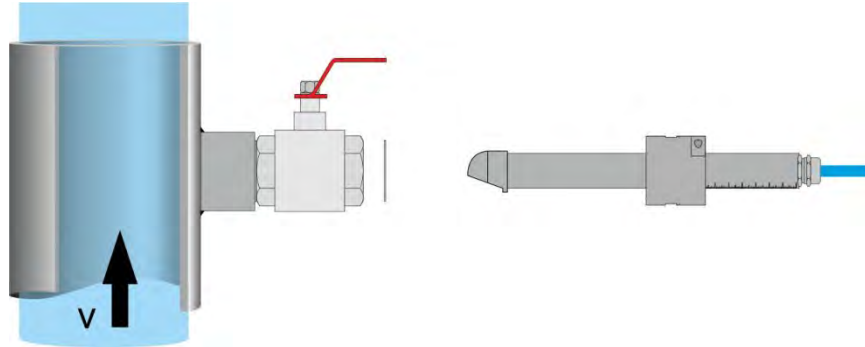

Clean pipe sensor:

⇒ See chapter 6.1

Reinstall pipe sensor in reversed order:

1. Insert pipe sensor into stop ball valve.
 2. Fasten sensor clamping:
 - a) Insert flat gasket between stopball valve and sensor clamping correctly.
 - b) Use 2 spanners (size 36 and 39) to tighten the sensor clamping on the stop ball valve by a minimum of 10 Nm, make sure to turn the cable too.
 3. Open stop ball valve and insert pipe sensor into pipe, Insertion depth as noted while disassembling.
 4. Adjust pipe sensor according the marking from the disassembling.
 5. Align centre line to look upstream.
 6. Use a 4 mm Allen® key to tighten both screws on the sensor clamping by approx. 3.4 Nm.
- The pipe sensor is installed firmly.

6.7 Installation of Spare Parts and Parts subject to wear and tear

We herewith particularly emphasise that replacement parts or accessories not supplied by NIVUS moreover are not certified and approved by NIVUS too.

Installation and/or the use of such products hence may negatively influence predetermined constructional characteristics of the measurement system or even lead to instrument failures. NIVUS cannot be held responsible for any damage resulting due to the use of non-original parts and non-original accessories.

⇒ You can find original manufacturer spare parts or accessories in chapter 8 *Accessories and Spare Parts* and/or in the valid price list.

6.8 Customer Service Information

For the recommended annual inspection of the entire measurement system and/or the extensive inspection after latest ten years contact our customer service:

NIVUS GmbH - Customer Service

Phone +49 (0) 7262 9191 - 922

customercenter@nivus.com

7 Dismantling/Disposal

Improper disposal may be harmful to the environment.

Always dispose the sensors and packaging materials according to applicable local regulations on environmental standards for electronic products

- Disconnect the measurement system from mains power.
- Remove the cables from the transmitter using appropriate tools.
- Remove the sensors from the channel bottom.



EC WEEE-Directive logo

This symbol indicates that the Directive 2012/19EG on waste electrical and electronic equipment requirements shall be observed on the disposal of the equipment.

8 Accessories and Spare Parts

Pressure compensation element ZUB0 DAE	For connection of sensors with integrated pressure measurement cell and open cable end (cable tail); Material: aluminium, plastics; Protection rating: IP54 (except filter element)
Replacement filter ZUB0 FILTER	With plug and connection hose for connecting sensors with integrated pressure measurement cell to PCM series transmitters and to the pressure compensation element ZUB0 DAE.
Dry granulate ZUB0 FILTER MAT ZUB0 FILTER MAT5	Dry gel for filling of used air filters, type ZUB0 FILTER. 1 kg (sufficient for approx. 25 refills) 200 g (sufficient for approx. 5 refills)
Spare capsules ZUB0 TROCKENK	20 Spare capsules, individually packed, for pressure compensation element of the CSM or CSP sensor

Pipe mounting system ZUB0 RMS2... ZUB0 RMS3... ZUB0 RMS4... ZUB0 RMS5...	For temporary, non-permanent clamping installation of wedge sensors POA-, CSM-, and DSM- in pipes DN 200 up to maximum DN 2000, Material: 1.4571
Sensor Adapters ZUB0 KLEMM...	Metal connection box incl. clamps for adaptation of PCM Sensors (incl. plug) to NF7 or OCM Pro transmitters (in Ex and non-Ex areas) or for connection sensor cables mit cable tail to a PCM Pro (in Ex and non-Ex areas)
Manual extraction tool ZUB0 AA	For manual removal of 1 ½" pipe sensors under process conditions, pressure-tight up to 4 bar (not suitable for installation or fastening).
Stop ball valve ZUB0 HAHN R15	For removal of pipe sensors from pipes without pressure
Tapping saddle ZUB0 ABS01... ZUB0 ABS02... ZUB0 ABS03...	For installation of 1.5" pipe sensors in pipelines
Mounting plates ZUB0 ABP15....	For installation of pipe sensors 1.5" in pipes made of GRP and concrete
Welding nozzles ZUB0 STU15...	For installation of pipe sensors 1.5" in steel or stainless steel conducts



You can find more accessories for sensor installation in our current price list.

Index

A	Accessoires87		
	Article number42		
C	Cable end configuration		
	CS2 with press. meas. cell..... 62		
	CS2 without press. meas. cell..... 62		
	Electronic box EBM..... 61		
	POA with press.meas. cell 62		
	POA without press. meas. cell 62		
	Cable extension.....63		
	Certificates and approvals.....90		
	Cleaning76		
	DSM..... 80		
	OCL..... 80		
	Pipe sensor CSM 82		
	Pipe sensors POA, CS2..... 81		
	Wedge sensors 76		
	Copyright3		
	Copyrights and property rights3		
	Customer service85		
D	Delivery.....16		
	Device identification37		
	Disclaimer.....15		
	Dismantling.....86		
	Disposal.....86		
E	Electronic box EBM		
	Specification..... 51		
	Electronic Box EBM		
	Construction..... 23		
	Type key 43		
	Electrostatic discharge57		
	Ex-Approval.....12		
I	Installation57		
	Intended use.....13		
M	Maintenance76		
	DSM..... 80		
	OCL..... 80		
	Pipe sensor CSM 82		
	Pipe sensors POA, CS2..... 81		
	Pressure compensation element		
	CSP..... 78		
	Pressure compensation element CS2..... 78		
	Pressure compensation element CSM.... 78		
	Pressure compensation element POA 78		
	Wedge sensors with press. meas. cell.... 77		
N	Nameplates37		
	Names3		
P	Personnel requirements12		
	Plug wiring		
	CS2..... 61		
	CSM..... 60		
	CSP 60		
	DSM..... 60		
	OCL 63		
	POA 61		
	Pressure compensation element.....66		
	Connect to CS2..... 70		
	Connect to POA..... 70		
	CS2..... 68		
	CSM..... 67		
	CSP 67		
	General 66		
	POA 68		
	Protection hose.....59		
	Protective clothing recommended11		
R	Reciept16		
	Return16		
S	Safety at work.....11		
	Safety devices11		
	Safety Instructions10		
	Sensor construction		
	CS2 pipe sensor 34		
	CS2 wedge sensor..... 32		
	CSM-V100K..... 19		
	CSM-V100R..... 21		
	CSM-V1D0K 20		
	CSP 36		
	DSM..... 22		
	OCL 31		
	POA pipe sensor..... 28		
	POA wedge sensor 26		
	Sensor installation58		
	Sensors		
	Overview 17		
	Versions..... 42		
	Spare parts87		
	Installation..... 84		
	Specification		
	CS2..... 54		
	CSM-V100K..... 48		
	CSM-V100R..... 50		

CSM-V1D0K	49
CSP.....	55
DSM.....	51
Electronic box EBM.....	51
OCL.....	53
POA	52
Storing	16

T

Table of Resistiveness	73
Translation.....	3
Transport	16

Type key

CS2.....	46
CSM.....	42
CSP	47
DSM.....	43
Electronic box EBM.....	43
OCL	45
POA	44

U

Users's responsibilities	14
--------------------------------	----

Certificates and approvals



Translation

(1) EC-TYPE EXAMINATION CERTIFICATE

- (2) Equipment and protective systems intended for use in potentially explosive atmospheres - **Directive 94/9/EC**
- (3) EC-Type Examination Certificate Number



TÜV 03 ATEX 2262

- (4) Equipment: Sensor type POA/... resp. OCL/...
- (5) Manufacturer: Nivus GmbH
- (6) Address: D-75031 Eppingen, Im Täle 2
- (7) This equipment or protective system and any acceptable variation thereto are specified in the schedule to this certificate and the documents therein referred to.
- (8) The TÜV NORD CERT GmbH & Co. KG, TÜV CERT-Certification Body, notified body number N° 0032 in accordance with Article 9 of the Council Directive of the EC of March 23, 1994 (94/9/EC), certifies that this equipment or protective system has been found to comply with the Essential Health and Safety Requirements relating to the design and construction of equipment and protective systems intended for use in potentially explosive atmospheres given in Annex II to the Directive.

The examination and test results are recorded in the confidential report N° 03 YEX 550797.

- (9) Compliance with the Essential Health and Safety Requirements has been assured by compliance with:

EN 50 014: 1997

EN 50 020: 2002

- (10) If the sign "X" is placed after the certificate number, it indicates that the equipment or protective system is subject to special conditions for safe use specified in the schedule to this certificate.
- (11) This EC-type examination certificate relates only to the design, examination and tests of the specified equipment in accordance to the Directive 94/9/EC. Further requirements of the Directive apply to the manufacturing process and supply of this equipment. These are not covered by this certificate.
- (12) The marking of the equipment or protective system must include the following:

 **II 2 G EEx ib IIB T4**

TÜV NORD CERT GmbH & Co. KG
TÜV CERT-Certification Body
Am TÜV 1
D-30519 Hannover
Tel.: 0511 986-1470
Fax: 0511 986-2555

Hanover, 2003-09-18

Head of the
Certification Body



TÜV CERT A4 04.02.10.000 L6

This certificate may only be reproduced without any change, schedule included.
Excerpts or changes shall be allowed by the TÜV NORD CERT GmbH & Co. KG

page 1/2



SCHEDULE

(13)

(14) **EC-TYPE EXAMINATION CERTIFICATE N° TÜV 03 ATEX 2262**

(15) Description of equipment

The sensor type POA/... resp. OCL/... is intended together with the associated measuring transformers for the measurement of the flow speed and the flow level in partly or fully filled pipes and channels via supersonic technology.

Electrical data

Signal and supply circuit
(plug/prefabricated cable)

in type of protection Intrinsic Safety EEx ib IIB
only for the connection to associated measuring
transducer type OCP/... according to TÜV 00 ATEX 1572

Maximum values: $U_i = 10.5 \text{ V}$
 $I_i = 500 \text{ mA}$

or

type PCP/... according to TÜV 03 ATEX 2268
Maximum values: $U_i = 9.9 \text{ V}$
 $I_i = 640 \text{ mA}$

The effective internal inductance and capacitance are negligibly small.

(16) Test documents are listed in the test report No.: 03 YEX 550797.

(17) Special conditions for safe use

none

(18) Essential Health and Safety Requirements

no additional ones



Translation

1. SUPPLEMENT to

EC TYPE-EXAMINATION CERTIFICATE No. TÜV 03 ATEX 2262

of the company: NIVUS GmbH
Im Täle 2
D-75031 Eppingen

In the future, the sensors type POA/... resp. OCL/... may also be manufactured and operated according to the test documents listed in the test report.

The amendments concern the electrical data.

Electrical data

Signal- and supply circuit
(plug/prefabricated cable)

in type of protection Intrinsic Safety EEx ib IIB
only for the connection to associated measuring
transducer type OCP/... according to TÜV 00 ATEX 1572
Maximum values: $U_i = 10,5 \text{ V}$
 $I_i = 640 \text{ mA}$

or

type PCP/... according to TÜV 03 ATEX 2268
Maximum values: $U_i = 9,9 \text{ V}$
 $I_i = 629 \text{ mA}$

The effective internal inductance and capacitance are
negligibly small.

All other data apply unchanged for this amendment.

Test documents are listed in the test report N° 04 YEX 551201.

TÜV NORD CERT GmbH & Co. KG
TÜV CERT-Certification Body
Am TÜV 1
D-30519 Hannover
Tel.: 0511 986-1470
Fax: 0511 986-2555

Hannover, 2004-01-30

Head of the
Certification Body

Translation
2. SUPPLEMENT

to Certificate No.	TÜV 03 ATEX 2262
Equipment:	Sensors types POA-x2xx xx E xx x x, OCL-L1 x x xx E xx K and CS2-xxxx xx E xx x x
Manufacturer:	NIVUS GmbH
Address:	Im Täle 2 75031 Eppingen, Germany
Order number:	8000555804
Date of issue:	2010-06-21

In the future, the sensors type POA/... resp. OCL/... may be produced and operated according to the documents listed in the test report.

The changes refer to

- the execution of the sensor electronics for the new sensor types
- a new dual sensor with type designation CS2-xxxx xx E xx x x in an new sensor housing with 4 ultrasonic transducers
- the changes of the origin type designations: POA-x2xx xx E xx x x and OCL-L1 x x xx E xx K
- a new RS485 interface with data for the protection level ib
- the marking.

The new marking reads: II 2 G Ex ib IIB T4

The permissible ambient temperature range of the sensors is -20 °C ... 40 °C.

Electrical data

Signal- and supply circuit (Plug in connector/cable tail connection wires: red: + blue: GND)	in type of protection Intrinsic Safety Ex ib IIB only for connection to a certified intrinsically safe circuit maximum values: $U_i = 10.5 \text{ V}$ $I_i = 640 \text{ mA}$ The connection to the following measuring transducers is permissible: type OCP/... according to TÜV 00 ATEX 1572 or type PCP/... according to TÜV 03 ATEX 2268 The effective internal capacitance and inductance of the electronics are negligibly small.
--	---

RS485 interface (Plug in connector/cable tail connection wires: white: RxTx+ green: RxTx- blue: GND)	in type of protection Intrinsic Safety Ex ib IIB maximum values: $U_o = 6 \text{ V}$ $I_o = 154 \text{ mA}$ $P_o = 230 \text{ mW}$ characteristic line: linear The effective internal capacitance and inductance of the electronics are negligibly small.
---	--

2. Supplement to Certificate No. TÜV 03 ATEX 2262

Ex ib	IIB	
max. permissible external inductance	9.5 mH	1 mH
max. permissible external capacitance	5.1 μ F	13 μ F

At connection of the RS485 interface to belonging measuring transducers with active intrinsically safe circuits, the rules for the interconnection of intrinsically safe circuits have to be observed.

maximum values:

$$U_i = 12.06 \text{ V}$$

$$I_i = 176 \text{ mA}$$

The equipment according to this supplement meets the requirements of these standards:

EN 60079-0:2006

EN 60079-11:2007

(16) The test documents are listed in the test report No. 10 203 555804.

(17) Special conditions for safe use

none

(18) Essential Health and Safety Requirements

no additional ones

TÜV NORD CERT GmbH, Langemarckstraße 20, 45141 Essen, accredited by the central office of the countries for safety engineering (ZLS), Ident. Nr. 0044, legal successor of the TÜV NORD CERT GmbH & Co. KG Ident. Nr. 0032

The head of the certification body

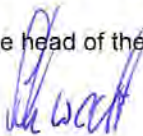

Schwedt

Hanover office, Am TÜV 1, 30519 Hanover, Tel.: +49 (0) 511 986-1455, Fax: +49 (0) 511 986-1590

Translation

3. SUPPLEMENT

to Certificate No.	TÜV 03 ATEX 2262
Equipment:	Sensors types POA-xxxx xx E xx x x, OCL-L1 x x xx E xx K and Vector Profiler CS2-xxxx xx E xx x x
Manufacturer:	NIVUS GmbH
Address:	Im Täle 2 75031 Eppingen, Germany
Order number:	8000398817
Date of issue:	2012-03-27

In the future, the sensors type POA-... bzw. OCL-... bzw. CS2-... may be produced and operated according to the documents listed in the test report.

The changes refer to

- the execution of the sensor electronics,
- a new sensor of the generation „Vector Profiler“ type CS2-xxxx Rx E xx x x,
- a new sensor type POA-xxxx Rx E xx x x
- new key sensor bodies for the sensors POA-... and
- the marking.

The new marking reads: II 2 G Ex ib IIB T4 Gb

The electrical data as well as all other details remain unchanged.

The equipment according to this supplement meets the requirements of these standards:

EN 60079-0:2009 EN 60079-11:2007

(16) The test documents are listed in the test report no. 12 203 087811.

(17) Special conditions for safe use

none

(18) Essential Health and Safety Requirements

no additional ones

TÜV NORD CERT GmbH, Langemarckstraße 20, 45141 Essen, notified by the central office of the countries for safety engineering (ZLS), Ident. Nr. 0044, legal successor of the TÜV NORD CERT GmbH & Co. KG Ident. Nr. 0032

The head of the notified body

Schwedt

Hanover office, Am TÜV 1, 30519 Hanover, Tel.: +49 (0) 511 986-1455, Fax: +49 (0) 511 986-1590

Translation
4. SUPPLEMENT

to Certificate No. Equipment:	TÜV 03 ATEX 2262 Sensors types POA-x2xx xx E xx x x, OCL-L1 x x xx E xx K and CS2-xxxx xx E xx x x
Manufacturer: Address:	NIVUS GmbH Im Täle 2 75031 Eppingen
Order number: Date of issue:	8000442088 2015-06-11

In the future, the sensors types

POA-x2xx xx E xx x x
 OCL-L1 x x xx E xx K and
 CS2-xxxx xx E xx x x

may also be manufactured and operated according to the documents listed in the test report.
 The changes refer to

- changes in the layout and regarding components,
- constructional changes at the housings and
- the electrical data.

A standard update was performed.

Electrical data

Signal and supply circuit in type of protection Intrinsic Safety Ex ib IIB
 (Cable tail); only for connection to a certified intrinsically safe circuit
 connection wires: Maximum values:
 red [+], blue [GND] $U_i = 10.5 \text{ V}$

$I_i = 640 \text{ mA}$
 $P_i = 6.72 \text{ W}$

The connection to the following measuring transducers
 is permissible:

type OCP-... according to TÜV 00 ATEX 1572 or
 type PCP-E... according to TÜV 03 ATEX 2268 or
 type IXT0-... according to TÜV 14 ATEX 142076

The effective internal capacitance and inductance of the
 electronics are negligibly small.

RS485 interface in type of protection Intrinsic Safety Ex ib IIB
 (Cable tail); maximum values:

$U_o = 6 \text{ V}$
 $I_o = 81.9 \text{ mA}$ (long time; for calculation of P_o)
 $I_o = 154 \text{ mA}$ (short time; for calculation of L_o, C_o)
 $P_o = 123 \text{ mW}$

characteristic line: linear

The effective internal capacitance and inductance of the
 electronics are negligibly small.

4. Supplement to Certificate No. TÜV 03 ATEX 2262

Ex ib	IIB	
max. permissible external inductance	9.5 mH	1 mH
max. permissible external capacitance	5.1 μ F	13 μ F

At connection of the RS485 interface to belonging measuring transducers with active intrinsically safe circuits, the rules for the interconnection of intrinsically safe circuits have to be observed.

maximum values:

$$U_i = 12.06 \text{ V}$$

$$I_i = 176 \text{ mA}$$

$$P_i = 531 \text{ mW}$$

All other data apply unchanged.

The equipment incl. of this supplement meets the requirements of these standards:

EN 60079-0:2012

EN 60079-11:2012

(16) The test documents are listed in the test report No. 15 203 123378.

(17) Special conditions for safe use

none

(18) Essential Health and Safety Requirements

no additional ones

TÜV NORD CERT GmbH, Langemarckstraße 20, 45141 Essen, notified by the central office of the countries for safety engineering (ZLS), Ident. Nr. 0044, legal successor of the TÜV NORD CERT GmbH & Co. KG Ident. Nr. 0032

The head of the notified body



Meyer

Hanover office, Am TÜV 1, 30519 Hannover, Tel.: +49 (0) 511 986-1455, Fax: +49 (0) 511 986-1590



IECEX Certificate of Conformity

INTERNATIONAL ELECTROTECHNICAL COMMISSION IEC Certification Scheme for Explosive Atmospheres

for rules and details of the IECEx Scheme visit www.iecex.com

Certificate No.:	IECEX TUN 15.0014	issue No.:1	Certificate history: Issue No. 1 (2015-7-24) Issue No. 0 (2015-6-11)
Status:	Current		
Date of Issue:	2015-07-24	Page 1 of 4	
Applicant:	NIVUS GmbH Im Tale 2 75031 Eppingen Germany		
Electrical Apparatus: <i>Optional accessory:</i>	Sensors type POA-..., OCL-L1... and CS2-... (see below)		
Type of Protection:	Intrinsic safety		
Marking:	Ex ib IIB T4 Gb		
Approved for issue on behalf of the IECEx Certification Body:	Andreas Meyer		
Position:	Head of IECEx Certification Body		
Signature: (for printed version)			
Date:	<u>2015-07-24</u>		

1. This certificate and schedule may only be reproduced in full.
2. This certificate is not transferable and remains the property of the issuing body.
3. The Status and authenticity of this certificate may be verified by visiting the Official IECEx Website.

Certificate issued by:

TÜV NORD CERT GmbH
 Hanover Office
 Am TÜV 1
 30519 Hannover
 Germany





IECEx Certificate of Conformity

Certificate No.: IECEx TUN 15.0014

Date of Issue: 2015-07-24

Issue No.: 1

Page 2 of 4

Manufacturer: **NIVUS GmbH**
Im Täle 2
75031 Eppingen
Germany

Additional Manufacturing location
(s):

This certificate is issued as verification that a sample(s), representative of production, was assessed and tested and found to comply with the IEC Standard list below and that the manufacturer's quality system, relating to the Ex products covered by this certificate, was assessed and found to comply with the IECEx Quality system requirements. This certificate is granted subject to the conditions as set out in IECEx Scheme Rules, IECEx 02 and Operational Documents as amended.

STANDARDS:

The electrical apparatus and any acceptable variations to it specified in the schedule of this certificate and the identified documents, was found to comply with the following standards:

IEC 60079-0 : 2011 Explosive atmospheres - Part 0: General requirements
Edition: 6.0

IEC 60079-11 : 2011 Explosive atmospheres - Part 11: Equipment protection by intrinsic safety "I"
Edition: 6.0

*This Certificate **does not** indicate compliance with electrical safety and performance requirements other than those expressly included in the Standards listed above.*

TEST & ASSESSMENT REPORTS:

A sample(s) of the equipment listed has successfully met the examination and test requirements as recorded in

Test Report:
DE/TUN/EXTR15.0032/00

Quality Assessment Report:
DE/TUN/QAR13.0011/01



IECEX Certificate of Conformity

Certificate No.: IECEx TUN 15.0014

Date of Issue: 2015-07-24

Issue No.: 1

Page 3 of 4

Schedule

EQUIPMENT:

Equipment and systems covered by this certificate are as follows:

Together with the associated measuring transformers the sensors type

POA-x2xx xx E xx x x

OCL-L1 x x xx E xx K and

CS2-xxxx xx E xx x x

are intended for measurement of the flow speed and the flow level in partly or fully filled pipes and channels via supersonic technology.

The permissible ambient temperature range of the sensors is -20 °C ... 40 °C.

See annexe for further information

CONDITIONS OF CERTIFICATION: NO



IECEx Certificate of Conformity

Certificate No.: IECEx TUN 15.0014

Date of Issue: 2015-07-24

Issue No.: 1

Page 4 of 4

DETAILS OF CERTIFICATE CHANGES (for issues 1 and above):

Purpose of this issue no. 1 was to correct a fault on page 1.
The correct marking is:
Ex ib IIB T4 Gb
No other changes were done.

Annex: Annexe_COC_POA_OCL_CS2.pdf

The system sensor family Mini consists of the following components:

- Electronic Box Mini type **EBM**
- Correlation Sensor Mini type **CSM** and **CSM-D**
- Distance Sensor Mini type **DSM**



Translation

(1) **EU-Type Examination Certificate**

(2) Equipment and protective systems intended for use in potentially explosive atmospheres, **Directive 2014/34/EU**



(3) **Certificate Number** TÜV 12 ATEX 087812 **issue:** 01
(4) for the product: System "Sensor Family Mini" consisting of the components according to schedule
(5) of the manufacturer: NIVUS GmbH
(6) Address: Im Tåle 2
75031 Eppingen
Order number: 8003004431
Date of issue: 2019-04-02

- (7) The design of this product and any acceptable variation thereto are specified in the schedule to this EU-Type Examination Certificate and the documents therein referred to.
- (8) The TÜV NORD CERT GmbH, Notified Body No. 0044, in accordance with Article 17 of the Directive 2014/34/EU of the European Parliament and the Council of 26 February 2014, certifies that this product has been found to comply with the Essential Health and Safety Requirements relating to the design and construction of products intended for use in potentially explosive atmospheres given in Annex II to the Directive.
The examination and test results are recorded in the confidential ATEX Assessment Report No. 19 203 242039.
- (9) Compliance with the Essential Health and Safety Requirements has been assured by compliance with:
EN 60079-0:2012+A11:2013 EN 60079-11:2012
except in respect of those requirements listed at item 18 of the schedule.
- (10) If the sign "X" is placed after the certificate number, it indicates that the product is subject to the Specific Conditions for Use specified in the schedule to this certificate.
- (11) This EU-Type Examination Certificate relates only to the design, and construction of the specified product. Further requirements of the Directive apply to the manufacturing process and supply of this equipment. These are not covered by this certificate.
- (12) The marking of the product shall include the following:

II 2 G Ex ib IIB T4 Gb

TÜV NORD CERT GmbH, Langemarckstraße 20, 45141 Essen, notified by the central office of the countries for safety engineering (ZLS), Ident. Nr. 0044, legal successor of the TÜV NORD CERT GmbH & Co. KG Ident. Nr. 0032

The head of the notified body

Roder

Hanover office, Am TÜV 1, 30519 Hannover, Tel. +49 511 998-61455, Fax +49 511 998-61590

This certificate may only be reproduced without any change, schedule included.
Excerpts or changes shall be allowed by the TÜV NORD CERT GmbH

(13) **SCHEDULE**

(14) **EU-Type Examination Certificate No. TÜV 12 ATEX 087812 issue 01**

(15) Description of product

In conjunction with the belonging measuring transducers resp. Ex-Separator-Module, the system "Sensor Family Mini" is used for measurement of the flow speed and the flow level in partly or fully filled pipes and channels via supersonic technology.

The system "Sensor Family Mini" consists of the following components:

Electronic Box Mini type EBM

Sensors type

correlation sensor CSM-V100, CSM-V1D0,

CSM-V100Rx, CSP-V2xx,

distance sensor DSM-L0 and level sensor OCL-LM,

clamp-on sensor NIC-CO,

transit time sensor NIS0 V200, TSP0 V200, NIS-V200 und NIS-V280

The permissible ambient temperature range is:

For EBM: -20 °C ... 40 °C

For all sensors: -40 °C ... 80 °C

Electrical data

Signal and supply circuit (of EBM) in type of protection Intrinsic Safety Ex ib IIB
(Connection wires (pig tail): only for connection to a certified intrinsically safe circuit
red [+], blue [GND])

Maximum values:

$$U_i = 10.5 \text{ V}$$

$$I_i = 640 \text{ mA}$$

$$P_i = 6.72 \text{ W}$$

The connection to the following measuring transducers of the manufacturer is permissible:

type OCP-...

type PCP-E...

The connection to the following Ex-Separator-Module is permissible:

type iXT0 xxx

The effective internal capacitance and inductance of the electronics are negligibly small.

The capacitances and inductances of the connected cable have to be taken into account.

Schedule to EU-Type Examination Certificate No. TÜV 12 ATEX 087812 issue 01

Interface RS485 (of EBM) in type of protection Intrinsic Safety Ex ib IIB
 (Connection wires (pig tail):
 white [RxTx+]
 green [RxTx-]
 blue: GND)

Maximum values:
 $U_o = 6 \text{ V}$
 $I_o = 81.9 \text{ mA}$
 Angle current: 50 mA
 Angle voltage: 4 V
 $P_o = 200 \text{ mW}$
 Characteristic line: angular
 The effective internal capacitance and inductance of the electronics are negligibly small.

Ex ib	IIB	
max. permissible external inductance	10 mH	1 mH
max. permissible external capacitance	3.8 μF	11.2 μF

At connection of the interface RS485 to belonging measuring transducers with active intrinsically safe circuits, the rules for interconnection of intrinsically safe circuits have to be taken into account.

Maximum values:
 $U_i = 12.06 \text{ V}$
 $I_i = 176 \text{ mA}$
 $P_i = 531 \text{ mW}$

The interconnection of the electronic box Mini type EBM with the sensors

- Correlation sensor Mini type CSM-V100 or CSM-V1D0 or CSM-V100Rx or CSP-V2xx and
- Distance sensor Mini type DSM (or filling level sensor type OCL-LM)

via a cable of the manufacturer with a length of 20 m is permissible.

Piezo connections in type of protection Intrinsic Safety Ex ib IIB
 (Connector Pins A/B or C/D)
 Only for connection to the intrinsically safe circuits of the devices "Electronic Box Mini" EBM or the "NivuFlow Mobile" NFM of the manufacturer with safe energy limitation
 $C_i = 11 \text{ nF}$
 $L_i = 12 \mu\text{H}$

1-Wire temperature sensor,
 1-Wire EEPROM in type of protection Intrinsic Safety Ex ib IIB
 (Connector Pins E, F and J)
 Only for connection to an intrinsically safe circuit
 $U_i = 6 \text{ V}$
 $I_i = 188 \text{ mA}$
 $P_i = 282 \text{ mW}$
 $C_i = 120 \text{ nF}$
 The effective internal inductance is negligibly small.

Schedule to EU-Type Examination Certificate No. TÜV 12 ATEX 087812 issue 01

Pressure cell in type of protection Intrinsic Safety Ex ib IIB
(Connector Pins E, G, H and J) Only for connection to an intrinsically safe circuit
 $U_i = 6 \text{ V}$
 $I_i = 264 \text{ mA}$
 $P_i = 396 \text{ mW}$
 $C_i = 20.15 \mu\text{F}$
The effective internal inductance is negligibly small.

Details of Change:

The type designations for some sensors were changed. No technical changes were performed.

(16) Drawings and documents are listed in the ATEX Assessment Report No. 19 203 232039

(17) Specific Conditions for Use

none

(18) Essential Health and Safety Requirements

no additional ones

- End of Certificate -



IECEX Certificate of Conformity

INTERNATIONAL ELECTROTECHNICAL COMMISSION
IEC Certification Scheme for Explosive Atmospheres

for rules and details of the IECEx Scheme visit www.iecex.com

Certificate No.: IECEx TUN 18.0023 Issue No: 1 Certificate history:
Issue No. 1 (2019-06-10)
Issue No. 0 (2018-11-20)

Status: Current Page 1 of 4

Date of Issue: 2019-06-10

Applicant: NIVUS GmbH
Im Töle 2
76031 Eppingen
Germany

Equipment: System "Sensor Family Mini"; see schedule for details
Optional accessory:

Type of Protection: Intrinsic Safety "i"

Marking: Ex ib IIB T4 Gb

Approved for issue on behalf of the IECEx
Certification Body:

Christian Roder

Position:

Head of IECEx Certification Body

Signature:
(for printed version)

Date:

1. This certificate and schedule may only be reproduced in full.
2. This certificate is not transferable and remains the property of the issuing body.
3. The Status and authenticity of this certificate may be verified by visiting the Official IECEx Website.

Certificate issued by:

TÜV NORD CERT GmbH
Hanover Office
Am TÜV 1, 30619 Hannover
Germany





IECEX Certificate of Conformity

Certificate No: IECEx TUN 18.0023 Issue No: 1
Date of Issue: 2019-06-10 Page 2 of 4
Manufacturer: NIVUS GmbH
Im Täl 2
75031 Eppingen
Germany

Additional Manufacturing location(s):

This certificate is issued as verification that a sample(s), representative of production, was assessed and tested and found to comply with the IEC Standard list below and that the manufacturer's quality system, relating to the Ex products covered by this certificate, was assessed and found to comply with the IECEx Quality System requirements. This certificate is granted subject to the conditions as set out in IECEx Scheme Rules, IECEx 02 and Operational Documents as amended.

STANDARDS:

The apparatus and any acceptable variations to it specified in the schedule of this certificate and the identified documents, was found to comply with the following standards:

IEC 60079-0 : 2011 Explosive atmospheres - Part 0: General requirements
Edition:5.0
IEC 60079-11 : 2011 Explosive atmospheres - Part 11: Equipment protection by intrinsic safety 'T'
Edition:5.0

This Certificate does not indicate compliance with electrical safety and performance requirements other than those expressly included in the Standards listed above.

TEST & ASSESSMENT REPORTS:

A sample(s) of the equipment listed has successfully met the examination and test requirements as recorded in

Test Report:

DE/TUN/ExTR18.0026/01

Quality Assessment Report:

DE/TUN/QAR13.0011/05



IECEX Certificate of Conformity

Certificate No: IECEX TUN 18.0023

Issue No: 1

Date of Issue: 2019-05-10

Page 3 of 4

Schedule

EQUIPMENT:

Equipment and systems covered by this certificate are as follows:

In conjunction with the belonging measuring transducers resp. Ex-Separator-Module, the system "Sensor Family Mini" is used for measurement of the flow speed and the flow level in partly or fully filled pipes and channels via supersonic technology.

The system "Sensor Family Mini" consists of the following components:

Electronic Box Mini type EBM

Sensors type

correlation sensor CSM-V100, CSM-V1D0,

CSM-V100Rx, CSP-V2xx,

distance sensor DSM-L0 and level sensor OCL-LM,

clamp-on sensor NIC-CO,

transit time sensor NIS0 V200, TSP0 V200, NIS-V200 and NIS-V280

The permissible ambient temperature range is:

For EBM: -20 °C ... 40 °C

For all sensors: -40 °C ... 80 °C

For further details see attachment.

SPECIFIC CONDITIONS OF USE: NO



IECEX Certificate of Conformity

Certificate No: IECEx TUN 18.0023

Issue No: 1

Date of Issue: 2019-05-10

Page 4 of 4

DETAILS OF CERTIFICATE CHANGES (for issues 1 and above):

The type designations for some sensors were changed. No technical changes were performed.

Annex:

[_Attachment_Sensorfamily Mini_01.pdf](#)

Product:

In conjunction with the belonging measuring transducers resp. Ex-Separator-Module, the system "Sensor Family Mini" is used for measurement of the flow speed and the flow level in partly or fully filled pipes and channels via supersonic technology.

The system "Sensor Family Mini" consists of the following components:

Electronic Box Mini type EBM
Sensors type correlation sensor CSM-V100, CSM-V1D0,
CSM-V100Rx, CSP-V2xx,
distance sensor DSM-L0 and level sensor OCL-LM,
clamp-on sensor NIC-CO,
transit time sensor NIS0 V200, TSP0 V200, NIS-V200 and NIS-V280

The permissible ambient temperature range is:

For EBM: -20 °C ... 40 °C

For all sensors: -40 °C ... 80 °C

Electrical data

Signal and supply circuit (of EBM) (Connection wires (pig tail): red [+], blue [GND])	in type of protection Intrinsic Safety Ex ib IIB only for connection to a certified intrinsically safe circuit. Maximum values: $U_i = 10.5 \text{ V}$ $I_i = 640 \text{ mA}$ $P_i = 6.72 \text{ W}$ The connection to the following measuring transducers of the manufacturer is permissible: type OCP-... type PCP-E... The connection to the following Ex-Separator-Module is permissible: type iXT0 xxx The effective internal capacitance and inductance of the electronics are negligibly small. The capacitances and inductances of the connected cable have to be taken into account.
Interface RS485 (of EBM) (Connection wires (pig tail): white [RxTx+] green [RxTx-] blue: GND)	in type of protection Intrinsic Safety Ex ib IIB Maximum values: $U_o = 6 \text{ V}$ $I_o = 81.9 \text{ mA}$ Angle current: 50 mA Angle voltage: 4 V $P_o = 200 \text{ mW}$ Characteristic line: angular The effective internal capacitance and inductance of the electronics are negligibly small.

Ex ib	IIB	
max. permissible external inductance	10 mH	1 mH
max. permissible external capacitance	3.8 µF	11.2 µF

At connection of the interface RS485 to belonging measuring transducers with active intrinsically safe circuits, the rules for interconnection of intrinsically safe circuits have to be taken into account.

Maximum values:

$$U_i = 12.06 \text{ V}$$

$$I_i = 176 \text{ mA}$$

$$P_i = 531 \text{ mW}$$

The interconnection of the electronic box Mini type EBM with the sensors

- Correlation sensor Mini type CSM-V100 or CSM-V1D0 or CSM-V100Rx or CSP-V2xx and
- Distance sensor Mini type DSM (or filling level sensor type OCL-LM)

via a cable of the manufacturer with a length of 20 m is permissible.

Piezo connections in type of protection Intrinsic Safety Ex ib IIB
(Connector Pins A/B or C/D) Only for connection to the intrinsically safe circuits of the devices "Electronic Box Mini" EBM or the "NivuFlow Mobile" NFM of the manufacturer with safe energy limitation
 $C_i = 11 \text{ nF}$
 $L_i = 12 \text{ µH}$

1-Wire temperature sensor,
1-Wire EEPROM in type of protection Intrinsic Safety Ex ib IIB
(Connector Pins E, F and J) Only for connection to an intrinsically safe circuit
 $U_i = 6 \text{ V}$
 $I_i = 188 \text{ mA}$
 $P_i = 282 \text{ mW}$
 $C_i = 120 \text{ nF}$
The effective internal inductance is negligibly small.

Pressure cell in type of protection Intrinsic Safety Ex ib IIB
(Connector Pins E, G, H and J) Only for connection to an intrinsically safe circuit
 $U_i = 6 \text{ V}$
 $I_i = 264 \text{ mA}$
 $P_i = 396 \text{ mW}$
 $C_i = 20.15 \text{ µF}$
The effective internal inductance is negligibly small.

Details of Change:

The type designations for some sensors were changed. No technical changes were performed.

Special Conditions for Safe Use / Notes for Erection:

-none-

EU Konformitätserklärung

EU Declaration of Conformity

Déclaration de conformité UE

NIVUS GmbH
Im Täle 2
75031 Eppingen

Telefon: +49 07262 9191-0
Telefax: +49 07262 9191-999
E-Mail: info@nivus.com
Internet: www.nivus.de

Für das folgend bezeichnete Erzeugnis:

For the following product:

Le produit désigné ci-dessous:

Bezeichnung:	Ultraschallsensoren CSM / CSP / DSM / OCL-LM
<i>Description:</i>	<i>Ultrasonic sensors</i>
<i>Désignation:</i>	<i>Capteurs ultrasoniques</i>
Typ / Type:	CSM-V100K... / CSM-V1D0K... / CSM-V100R... / CSP-V2... / DSM-L0... / OCL-LM...

erklären wir in alleiniger Verantwortung, dass die auf dem Unionsmarkt ab dem Zeitpunkt der Unterzeichnung bereitgestellten Geräte die folgenden einschlägigen Harmonisierungsvorschriften der Union erfüllen:

we declare under our sole responsibility that the equipment made available on the Union market as of the date of signature of this document meets the standards of the following applicable Union harmonisation legislation:

nous déclarons, sous notre seule responsabilité, à la date de la présente signature, la conformité du produit pour le marché de l'Union, aux directives d'harmonisation de la législation au sein de l'Union:

- 2014/30/EU
- 2011/65/EU

Bei der Bewertung wurden folgende einschlägige harmonisierte Normen zugrunde gelegt bzw. wird die Konformität erklärt in Bezug die nachfolgend genannten anderen technischen Spezifikationen:

The evaluation assessed the following applicable harmonised standards or the conformity is declared in relation to other technical specifications listed below:

L'évaluation est effectuée à partir des normes harmonisées applicable ou la conformité est déclarée en relation aux autres spécifications techniques désignées ci-dessous:

- EN 61326-1:2013

Diese Erklärung wird verantwortlich für den Hersteller:

This declaration is submitted on behalf of the manufacturer:

Le fabricant assume la responsabilité de cette déclaration:

NIVUS GmbH
Im Taele 2
75031 Eppingen
Allemagne

abgegeben durch / *represented by / faite par:*

Marcus Fischer (Geschäftsführer / *Managing Director / Directeur général*)

Eppingen, den 21.11.2018

Gez. *Marcus Fischer*

UK Declaration of Conformity

NIVUS GmbH
Im Tale 2
75031 Eppingen

Telefon: +49 07262 9191-0
Telefax: +49 07262 9191-999
E-Mail: info@nivirus.com
Internet: www.nivirus.de

For the following product:

Description:	Ultrasonic sensors CSM / CSP / DSM / OCL-LM
Type:	CSM-V100K... / CSM-V1D0K... / CSM-V100R... / CSP-V2... / DSM-L0... / OCL-LM...

we declare under our sole responsibility that the equipment made available on the UK market as of the date of signature of this document meets the standards of the following applicable UK harmonisation legislation:

- SI 2016 / 1091 The Electromagnetic Compatibility Regulations 2016
- SI 2012 / 3032 The Restriction of the Use of Certain Hazardous Substances in Electrical and Electronic Equipment Regulations 2012

The evaluation assessed the following applicable harmonised standards or the conformity is declared in relation to other technical specifications listed below:

- BS EN 61326-1:2013

This declaration is submitted on behalf of the manufacturer:

NIVUS GmbH
Im Taele 2
75031 Eppingen
Germany

represented by:

Ingrid Steppe (Managing Director)

Eppingen, 20/10/2022

Signed by *Ingrid Steppe*

EU Konformitätserklärung

EU Declaration of Conformity

Déclaration de conformité UE

Für das folgend bezeichnete Erzeugnis:

For the following product:

Le produit désigné ci-dessous:

Bezeichnung:	"Ex" Ultraschallsensoren CSM / CSP / DSM / OCL-LM
<i>Description:</i>	<i>"Ex" ultrasonic sensors</i>
<i>Désignation:</i>	<i>"Ex" capteurs ultrasoniques</i>
Typ / Type:	CSM-V100KxE... / CSM-V1D0KxE... / CSM-V100Rx... / CSP-V2xxxxE... / DSM-L0xxxxE... / OCL-LMxxxxE...

erklären wir in alleiniger Verantwortung, dass die auf dem Unionsmarkt ab dem Zeitpunkt der Unterzeichnung bereitgestellten Geräte die folgenden einschlägigen Harmonisierungsvorschriften der Union erfüllen:

we declare under our sole responsibility that the equipment made available on the Union market as of the date of signature of this document meets the standards of the following applicable Union harmonisation legislation:

nous déclarons, sous notre seule responsabilité, à la date de la présente signature, la conformité du produit pour le marché de l'Union, aux directives d'harmonisation de la législation au sein de l'Union:

- 2014/30/EU
- 2014/34/EU
- 2011/65/EU

Bei der Bewertung wurden folgende einschlägige harmonisierte Normen zugrunde gelegt bzw. wird die Konformität erklärt in Bezug auf die nachfolgend genannten anderen technischen Spezifikationen:

The evaluation assessed the following applicable harmonised standards or the conformity is declared in relation to other technical specifications listed below:

L'évaluation est effectuée à partir des normes harmonisées applicable ou la conformité est déclarée en relation aux autres spécifications techniques désignées ci-dessous:

- EN 61326-1:2013
- EN IEC 60079-0:2018
- EN 60079-11:2012

Ex-Kennzeichnung / *Ex-designation* / *Marquage Ex* :

 II 2G Ex ib IIB T4 Gb

EU-Baumusterprüfbescheinigung / *EU-Type Examination Certificate* / *Attestation d'examen «UE» de type:*

TÜV 12 ATEX 087812 ISSUE: 01

Notifizierte Stelle (Kennnummer) / *Notified Body (Identif. No.)* / *Organisme notifié (N° d'identification)*

TÜV Nord CERT GmbH, Am TÜV 1, 45307 Essen, Germany

(0044)

Diese Erklärung wird verantwortlich für den Hersteller:

This declaration is submitted on behalf of the manufacturer:

Le fabricant assume la responsabilité de cette déclaration:

NIVUS GmbH
Im Täle 2
75031 Eppingen
Germany

abgegeben durch / *represented by* / *faite par:*

Ingrid Steppe (Geschäftsführerin / *Managing Director* / *Directeur général*)

Eppingen, den 19.10.2022

Gez. *Ingrid Steppe*

UK Declaration of Conformity

NIVUS GmbH
Im Tale 2
75031 Eppingen

Telefon: +49 07262 9191-0
Telefax: +49 07262 9191-999
E-Mail: info@nivus.com
Internet: www.nivus.de

For the following product:

Description:	"Ex" ultrasonic sensors
Type:	CSM-V100KxE... / CSM-V1D0KxE... / CSM-V100RxE... / CSP-V2xxxxE... / DSM-L0xxxxE... / OCL-LMxxxxE...

we declare under our sole responsibility that the equipment made available on the UK market as of the date of signature of this document meets the standards of the following applicable UK harmonisation legislation:

- SI 2016 / 1091 The Electromagnetic Compatibility Regulations 2016
- SI 2016 / 1107 The Equipment and Protective Systems Intended for use in Potentially Explosive Atmospheres Regulations 2016
- SI 2012 / 3032 The Restriction of the Use of Certain Hazardous Substances in Electrical and Electronic Equipment Regulations 2012

The evaluation assessed the following applicable harmonised standards or the conformity is declared in relation to other technical specifications listed below:

- BS EN 61326-1:2013
- BS EN IEC 60079-0:2018
- BS EN 60079-11:2012

Ex-designation:



II 2G Ex ib IIB T4 Gb

EU-Type Examination Certificate:

TÜV 12 ATEX 087812 ISSUE: 01

Notified Body (Identif. No.):

TÜV Nord CERT GmbH, Am TÜV 1, 45307 Essen, Germany

(0044)

This declaration is submitted on behalf of the manufacturer:

NIVUS GmbH
Im Taele 2
75031 Eppingen
Germany

represented by:

Ingrid Steppe (Managing Director)

Eppingen, 20/10/2022

Signed by *Ingrid Steppe*

EU Konformitätserklärung

EU Declaration of Conformity

Déclaration de conformité UE

NIVUS GmbH
Im Täle 2
75031 Eppingen

Telefon: +49 07262 9191-0
Telefax: +49 07262 9191-999
E-Mail: info@nivus.com
Internet: www.nivus.de

Für das folgend bezeichnete Erzeugnis:

For the following product:

Le produit désigné ci-dessous:

Bezeichnung:	Externe Elektronikbox EBM
<i>Description:</i>	<i>external electronic Box</i>
<i>Désignation:</i>	<i>boîtier électronique externe</i>
Typ / Type:	EBM-...

erklären wir in alleiniger Verantwortung, dass die auf dem Unionsmarkt ab dem Zeitpunkt der Unterzeichnung bereitgestellten Geräte die folgenden einschlägigen Harmonisierungsvorschriften der Union erfüllen:

we declare under our sole responsibility that the equipment made available on the Union market as of the date of signature of this document meets the standards of the following applicable Union harmonisation legislation:

nous déclarons, sous notre seule responsabilité, à la date de la présente signature, la conformité du produit pour le marché de l'Union, aux directives d'harmonisation de la législation au sein de l'Union:

- 2014/30/EU
- 2011/65/EU

Bei der Bewertung wurden folgende einschlägige harmonisierte Normen zugrunde gelegt bzw. wird die Konformität erklärt in Bezug die nachfolgend genannten anderen technischen Spezifikationen:

The evaluation assessed the following applicable harmonised standards or the conformity is declared in relation to other technical specifications listed below:

L'évaluation est effectuée à partir des normes harmonisées applicable ou la conformité est déclarée en relation aux autres spécifications techniques désignées ci-dessous:

- EN 61326-1:2013

Diese Erklärung wird verantwortlich für den Hersteller:

This declaration is submitted on behalf of the manufacturer:

Le fabricant assume la responsabilité de cette déclaration:

NIVUS GmbH
Im Täle 2
75031 Eppingen
Allemagne

abgegeben durch / *represented by / faite par:*

Marcus Fischer (Geschäftsführer / *Managing Director / Directeur général*)

Eppingen, den 20.04.2016

Gez. *Marcus Fischer*

UK Declaration of Conformity

NIVUS GmbH
Im Tale 2
75031 Eppingen

Telefon: +49 07262 9191-0
Telefax: +49 07262 9191-999
E-Mail: info@nivus.com
Internet: www.nivus.de

For the following product:

Description:	External electronic Box
Type:	EBM-...

we declare under our sole responsibility that the equipment made available on the UK market as of the date of signature of this document meets the standards of the following applicable UK harmonisation legislation:

- SI 2016 / 1091 The Electromagnetic Compatibility Regulations 2016
- SI 2012 / 3032 The Restriction of the Use of Certain Hazardous Substances in Electrical and Electronic Equipment Regulations 2012

The evaluation assessed the following applicable harmonised standards or the conformity is declared in relation to other technical specifications listed below:

- BS EN 61326-1:2013

This declaration is submitted on behalf of the manufacturer:

NIVUS GmbH
Im Taele 2
75031 Eppingen
Germany

represented by:

Ingrid Steppe (Managing Director)

Eppingen, 20/10/2022

Signed by *Ingrid Steppe*

EU Konformitätserklärung

EU Declaration of Conformity

Déclaration de conformité UE

Für das folgend bezeichnete Erzeugnis:

For the following product:

Le produit désigné ci-dessous:

Bezeichnung:	"Ex" Externe Elektronikbox EBM
<i>Description:</i>	<i>"Ex" external electronic Box</i>
<i>Désignation:</i>	<i>"Ex" boîtier électronique externe</i>
Typ / Type:	EBM-xxxxxxE...

erklären wir in alleiniger Verantwortung, dass die auf dem Unionsmarkt ab dem Zeitpunkt der Unterzeichnung bereitgestellten Geräte die folgenden einschlägigen Harmonisierungsvorschriften der Union erfüllen:

we declare under our sole responsibility that the equipment made available on the Union market as of the date of signature of this document meets the standards of the following applicable Union harmonisation legislation:

nous déclarons, sous notre seule responsabilité, à la date de la présente signature, la conformité du produit pour le marché de l'Union, aux directives d'harmonisation de la législation au sein de l'Union:

- 2014/30/EU
- 2014/34/EU
- 2011/65/EU

Bei der Bewertung wurden folgende einschlägige harmonisierte Normen zugrunde gelegt bzw. wird die Konformität erklärt in Bezug auf die nachfolgend genannten anderen technischen Spezifikationen:

The evaluation assessed the following applicable harmonised standards or the conformity is declared in relation to other technical specifications listed below:

L'évaluation est effectuée à partir des normes harmonisées applicable ou la conformité est déclarée en relation aux autres spécifications techniques désignées ci-dessous:

- EN 61326-1:2013
- EN IEC 60079-0:2018
- EN 60079-11:2012

Ex-Kennzeichnung / *Ex-designation* / *Marquage Ex* :

 II 2G Ex ib IIB T4 Gb

EU-Baumusterprüfbescheinigung / *EU-Type Examination Certificate* / *Attestation d'examen «UE» de type:*

TÜV 12 ATEX 087812 ISSUE: 01

Notifizierte Stelle (Kennnummer) / *Notified Body (Identif. No.)* / *Organisme notifié (Nº d'identification)*

TÜV Nord CERT GmbH, Am TÜV 1, 45307 Essen, Germany

(0044)

Diese Erklärung wird verantwortlich für den Hersteller:

This declaration is submitted on behalf of the manufacturer:

Le fabricant assume la responsabilité de cette déclaration:

NIVUS GmbH
Im Täle 2
75031 Eppingen
Germany

abgegeben durch / *represented by* / *faite par:*

Ingrid Steppe (Geschäftsführerin / *Managing Director* / *Directeur général*)

Eppingen, den 19.10.2022

Gez. *Ingrid Steppe*

UK Declaration of Conformity

NIVUS GmbH
Im Täle 2
75031 Eppingen

Telefon: +49 07262 9191-0
Telefax: +49 07262 9191-999
E-Mail: info@nivus.com
Internet: www.nivus.de

For the following product:

Description: "Ex" external electronic Box

Type: EBM-xxxxxxE...

we declare under our sole responsibility that the equipment made available on the UK market as of the date of signature of this document meets the standards of the following applicable UK harmonisation legislation:

- SI 2016 / 1091 The Electromagnetic Compatibility Regulations 2016
- SI 2016 / 1107 The Equipment and Protective Systems Intended for use in Potentially Explosive Atmospheres Regulations 2016
- SI 2012 / 3032 The Restriction of the Use of Certain Hazardous Substances in Electrical and Electronic Equipment Regulations 2012

The evaluation assessed the following applicable harmonised standards or the conformity is declared in relation to other technical specifications listed below:

- BS EN 61326-1:2013
- BS EN IEC 60079-0:2018
- BS EN 60079-11:2012

Ex-designation:



II 2G Ex ib IIB T4 Gb

EU-Type Examination Certificate:

TÜV 12 ATEX 087812 ISSUE: 01

Notified Body (Identif. No.):

TÜV Nord CERT GmbH, Am TÜV 1, 45307 Essen, Germany

(0044)

This declaration is submitted on behalf of the manufacturer:

NIVUS GmbH
Im Täle 2
75031 Eppingen
Germany

represented by:

Ingrid Steppe (Managing Director)

Eppingen, 20/10/2022

Signed by *Ingrid Steppe*

EU Konformitätserklärung

EU Declaration of Conformity

Déclaration de conformité UE

NIVUS GmbH
Im Täle 2
75031 Eppingen

Telefon: +49 07262 9191-0
Telefax: +49 07262 9191-999
E-Mail: info@nivus.com
Internet: www.nivus.de

Für das folgend bezeichnete Erzeugnis:

For the following product:

Le produit désigné ci-dessous:

Bezeichnung:	Ultraschall-Aktivsensoren POA / OCL / CS2
<i>Description:</i>	<i>Ultrasonic active sensors</i>
<i>Désignation:</i>	<i>Capteurs actifs ultrasoniques</i>
Typ / Type:	POA-... / OCL-... / CS2-...

erklären wir in alleiniger Verantwortung, dass die auf dem Unionsmarkt ab dem Zeitpunkt der Unterzeichnung bereitgestellten Geräte die folgenden einschlägigen Harmonisierungsvorschriften der Union erfüllen:

we declare under our sole responsibility that the equipment made available on the Union market as of the date of signature of this document meets the standards of the following applicable Union harmonisation legislation:

nous déclarons, sous notre seule responsabilité, à la date de la présente signature, la conformité du produit pour le marché de l'Union, aux directives d'harmonisation de la législation au sein de l'Union:

- 2014/30/EU
- 2011/65/EU

Bei der Bewertung wurden folgende einschlägige harmonisierte Normen zugrunde gelegt bzw. wird die Konformität erklärt in Bezug die nachfolgend genannten anderen technischen Spezifikationen:

The evaluation assessed the following applicable harmonised standards or the conformity is declared in relation to other technical specifications listed below:

L'évaluation est effectuée à partir des normes harmonisées applicable ou la conformité est déclarée en relation aux autres spécifications techniques désignées ci-dessous:

- EN 61326-1:2013

Diese Erklärung wird verantwortlich für den Hersteller:

This declaration is submitted on behalf of the manufacturer:

Le fabricant assume la responsabilité de cette déclaration:

NIVUS GmbH
Im Täle 2
75031 Eppingen
Allemagne

abgegeben durch / *represented by / faite par:*

Marcus Fischer (Geschäftsführer / *Managing Director / Directeur général*)

Eppingen, den 20.04.2016

Gez. *Marcus Fischer*

UK Declaration of Conformity

NIVUS GmbH
Im Tale 2
75031 Eppingen

Telefon: +49 07262 9191-0
Telefax: +49 07262 9191-999
E-Mail: info@nivus.com
Internet: www.nivus.de

For the following product:

Description:	Ultrasonic active sensors POA / OCL / CS2
Type:	POA-... / OCL-... / CS2-...

we declare under our sole responsibility that the equipment made available on the UK market as of the date of signature of this document meets the standards of the following applicable UK harmonisation legislation:

- SI 2016 / 1091 The Electromagnetic Compatibility Regulations 2016
- SI 2012 / 3032 The Restriction of the Use of Certain Hazardous Substances in Electrical and Electronic Equipment Regulations 2012

The evaluation assessed the following applicable harmonised standards or the conformity is declared in relation to other technical specifications listed below:

- BS EN 61326-1:2013

This declaration is submitted on behalf of the manufacturer:

NIVUS GmbH
Im Taele 2
75031 Eppingen
Germany

represented by:

Ingrid Steppe (Managing Director)

Eppingen, 21/10/2022

Signed by *Ingrid Steppe*

EU Konformitätserklärung

EU Declaration of Conformity

Déclaration de conformité UE

NIVUS GmbH
Im Täle 2
75031 Eppingen

Telefon: +49 07262 9191-0
Telefax: +49 07262 9191-999
E-Mail: info@nivus.com
Internet: www.nivus.de

Für das folgend bezeichnete Erzeugnis:

For the following product:

Le produit désigné ci-dessous:

Bezeichnung:	"Ex" Ultraschall-Aktivsensoren POA / OCL / CS2
<i>Description:</i>	<i>"Ex" Ultrasonic active sensors</i>
<i>Désignation:</i>	<i>"Ex" capteurs actifs ultrasoniques</i>
Typ / Type:	POA-x2xxxxE... / OCL-L1xxxxE... / CS2-xxxxxxE...

erklären wir in alleiniger Verantwortung, dass die auf dem Unionsmarkt ab dem Zeitpunkt der Unterzeichnung bereitgestellten Geräte die folgenden einschlägigen Harmonisierungsvorschriften der Union erfüllen:

we declare under our sole responsibility that the equipment made available on the Union market as of the date of signature of this document meets the standards of the following applicable Union harmonisation legislation:

nous déclarons, sous notre seule responsabilité, à la date de la présente signature, la conformité du produit pour le marché de l'Union, aux directives d'harmonisation de la législation au sein de l'Union:

- 2014/30/EU
- 2014/34/EU
- 2011/65/EU

Bei der Bewertung wurden folgende einschlägige harmonisierte Normen zugrunde gelegt bzw. wird die Konformität erklärt in Bezug die nachfolgend genannten anderen technischen Spezifikationen:

The evaluation assessed the following applicable harmonised standards or the conformity is declared in relation to other technical specifications listed below:

L'évaluation est effectuée à partir des normes harmonisées applicable ou la conformité est déclarée en relation aux autres spécifications techniques désignées ci-dessous:

- EN 61326-1:2013
- EN IEC 60079-0:2018
- EN 60079-11:2012

Ex-Kennzeichnung / *Ex-designation* / *Marquage Ex* :

 II 2G Ex ib IIB T4 Gb

EU-Baumusterprüfbescheinigung / *EU-Type Examination Certificate* / *Attestation d'examen «UE» de type:*

TÜV 03 ATEX 2262 (4. Ergänzung)

Notifizierte Stelle (Kennnummer) / *Notified Body (Identif. No.)* / *Organisme notifié (Nº d'identification)*

TÜV Nord CERT GmbH, Am TÜV 1, 45307 Essen, Germany

(0044)

Diese Erklärung wird verantwortlich für den Hersteller:

This declaration is submitted on behalf of the manufacturer:

Le fabricant assume la responsabilité de cette déclaration:

NIVUS GmbH
Im Taele 2
75031 Eppingen
Allemagne

abgegeben durch / *represented by* / *faite par:*

Marcus Fischer (Geschäftsführer / *Managing Director* / *Directeur général*)

Eppingen, den 18.02.2022

Gez. *Marcus Fischer*

UK Declaration of Conformity

NIVUS GmbH
Im Tale 2
75031 Eppingen

Telefon: +49 07262 9191-0
Telefax: +49 07262 9191-999
E-Mail: info@nivus.com
Internet: www.nivus.de

For the following product:

Description: "Ex" Ultrasonic active sensors POA / OCL / CS2

Type: POA-x2xxxxE... / OCL-L1xxxxE... / CS2-xxxxxxE...

we declare under our sole responsibility that the equipment made available on the UK market as of the date of signature of this document meets the standards of the following applicable UK harmonisation legislation:

- SI 2016 / 1091 The Electromagnetic Compatibility Regulations 2016
- SI 2016 / 1107 The Equipment and Protective Systems Intended for use in Potentially Explosive Atmospheres Regulations 2016
- SI 2012 / 3032 The Restriction of the Use of Certain Hazardous Substances in Electrical and Electronic Equipment Regulations 2012

The evaluation assessed the following applicable harmonised standards or the conformity is declared in relation to other technical specifications listed below:

- BS EN 61326-1:2013
- BS EN IEC 60079-0:2018
- BS EN 60079-11:2012

Ex-designation:



II 2G Ex ib IIB T4 Gb

EU-Type Examination Certificate:

TÜV 03 ATEX 2262 (4. Supplement)

Notified Body (Identif. No.):

TÜV Nord CERT GmbH, Am TÜV 1, 45307 Essen, Germany

(0044)

This declaration is submitted on behalf of the manufacturer:

NIVUS GmbH
Im Tale 2
75031 Eppingen
Germany

represented by:

Ingrid Steppe (Managing Director)

Eppingen, 21/10/2022

Signed by *Ingrid Steppe*